

# BA32R

## BILL ACCEPTOR

### Operation and Service Manual



 **coinco**®

# TABLE OF CONTENTS

## SECTION 1: GENERAL INFORMATION

Introduction .....	3
Models .....	3
For Your Records .....	3
Features .....	3
After Unpacking .....	3
Main Logic Board Assembly .....	3
Specifications .....	4
Dimensional Drawing .....	4

## SECTION 2: INSTALLATION

Option Switch Settings .....	5
Installing the Bill Acceptor .....	5

## SECTION 3: OPERATION

Bill Recognition .....	6
Bill Validation .....	6
Bill Stacking and Credit .....	6
Bill Rejection .....	6
Component Explanation	
Bill Transport and Stacking .....	6
Left and Right Alignment Sensors .....	6
Center Optic Sensor .....	6
Left and Right Optic Sensor .....	6
Magnetic Sensor .....	6
Anti-Pullback Levers .....	6
Stacker Home Sensor .....	6
Encoder Sensor .....	6
Bill Box Switch .....	6
Component Explanation Drawing .....	7
Interconnect Drawing .....	8

## SECTION 4: MAINTENANCE

Disassembling the BA32R .....	9
Disassembling the Lower Housing .....	10
Disassembling the Chassis .....	13
Routine Cleaning Procedure .....	15
Cleaning Procedure for Salted Units .....	16

## SECTION 5: TROUBLESHOOTING

Introduction .....	17
Diagnostic Flash Codes .....	17
Troubleshooting Guide .....	18

## SECTION 6: PARTS LIST

Main Frame .....	23
Chassis Assembly .....	24
Lower Housing Assembly .....	25
Intermediate Frame Assembly .....	26
Cashbox Assembly .....	26

# SECTION 1: GENERAL INFORMATION

## INTRODUCTION

This manual contains information on installing, operating and maintaining Coinco's BA32R bill acceptor. This manual is intended for owners, route operators and shop-level technicians as a primary source of information. Taking time to read this manual and becoming familiar with this information will help you obtain the best performance from your Coinco bill acceptor.

## MODELS

The BA32R bill acceptor is a self-contained bill acceptor designed to interface with existing vending machines.

## FOR YOUR RECORDS

A label indicating the bill acceptor model number and serial number is affixed to the back of the bill acceptor. Refer to the model and serial number whenever you call upon your Coinco Service Center for information or service. The first four digits of the serial number contain the manufacturing date code which indicates the beginning of the warranty period.

*EXAMPLE: Serial No. 269107053. First and second digits indicate week of manufacture. Third and fourth digits indicate year of manufacture.*

## FEATURES

- Modular design.
- State-of-the-art electronic logic system.
- Programmable to accept any combination of the following bills: \$1, \$2, \$5, \$10, \$20.
- Fast, accurate acceptance of both new and heavily circulated bills.
- High capacity bill box.
- Vandal-resistant design protects against:
  - Saltwater
  - Bill Pullback
  - Counterfeit Bills
- Utilizes low level pulse, serial, parallel, and Multi-Drop Bus electrical interfaces.
- Utilizes standard mounting and electrical interfaces.
- 24VAC and 24VDC Multi-Drop Bus interfaces.

- High impact, noncorrosive plastic construction.
- Easily accessible bill path.
- Self-diagnostics communicated via status light.
- Standard/high level security switch.
- Accepts bills face up in one or both directions.
- Manufactured and supported by Coinco.
- Made in the U.S.A.

## AFTER UNPACKING

After unpacking the unit, inspect it for any possible shipping damage. If the unit is damaged, notify the shipping company immediately. Only the consignee (the person or company receiving the unit) can file a claim against the carrier for shipping damage. We recommend that you retain the original carton and packing materials to reuse if you need to transport or ship your acceptor in the future.

If the bill acceptor is being stored or used as a spare, always keep it in its shipping carton when not in use. This will keep it clean and offer the best protection for the unit.

## MAIN LOGIC BOARD ASSEMBLY

The main logic board contains the microprocessor which controls all the functions of the bill acceptor based on information from the vending machine and various bill acceptor sensors.

Also contained on the main logic board is the power supply which receives its primary voltage from the vending machine. On 24VAC and 24VDC interfaces, the primary voltage is rectified, reduced to 12 volts, and filtered on the logic board.

# SECTION 1: GENERAL INFORMATION

## SPECIFICATIONS

### Power Requirements

#### 24VAC

20 to 32VAC rms 60 Hz

0.2 Amp avg. standby

2.5 Amp avg. operating

#### 24VDC (MDB)

22 to 45VDC

0.2 Amp avg. standby

2.5 Amp avg. operating

### Operating Temperature

0° F to 150° F

-18° C to 65° C

### Storage Temperature

-22° F to 165° F

-30° C to 74° C

### Relative Humidity

5% to 95% Non-condensing

### Physical Weight in Shipping Carton

4 pounds

### Physical Dimensions

Height: 11.75 inches (top of bill box to bottom of mounting plate)

Width: 3.69 inches

Depth: 5.04 inches (mounting plate to back of stacker)

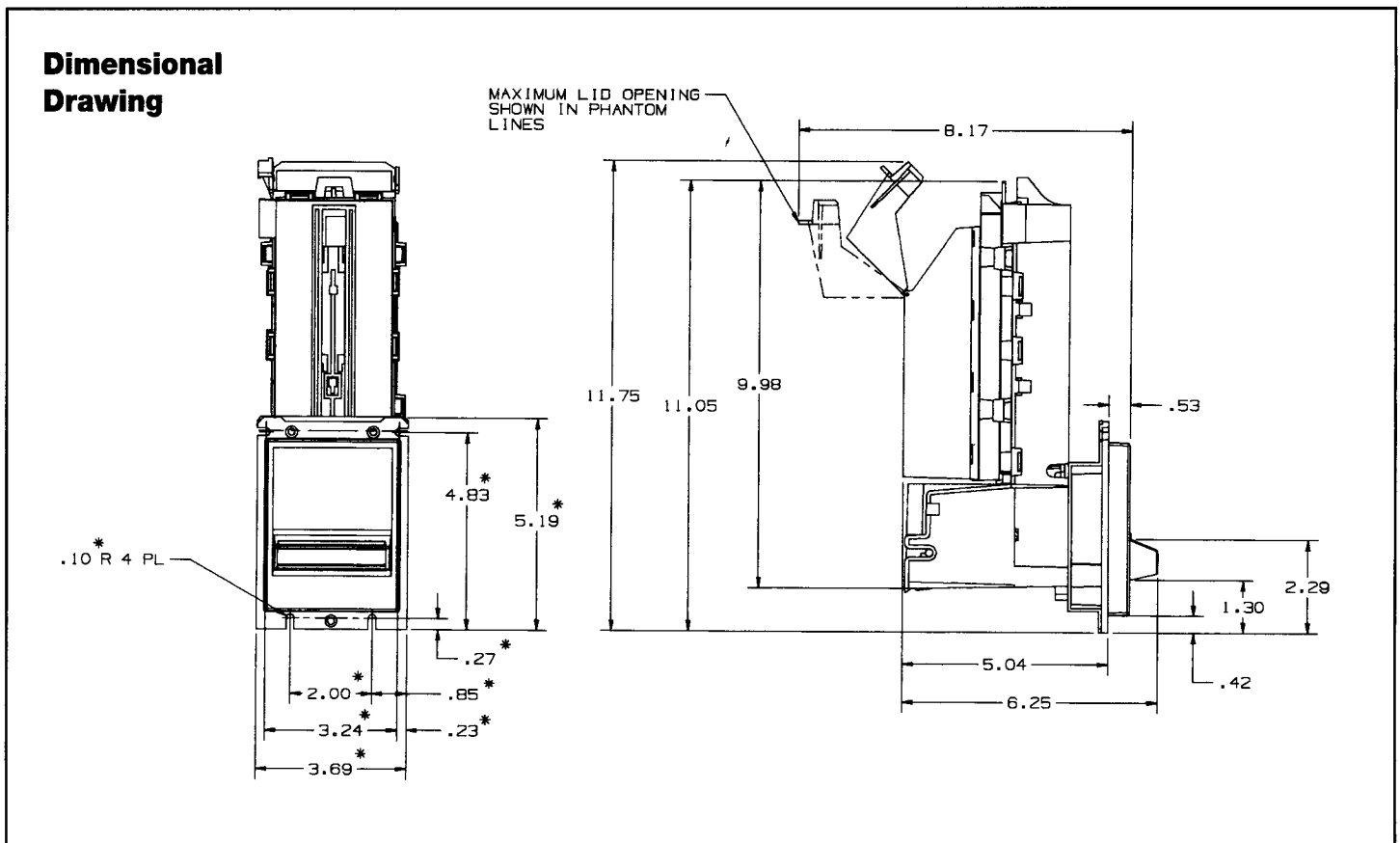

# SECTION 2: INSTALLATION

## OPTION SWITCH SETTINGS

The BA32R bill acceptor contains an option switch module allowing the unit to be customized to the requirements of the individual account. This switch module is factory set with switches 3 and 8 in the ON position and positions 1, 2, 4, 5, 6 and 7 in the OFF position.

### Setting The Option Switches (see Figure 1)

Remove power from the bill acceptor. Remove the lower housing from the main frame to access the option switches (see Figure 1). Set the option switches to the desired positions (see Figure 2). Slide the lower housing into the main frame, apply power and test for proper operation.

### BA32R Option Switch Settings (see Figure 2)

Switch	On	Off
1	High Security	Standard Acceptance
2	Accepts bills in one direction only (face up, green seal first)	Accepts bills in both directions (face up)
3	Serial/Parallel Interface	Pulse Interface
4	\$20 Accept	\$20 Reject
5	\$10 Accept	\$10 Reject
6	\$5 Accept	\$5 Reject
7	\$2 Accept	\$2 Reject
8	\$1 Accept	\$1 Reject

## INSTALLING THE BILL ACCEPTOR

1. Remove power from the vending machine.
2. Set the option switches to the desired settings.
3. Mount the bill acceptor according to mounting instructions found in vending machine manual or appropriate kit literature.
4. Connect the bill acceptor's harness connectors to the vendor's mating connectors.
5. Load the vending machine with product and the coin mechanism with change.
6. Apply power to the vending machine.
7. Test bill acceptor for proper operation.

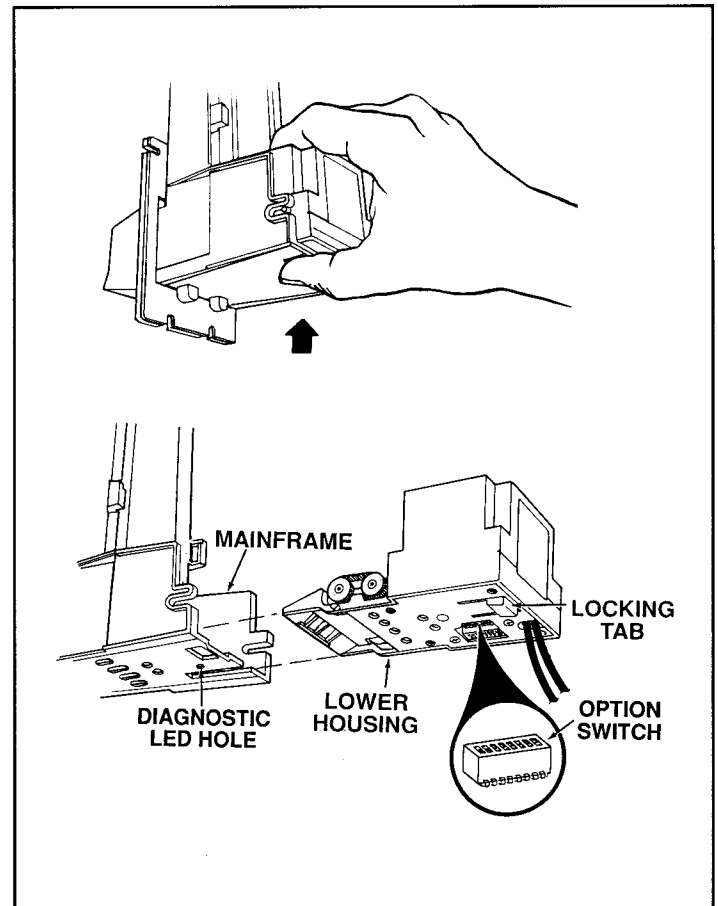

Figure 1

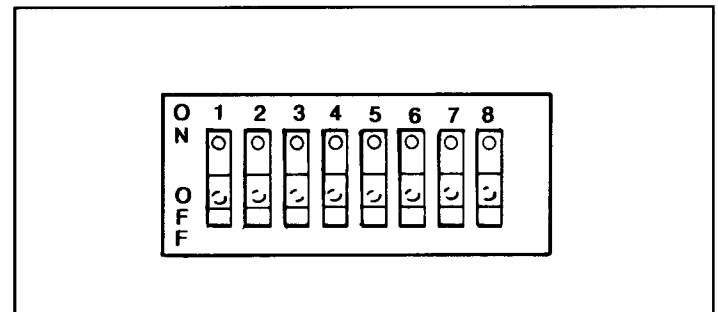

Figure 2

## SECTION 3: OPERATION

### BILL RECOGNITION

When a bill is inserted into the bill acceptor and it blocks the left and right alignment sensors as well as the center optic sensor, the transport motor begins to run.

### BILL VALIDATION

From the time the transport motor begins to run until the trailing edge of the bill leaves the alignment sensors, optical and magnetic sensors send information to the microprocessor to determine the validity of the bill.

### BILL STACKING AND CREDIT

If the bill is determined to be authentic, it is transported to the stack position. Once the sensors of the lower track's anti-pullback lever signals the microprocessor that the bill is in the stacking position, the stacker motor runs and credit is given.

### BILL REJECTION

If the bill is determined to be invalid, the wrong denomination or the anti-pullback levers are active when the bill is determined to be in the stack position, the transport motor will reverse returning the bill to the customer.

### COMPONENT EXPLANATION (SEE FIGURE 3)

#### Bill Transport and Stacking

The bill transport system is composed of a motor and gearcase assembly and three sets of pulleys and belts: the lower housing belts, the chassis belts and the intermediate frame belts. When the transport motor is energized, it pulls the bill in by sandwiching it between the lower housing belts and the chassis belts. During the validation process, the bill is transferred from the lower housing and chassis belts to the intermediate frame and chassis belts.

The bill stacker is composed of a motor and gearcase assembly and a pusher plate assembly. When the bill is transported past the anti-pullback levers into the stacking position, the stacker motor energizes driving the pusher plate, which in turn, pushes the bill into the bill box.

#### Left and Right Alignment Sensors

The left and right alignment sensors send information to the microprocessor to insure that the bill is the right width and that it is being fed in correctly.

#### Center Optic Sensor

The center optic sensor informs the microprocessor that the bill is ready to be transported if the information from the alignment sensors is correct.

#### Left and Right Optic Sensors

The left and right optic sensors and associated circuitry perform various optical checks on the bill and send that information to the microprocessor for bill validation.

#### Magnetic Sensor

The magnetic sensor and its associated circuitry performs checks on the magnetic properties of the bill and sends that information to the microprocessor for bill validation.

#### Anti-Pullback Lever

The lower anti-pullback lever is optically monitored to tell the microprocessor when the bill has entered the stack position or if an attempt to defraud the unit is taking place.

#### Stacker Home Sensor

The stacker home sensor is an optical sensor that informs the microprocessor of the position of the stacker pusher plate.

#### Encoder Sensor

Connected to the transport motor is an encoder wheel which is optically monitored to determine the speed of the transport motor and to determine the position of the bill in the bill path.

#### Bill Box Switch

The bill box switch (if equipped) resets the bill acceptor each time the lid is closed. For units without a bill box switch, reset is controlled by the microprocessor.

# SECTION 3: OPERATION

## Component Explanation

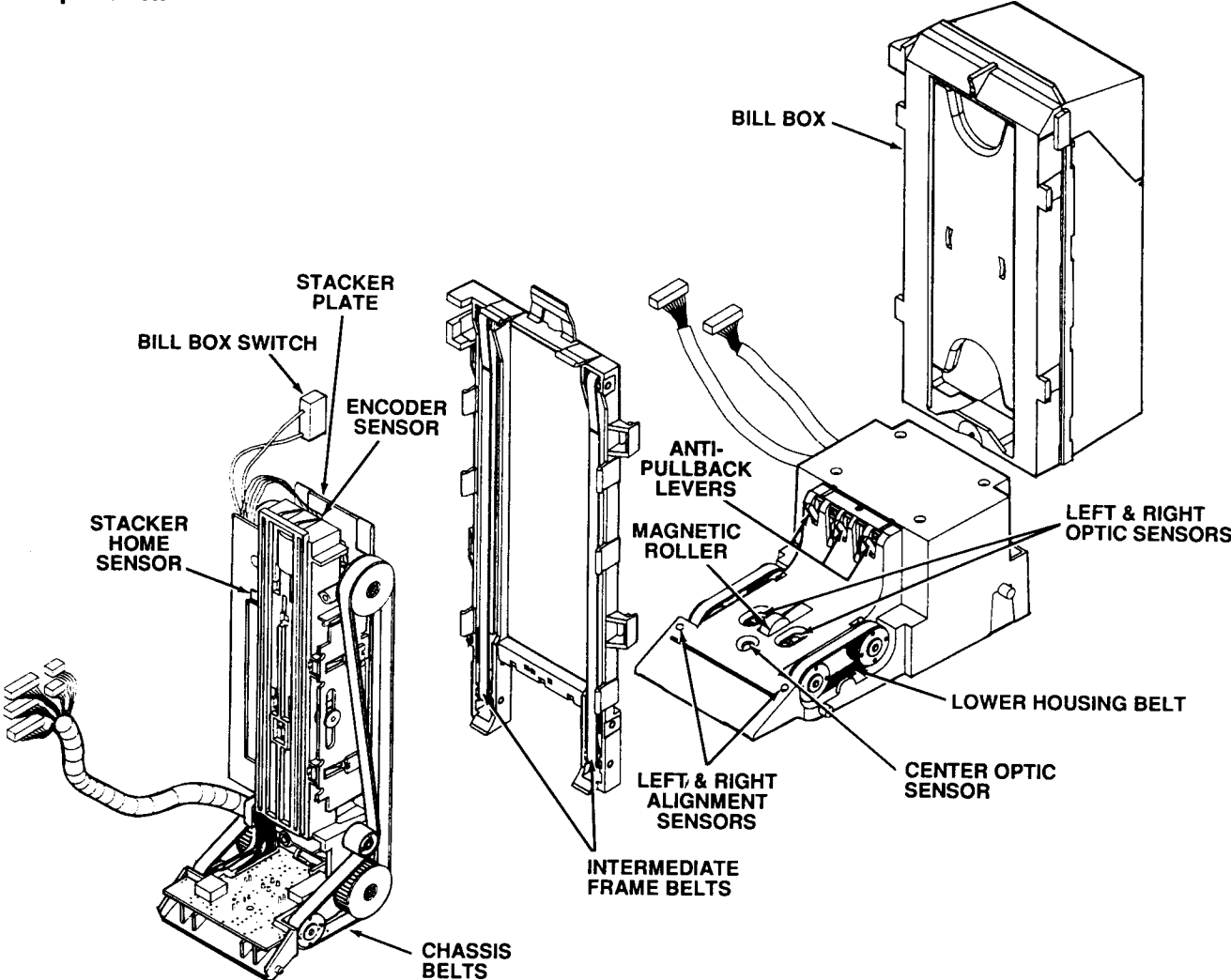
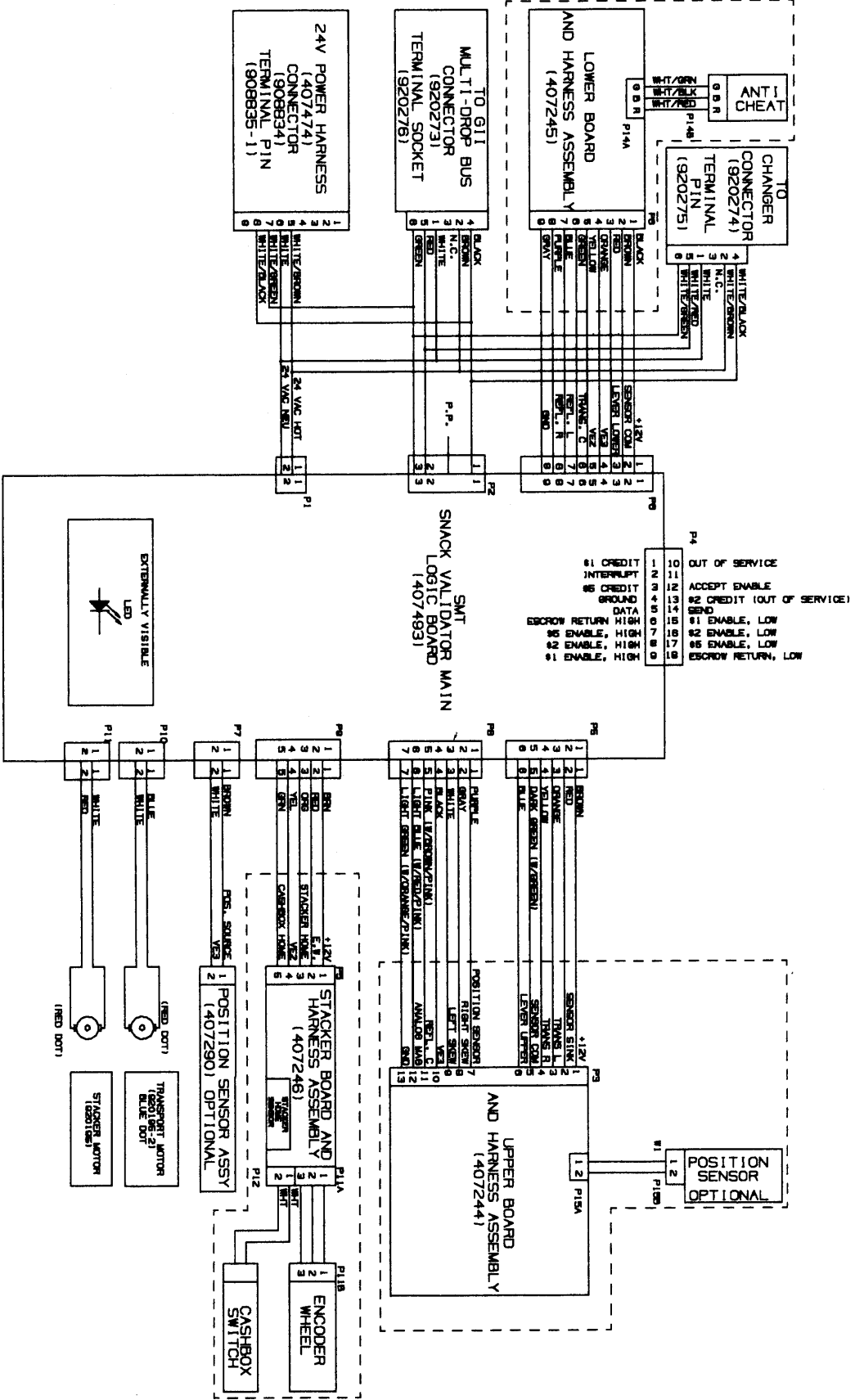

Figure 3

# SECTION 3: OPERATION

Interconnect Drawing





## SECTION 4: MAINTENANCE

### DISASSEMBLING THE BA32R

#### Removing the Bill Box (see Figure 4)

Push the bill box tab forward while sliding the bill box up.

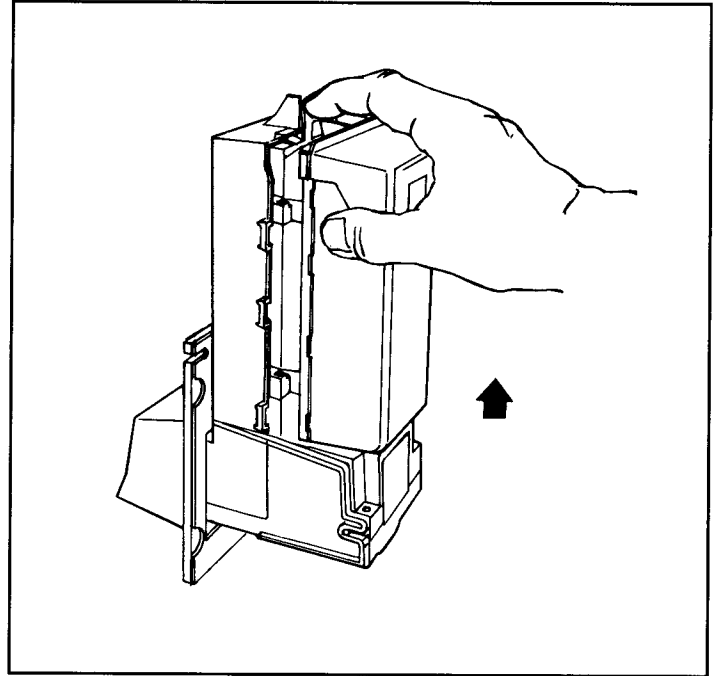

Figure 4

#### Removing the Lower Housing (see Figure 5)

To remove the lower housing, push the locking tab on the bottom of the bill acceptor and pull the lower housing to the rear.

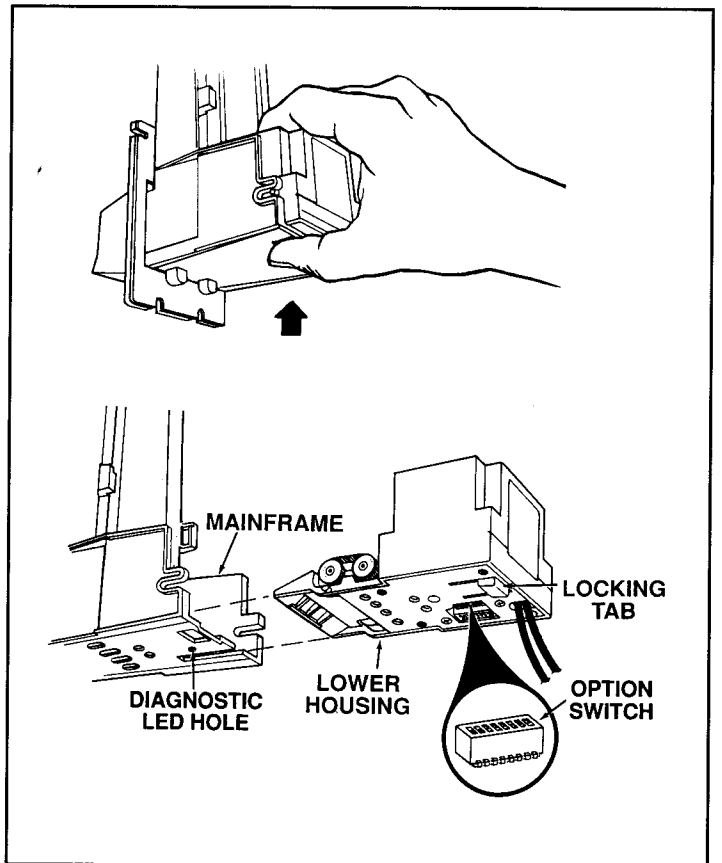

Figure 5

# SECTION 4: MAINTENANCE

## DISASSEMBLING THE LOWER HOUSING

### Removing the Main Logic Board (see Figure 6)

Remove the lower housing from the main housing. Remove the four Phillips screws that secure the cover to the lower housing and logic board. Raise the lower housing cover and unplug the harnesses from the logic board.

*NOTE: Cover may be attached to water shield with silicon sealant.*

*NOTE: The logic boards are connected to the lower housing cover. Carefully remove the cover and logic boards from the lower housing.*

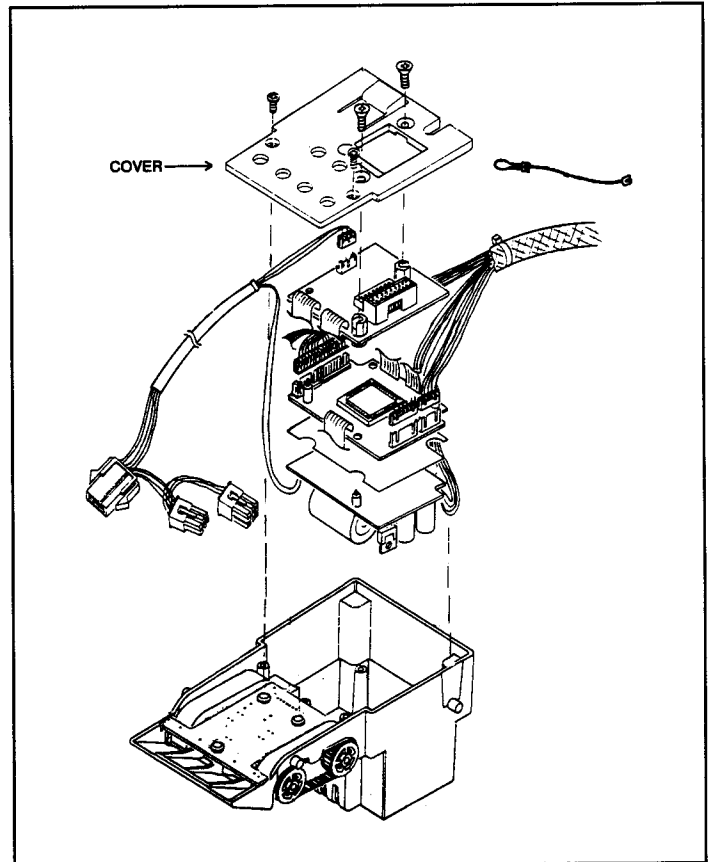

Figure 6

### Removing the Lower Sensor Board (see Figure 7)

Remove the water shield from the lower housing by pulling outward from the lower housing. Remove the Phillips screw that secures the sensor board to the lower housing, unsnap the lower housing anti-pullback sensor board and remove the sensor board.

### Removing the Mag Roller and Spring (see Figure 7)

Remove the two Phillips screws that secure the mag roller spring and remove the spring and roller.

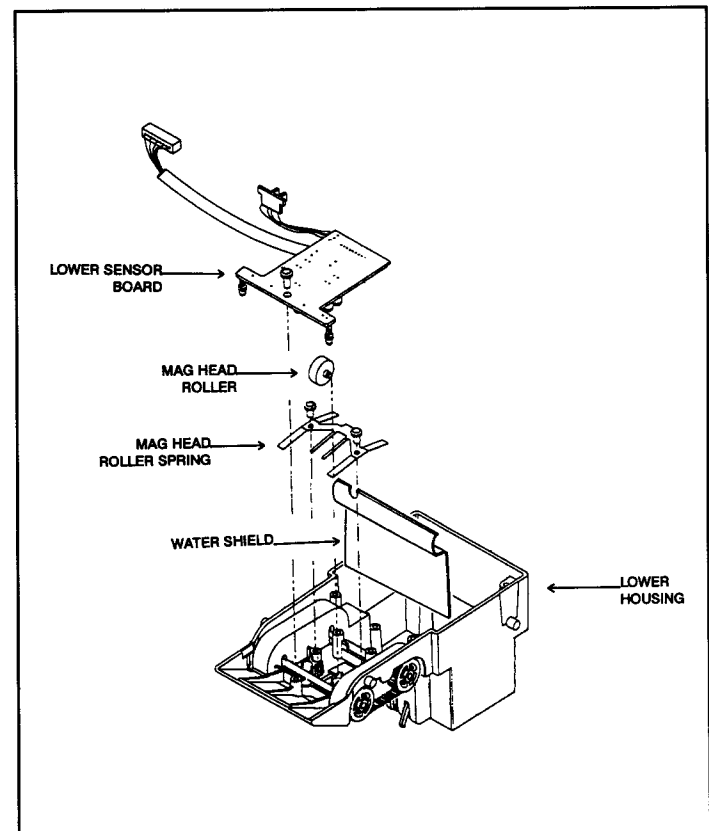

Figure 7

## SECTION 4: MAINTENANCE

### Removing the Lower Housing Anti-Pullback Lever and Spring (see Figure 8)

Using a small drift or Phillips screwdriver, depress the locking tab in small hole in top of lower housing frame. At the same time, insert a small standard blade screwdriver into center slot and push anti-pullback assembly back out of retaining tabs. Remove anti-pullback lever from base by releasing one locking tab on base. Pay close attention to positioning of spring to assure its correct position on reassembly.

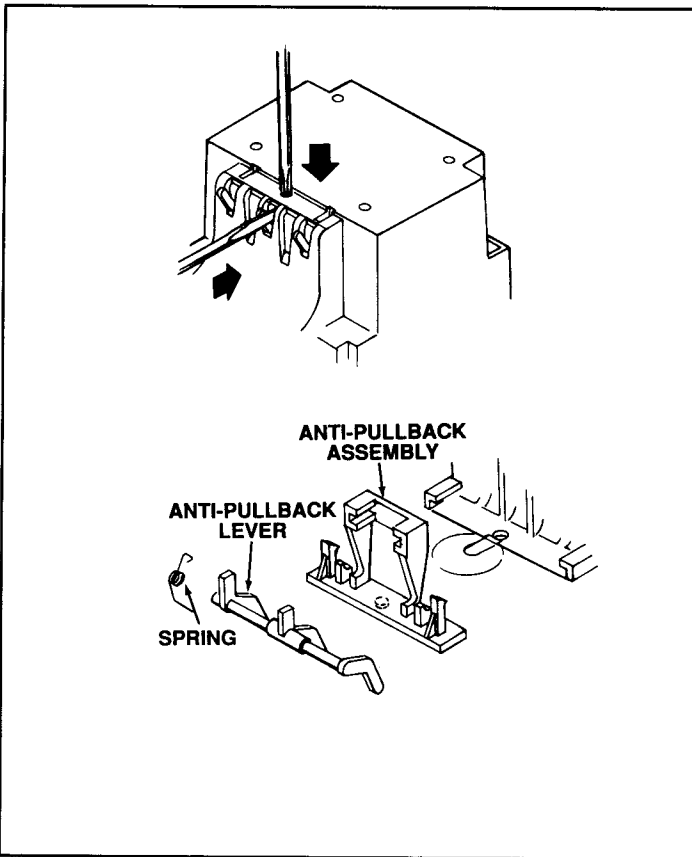

Figure 8

### Removing the Lower Housing Belts and Pulleys (see Figure 9)

Slide either the front or back pulley off its shaft to free the belt and remove the belt.

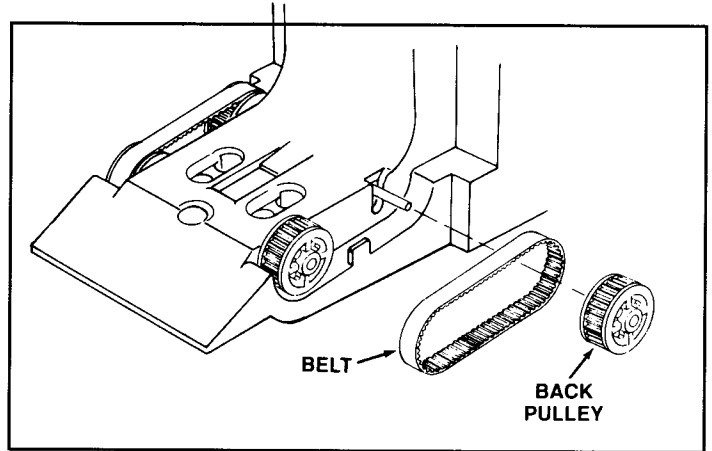

Figure 9

### Removing the Intermediate Frame (see Figure 10)

Using a small straight tip screwdriver, free the ten locking tabs which secure the intermediate frame to the main frame and remove the intermediate frame.

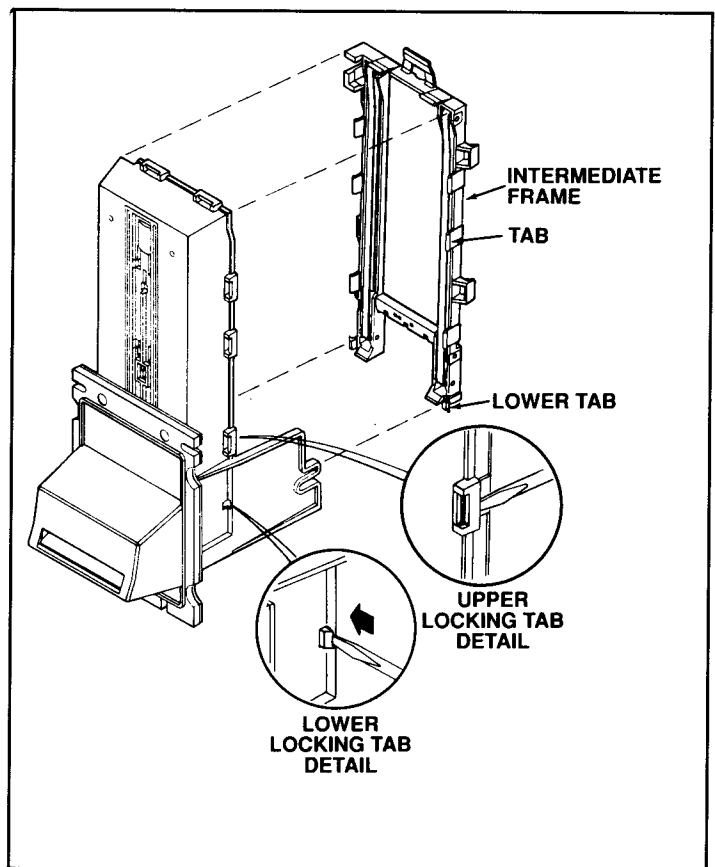

Figure 10

## SECTION 4: MAINTENANCE

### Removing the Inlet Mask (see Figure 11)

Using a Phillips screwdriver and a 5/16" wrench, remove the three screws and nuts from the inlet mask and remove the mask.

### Removing the Mounting Frame and Static Grounding Spring (see Figure 11)

Using a Phillips screwdriver, remove the screws that secure the mounting plate and grounding spring and remove both.

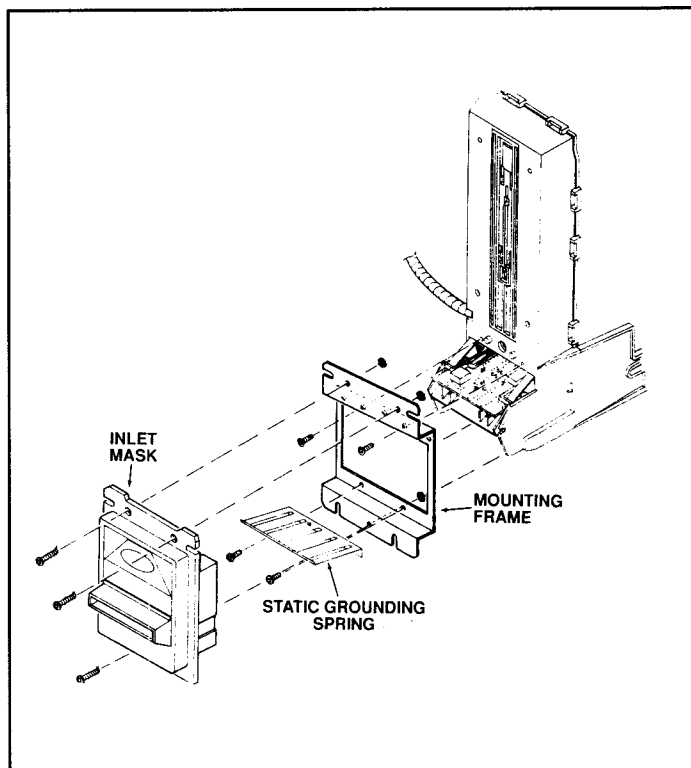

Figure 11

### Removing the Chassis from the Mainframe (see Figure 12)

Free the bill box switch (if equipped) from the main frame by sliding it toward the bill box area until it clears the main frame. Let the switch hang. Remove the expando tubing from the chassis harness. Spread the main frame to free the two locating pins of the chassis from the main frame and pull down on the chassis. Carefully route the chassis harness through the opening in the main frame. Pull the chassis through the lower main frame opening.

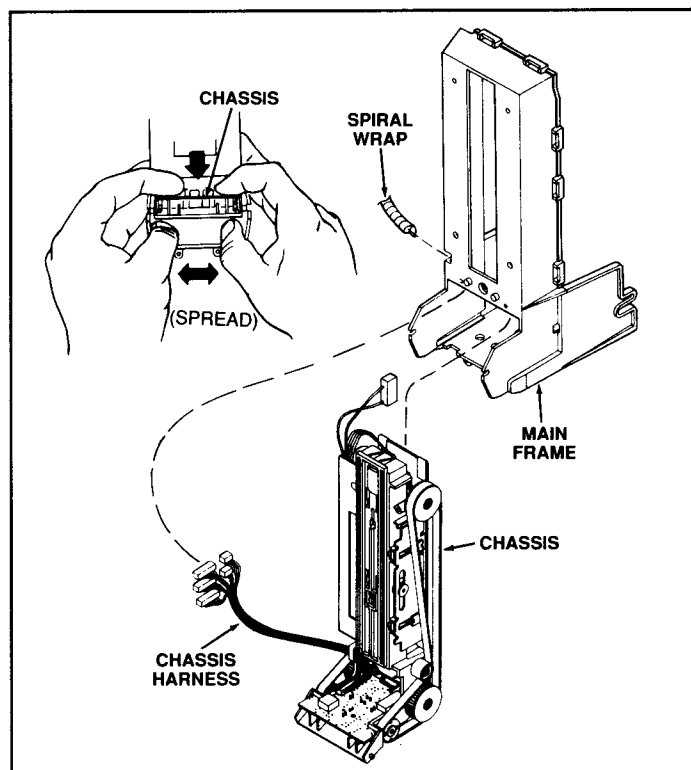

Figure 12

## DISASSEMBLING THE CHASSIS

### Removing the Pusher Plate from the Chassis (see Figure 13)

Cut the ty-rap that secures the chassis harnessing. Remove the two T15 Torx head shoulder screws that secure the pusher plate to the stacker gear box assembly. Pull the pusher plate straight out until the locking tabs of the pusher plate slides catch the chassis frame. Using a small screwdriver, release the four tabs and remove the pusher plate.

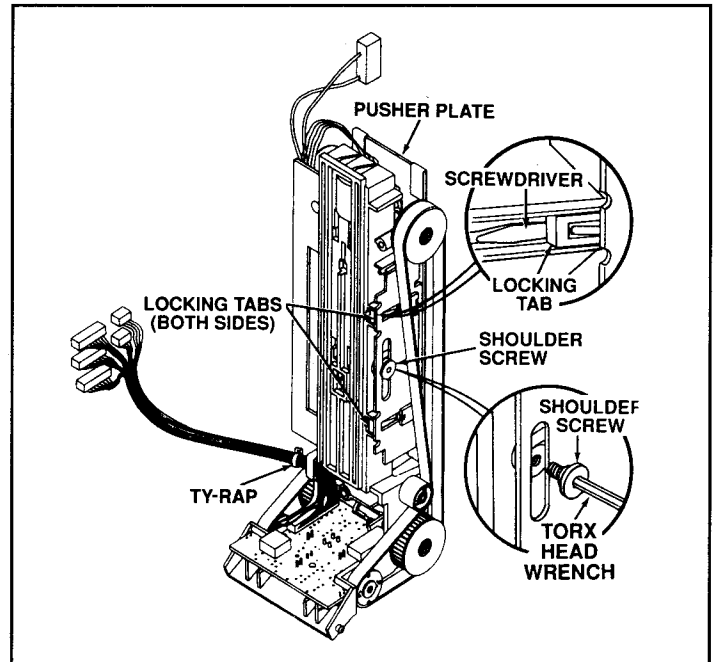

Figure 13

### Removing the Encoder Sensor and Stacker Logic Board (see Figure 14)

Free the encoder sensor from the top of the inlet motor gear case assembly. Remove the Phillips screw that secures the stacker board to the chassis frame and remove the stacker board.

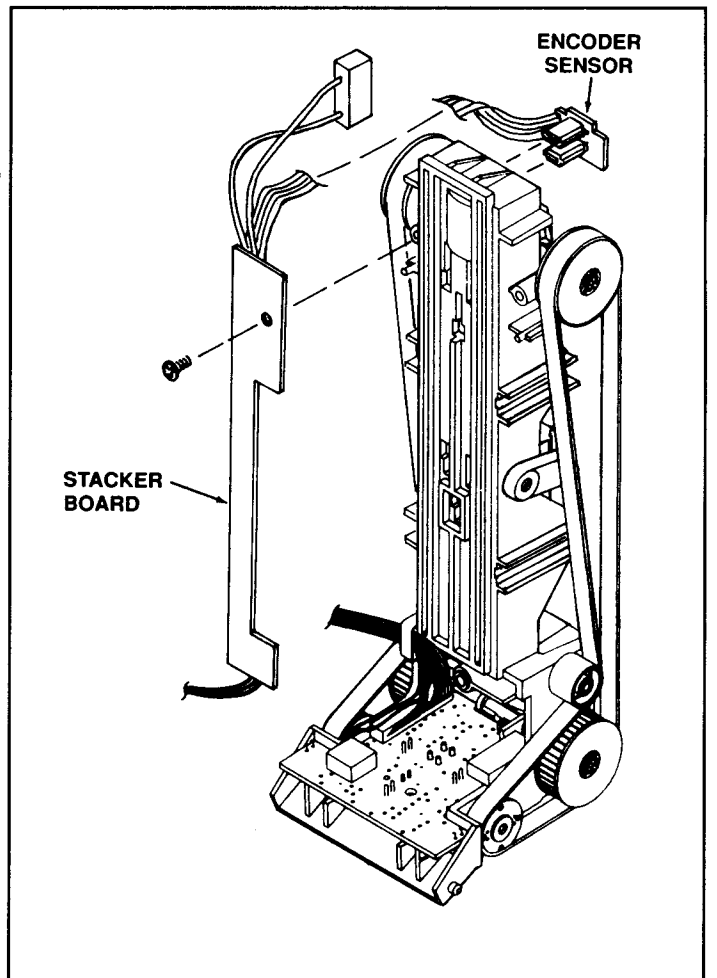

Figure 14

# SECTION 4: MAINTENANCE

## Removing the Chassis Belts and Pulleys (see Figure 15)

Compress the belt tensioning spring by pressing down on the inlet motor and gear case assembly and remove the chassis belts. Slide the pulleys off the lower shafts to prevent them from falling off.

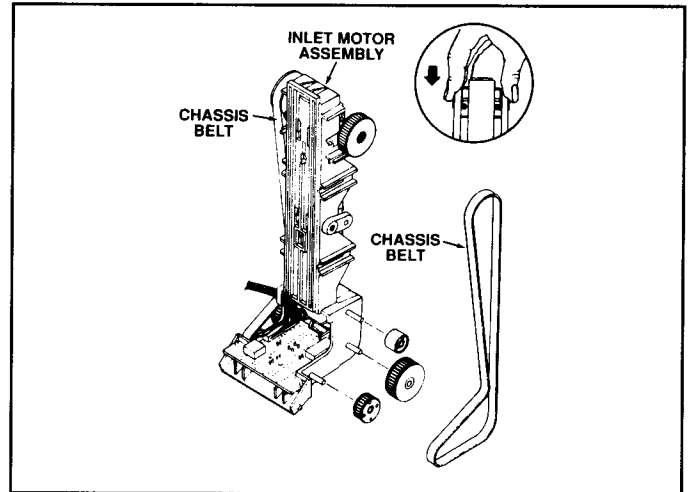

Figure 15

## Removing the Inlet and Stacker Gear Box and Motor Assemblies (see Figure 16)

Compress the belt tensioning spring by pushing up on the stacker motor and gear case assembly until the three locking tabs of the gear case can be freed from their mating slots in the chassis frame. Remove the motor and gear case assembly and the tension springs. Slide the inlet motor and gear case assembly down until its three locking tabs are freed from their mating slots in the chassis frame.

**NOTE:** It may be necessary to remove the chassis belt pulleys from the motor and gear case assembly.

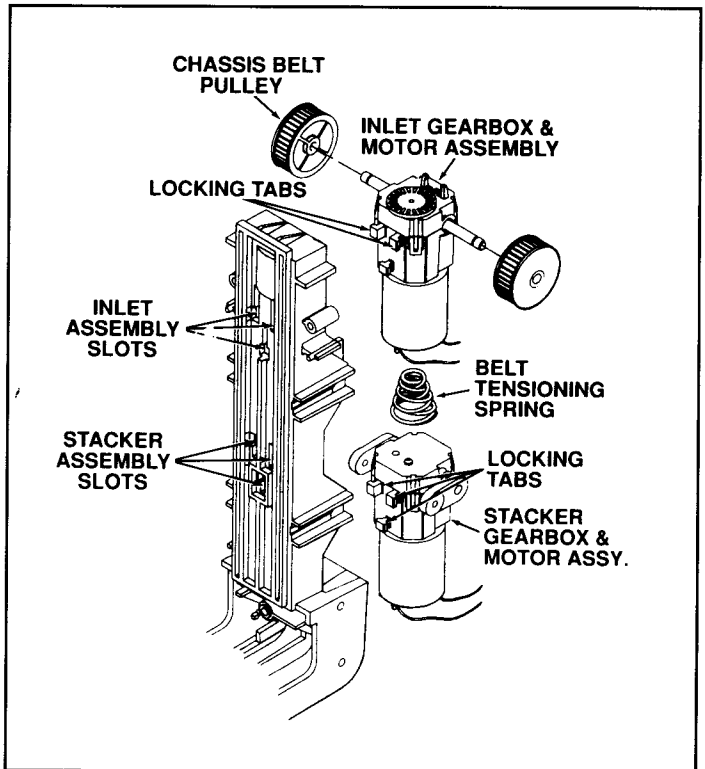

Figure 16

## Removing the Upper Sensor Board from the Chassis (see Figure 17)

Remove the lower chassis belt shaft. Using a small screwdriver, remove the two metal sensor board retaining clips and the harness retaining clip. Lift the front of the sensor board and pull forward.

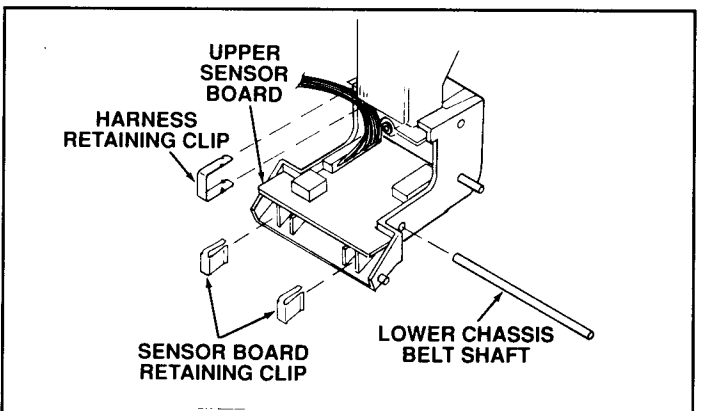

Figure 17

## SECTION 4: MAINTENANCE

### Removing the Chassis Anti-Pullback Lever and Spring (see Figure 18)

Remove the center chassis belt shaft and remove the anti-pullback lever and spring.

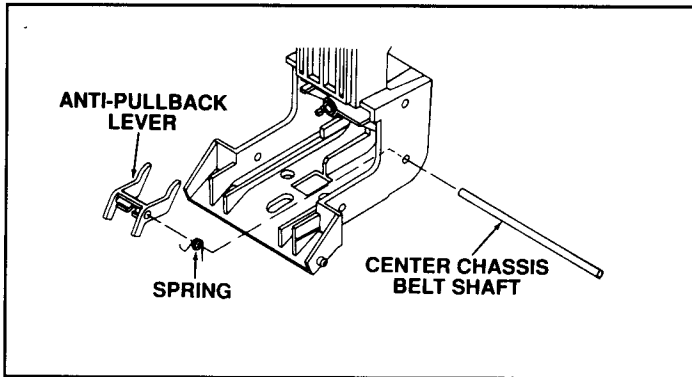

Figure 18

### ROUTINE CLEANING PROCEDURE

*NOTE: Petroleum-based cleaners and freon-based propellants can damage plastic and some electronic components. Scouring pads and stiff brushes may harm the protective conformal coating on the circuit boards and can mar the plastic. These items should never be used when cleaning the BA32R bill acceptor.*

The BA32R should be cleaned every 20,000 bills or every two years (or as needed, depending on the environmental conditions of the location). Dust can be removed with a soft brush or cloth or it can be blown out using compressed air.

1. Disconnect power from the bill acceptor.
2. Remove the bill box and use a soft cloth to wipe the dust from around the intermediate frame and stacker plate.
3. Remove the lower housing.
4. Using compressed air or a soft brush, blow or brush the dust off of the optic sensors and out of the recessed sensor openings.
5. Remove dust from around the belts and wheels on the lower housing and the sensors on the upper sensor board. The upper sensors are located directly above the lower housings sensor when the lower housing is installed.
6. The bill path can be cleaned to remove further dirt using a soft cloth moistened with a mild soap and water solution
7. Clean the magnetic head using a swab and isopropyl alcohol.
8. Once the lower housing is dry, place it back into the mainframe so that the tab on the bottom locks into place.
9. Blow the dust out of the encoder wheel and its sensors. (It may be necessary to extend the stacker plate to access the encoder wheel. This can be done by supplying power to the unit momentarily, so that the stacker plate extends.)
10. Remove dust from the transport belt areas and from any other places of build up.
11. Remount the bill box.
12. Apply power and insert bills to verify that the unit is functioning properly.

## SECTION 4: MAINTENANCE

### CLEANING PROCEDURE FOR SALTED UNITS

***NOTE:** Petroleum-based cleaners and freon-based propellants can damage plastic and some electronic components. Scouring pads and stiff brushes may harm the protective conformal coating on the circuit boards and can mar the plastic. These items should never be used when cleaning the BA32R bill acceptor.*

1. Remove power from the bill acceptor.
2. Remove the bill acceptor from the vending machine.
3. Open the bill box lid and verify that the stacker plate is in the standby/home position. If it is not in the home position, apply power and observe that the stacker plate returns home.

***WARNING:** If moisture is present, allow the unit to dry thoroughly before applying power to avoid possible shock hazard. If the stacker plate does not return to the home position, remove power and carefully remove the bill box to avoid damaging the bill box and/or stacker plate.*

4. Remove the lower housing.
5. Remove the bottom cover and logic boards from the lower housing.
6. Run hot water (110°-140°F) over the lower housing from the top and bottom. Using a soft brush, gently clean any residual salt. Use a soft absorbent cloth to clean any residue off the lower housing.

***CAUTION:** The motor and main logic boards are not protected from moisture. Therefore the unit must be held in a manner that prevents water from running onto the logic boards or into the motor area.*

7. Remove the front mask. Using hot water and a soft brush, clean the front mask, upper sensor board, main frame anti-pullback levers.
8. Verify that the anti-pullback levers move freely and that the spring returns them to their open position.
9. Allow the unit to dry thoroughly.
10. Clean the magnetic head using a swab and isopropyl alcohol.
11. Replace the front mask.
12. Replace the lower housing cover.
13. Replace the lower housing into the main frame.
14. Remount the bill box.
15. Apply power and insert bills to verify that the unit is functioning properly.



## INTRODUCTION

The Troubleshooting Guide on the following pages is intended to help locate problems within the bill acceptor. If an acceptor cannot be repaired by following the guide, return the acceptor to the nearest Coinco Service Center for repair. If it is necessary to return the acceptor to Coinco, please accompany the acceptor with a complete description of the malfunction to help expedite the repair and return of the bill acceptor.

Logic troubleshooting minimizes time spent in removing and replacing modules that are not defective. Some failures are caused by minor problems such as loose or faulty connections. Please check the following before replacing any parts:

- Connectors are inserted correctly.
- Connector pins are not bent or broken.
- All wires are properly secured.
- Coin changer inventory tubes are filled to their correct levels.

## DIAGNOSTIC FLASH CODES

Troubleshooting can be achieved by reading flashes or blinks of light from the Diagnostic LED (see Figure 19).

For BA32R's manufactured with a bill box switch, using CPU 921638-8: Diagnostic codes 1-5 may appear during normal servicing of the BA32R. To access diagnostic codes 6-18, open bill box lid and turn off power to the BA32R for 10 seconds. Reapply power to the BA32R with the bill box lid open. Diagnostic codes 6-18 will appear for the respective error conditions detected in the BA32R. If more than one error or condition exists, the lower number diagnostic code will appear until its condition is corrected.

For BA32R's manufactured without a bill box switch, using CPU 67044-4: Diagnostic codes 2, 8, 14 and 18 are not used. Codes 1, 3, 4, 5, 15 and 16 may appear during normal servicing. If the BA32R is flashing a 5 code, turn off power for 10 seconds. Reapply power and codes 6, 7, 9, 10, 11, 12, 13 and 17 will appear for approximately 30 seconds. After 30 seconds, these codes will revert back to the 5 code. If more than one error exists, the lower number code will appear until its condition is corrected.

# Of Flashes	Description of Codes
1	Bill Box Full
2	Not Used
3	Check Bill Path
4	All Bill Accept Switches Are Off
5	Bill Jam or Sensor Error
6	Stacker Motor/Home Sensor
7	Transport Motor/Encoder Sensor
8	(Reserved for Future Use)
9	EEPROM Check Sum Error
10	RAM or ROM Check Sum Error
11	Center Optic Sensor
12	Right Optic Sensor*
13	Left Optic Sensor*
14	Bill Position Sensor Error
15	Right position Sensor*
16	Left Position Sensor*
17	Lower Board Anti-Pullback Lever Sensor
18	Not Used

\* The left and right sensors referenced above are given viewing the BA32R from the front.

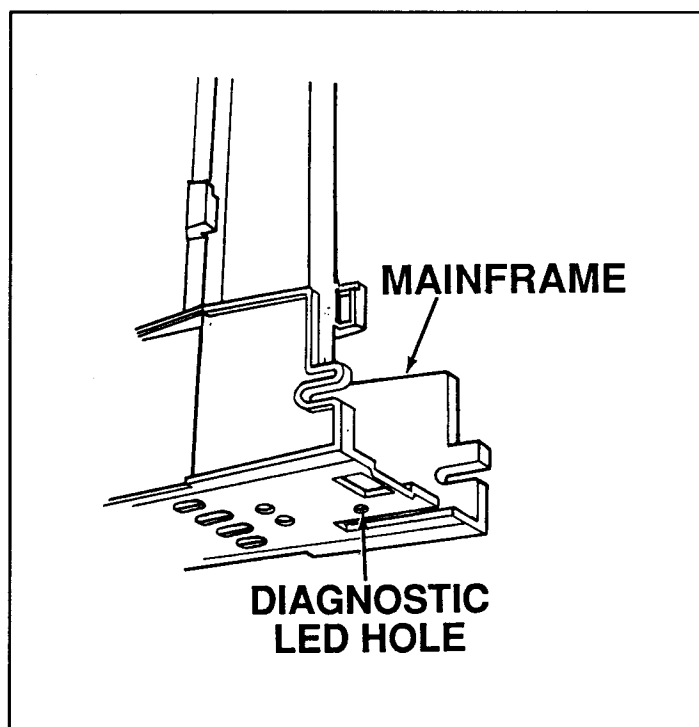
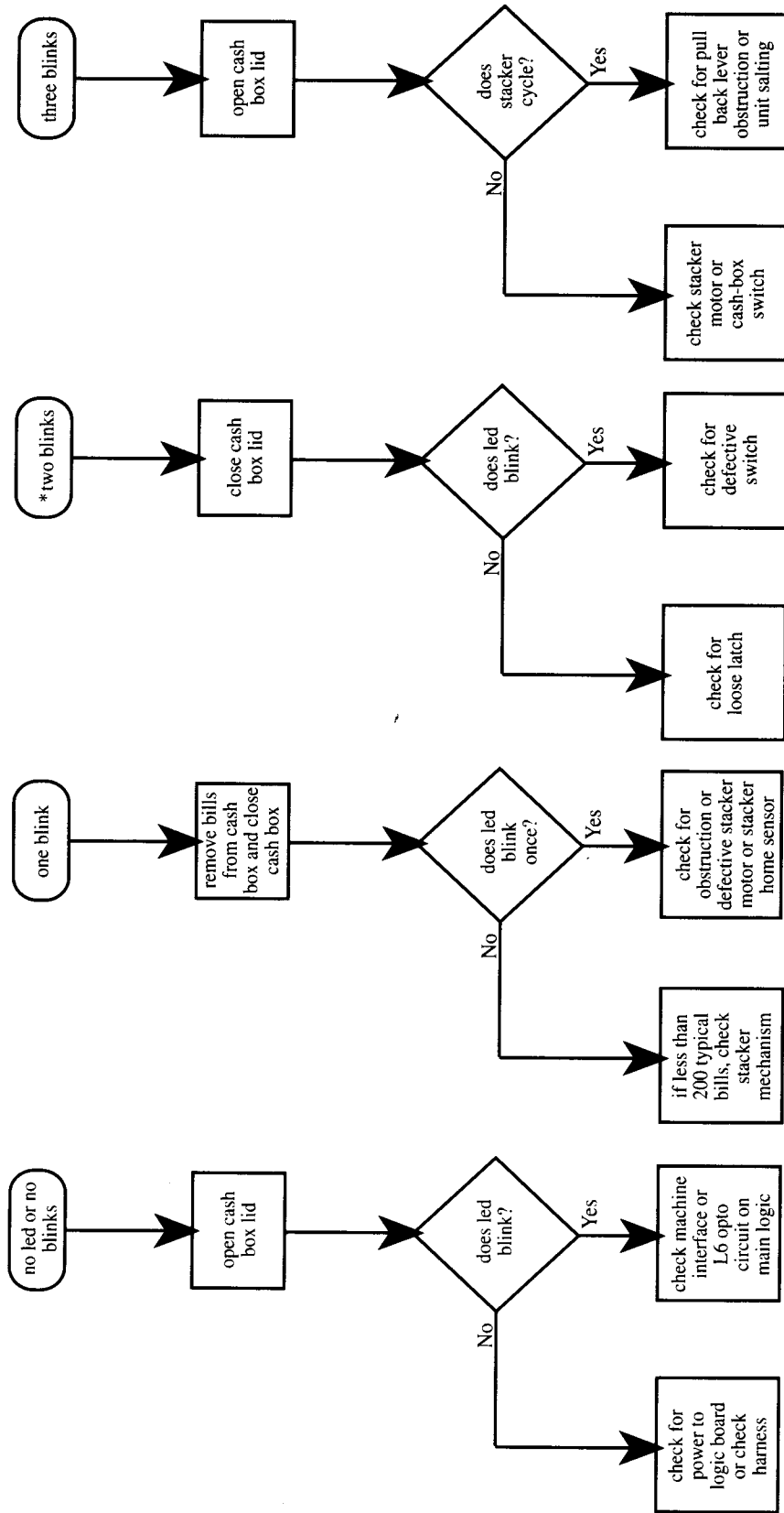

Figure 19

# SECTION 5: TROUBLESHOOTING

## TROUBLESHOOTING GUIDE



\* Bill box diagnostic code used on BA30B model only.

# SECTION 5: TROUBLESHOOTING

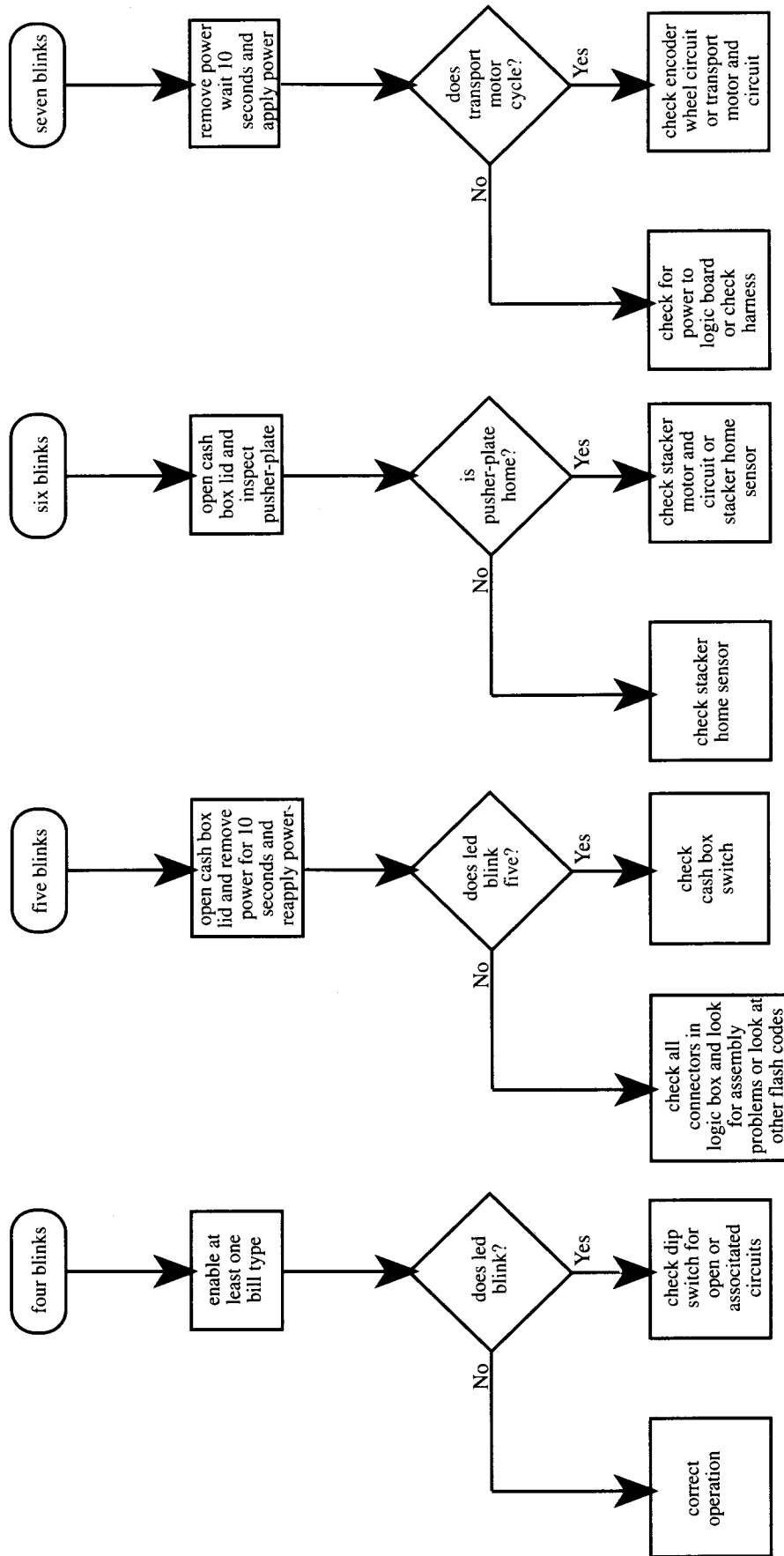

# SECTION 5: TROUBLESHOOTING

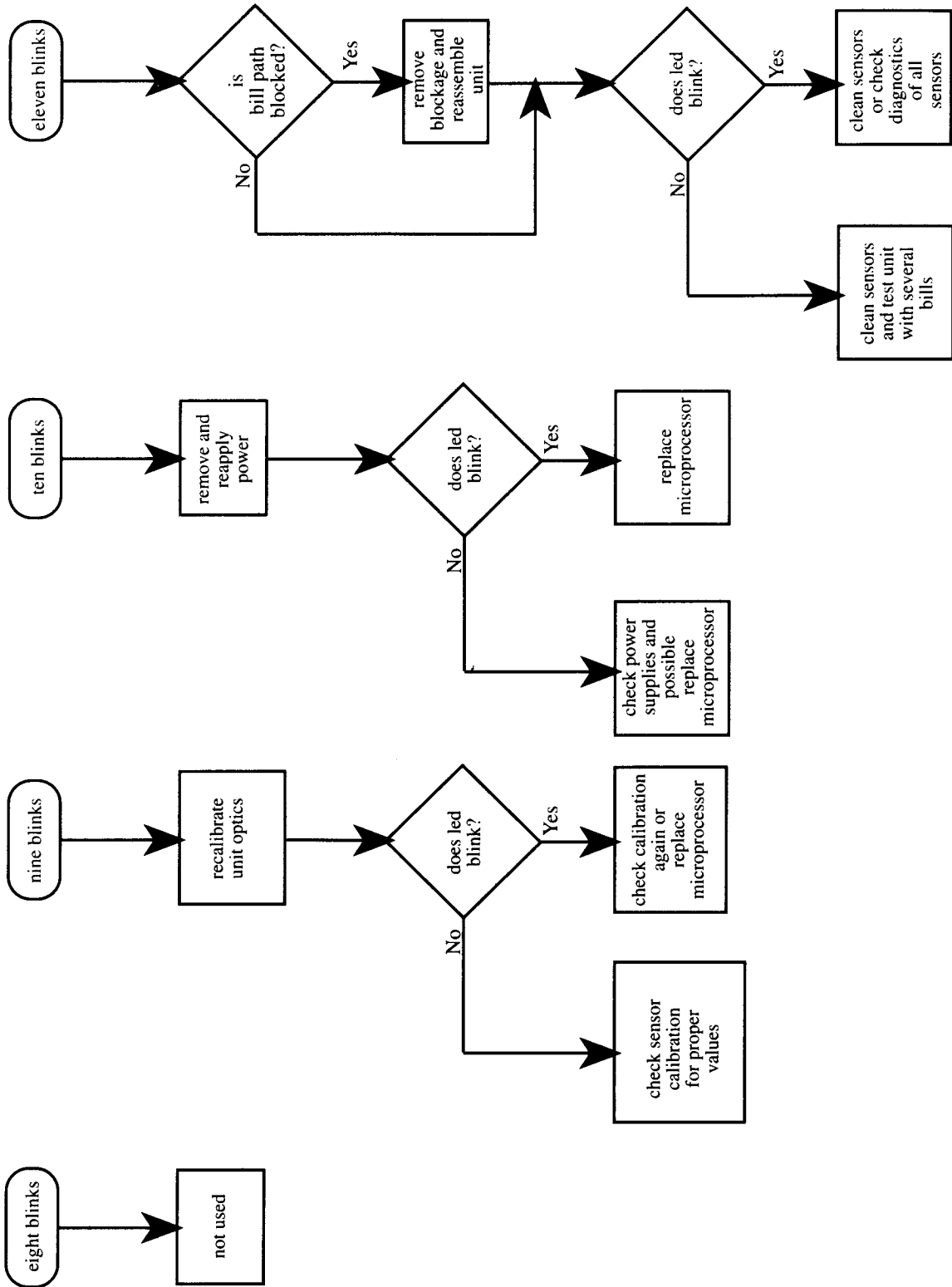

# SECTION 5: TROUBLESHOOTING

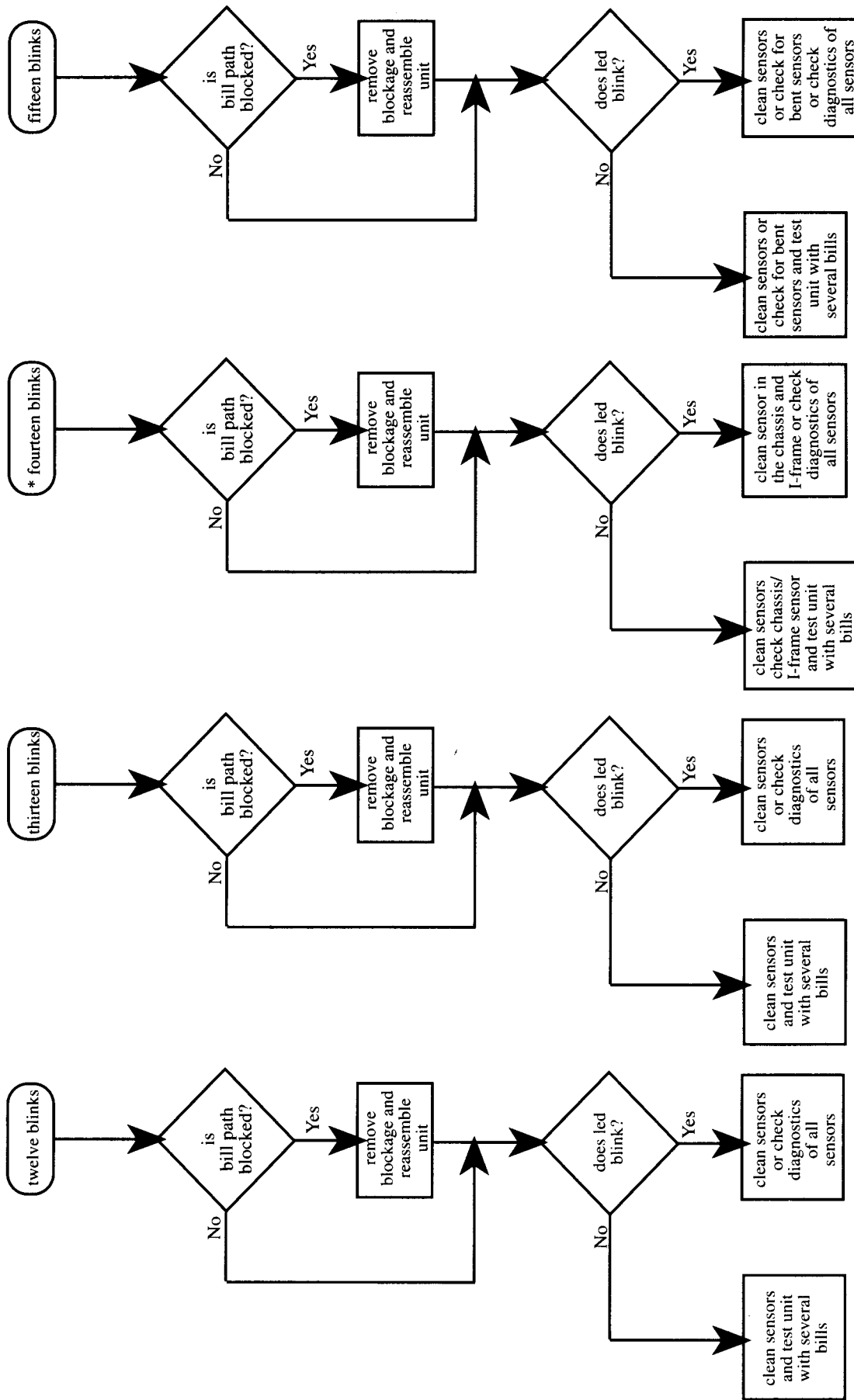

\* Units with serial numbers 109300187 or later, do not have a bill position sensor.

# SECTION 5: TROUBLESHOOTING

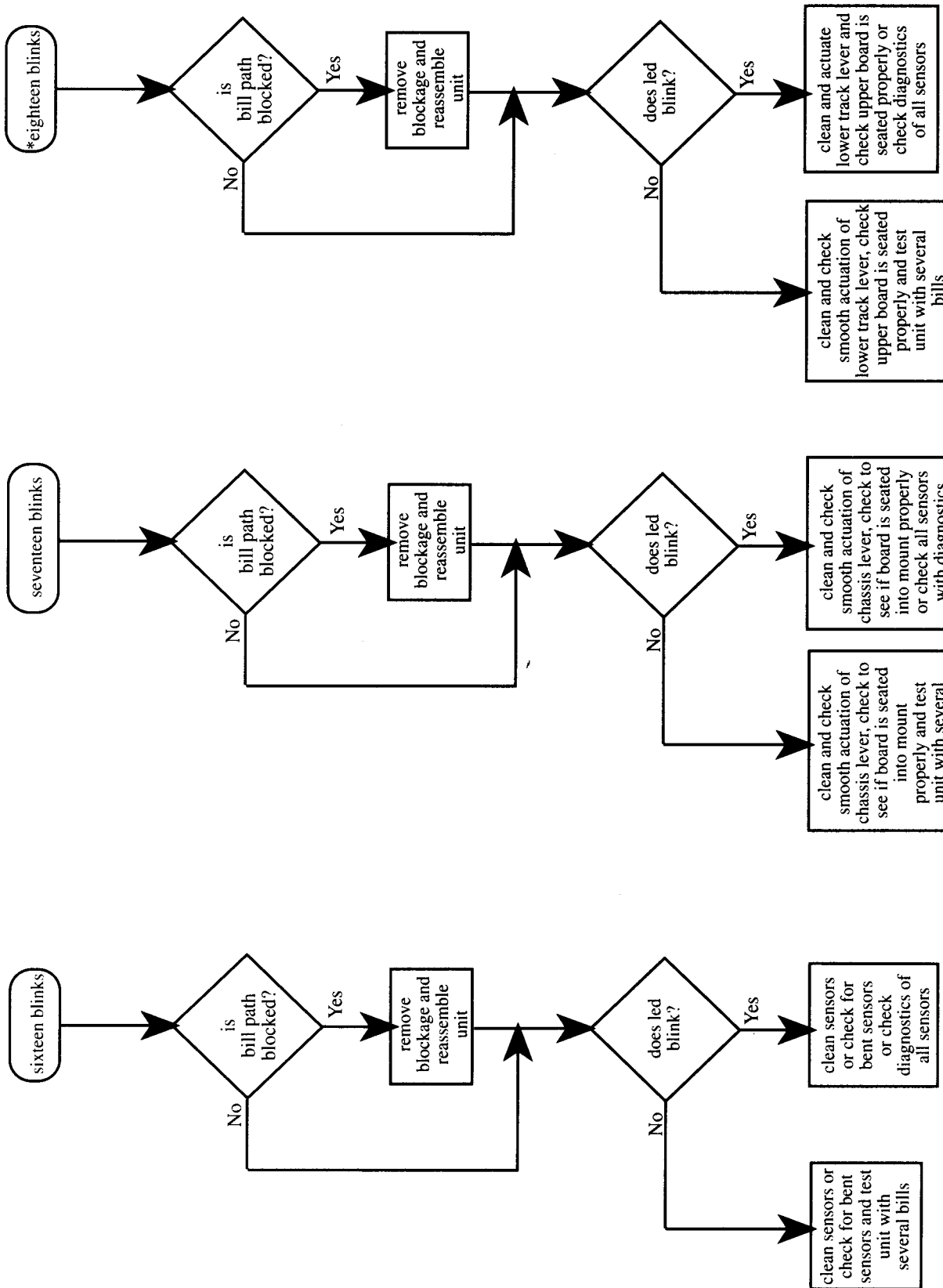

\* Units with serial numbers 359300001 or later, do not have a chassis anti-cheat sensor.

# SECTION 6: PARTS LIST

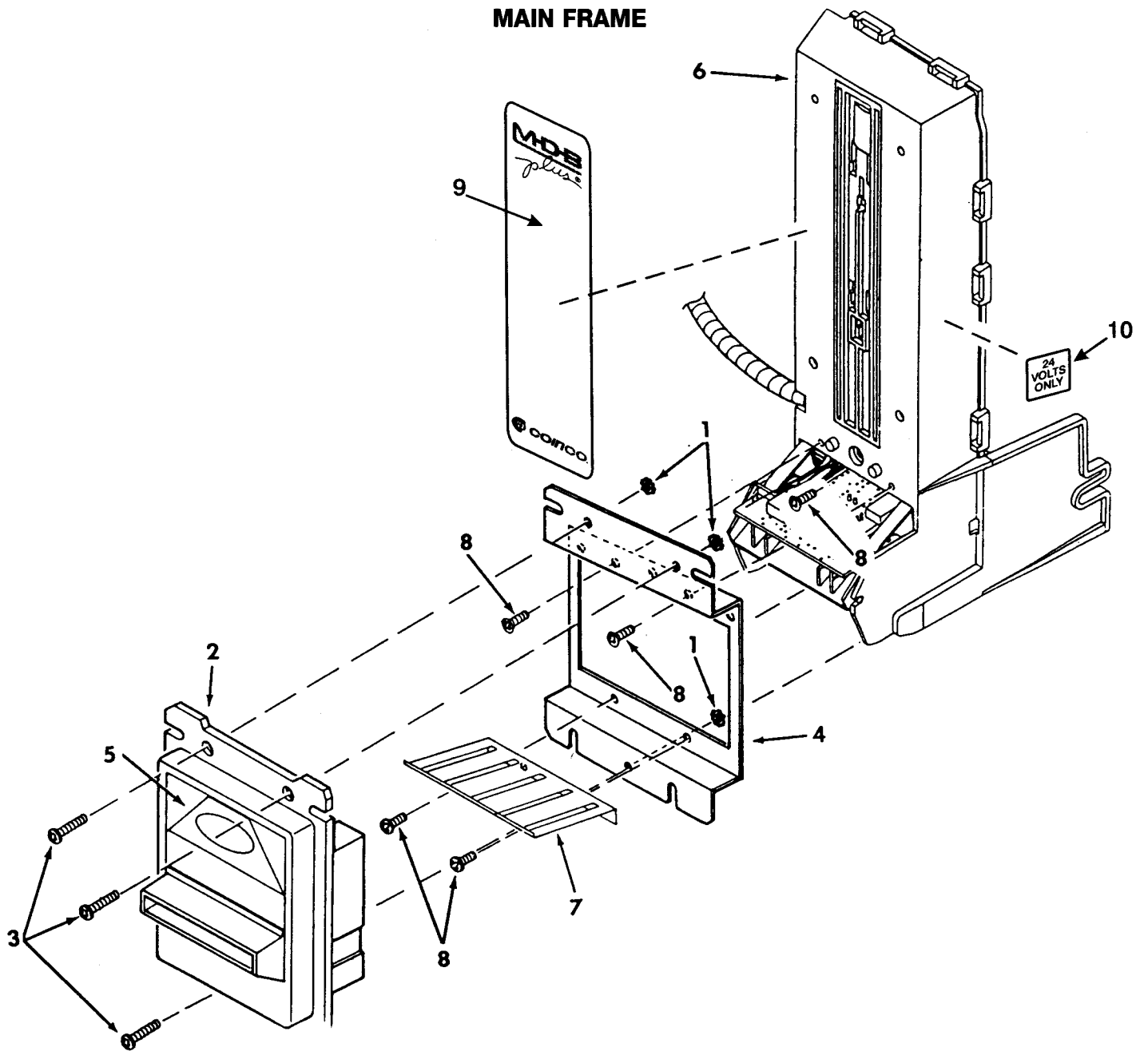

ITEM NO.	PART NO.	DESCRIPTION	QUANTITY
1	438-6	Nut & Lockwasher 6-32	3
2	921367	Snack Mask	1
	922015	Snack Mask (Pad Printed)	
3	921401	Screw	3
4	921492	Frame Mount	1
5	921629	Label, Bill Insert	1
6	920807-3	Main Frame	1
7	921357	Grounding Spring	1
8	3456R6	Screw, 6 x 3/8	5
9	922009	MDB Decal	1
10	902224	24 Volts Decal	2

# SECTION 6: PARTS LIST

## CHASSIS ASSEMBLY 407249-7

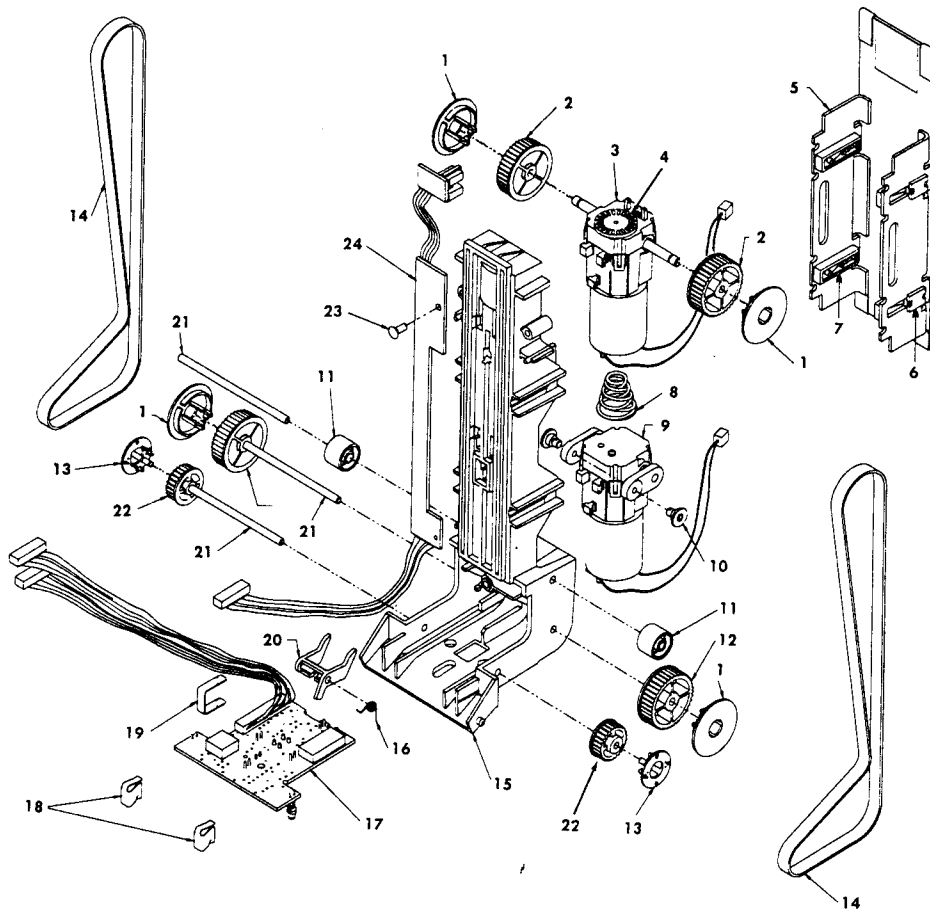

ITEM NO.	PART NO.	DESCRIPTION	QUANTITY
1	902824-1	Hub, Transport Pulley	4
2	920823-2	Pulley, Upper Transport	2
3	407254-1	Gearbox Assy., Transport (includes #4)	1
4	920000-3	Wheel, Encoder	1
5	407252-1	Stacker Assembly (includes #6 and #7)	1
6	920836	Stacker Cap	4
7	920833-1	Stacker Slide	4
8	921387	Spring, Belt Tension	1
9	407253-1	Gearbox Assembly, Stacking	1
10	920834-1	Screw, Bearing	2
11	920829-1	Pulley, Idler	2
12	920823-3	Pulley, Lower Transport	2
13	920004-1	Hub, Timing Wheel, .670	2
14	921403	Belt, Chassis, Black	2
15	920821-2	Chassis, Upper Housing	1
16	920889	Spring, Anti-Pullback	1
17	407244-9	Sensor Board, Upper	1
18	920827	Clip, Upper Board	2
19	921128	Clip, Wire	1
20	920828-1	Lever, Anti-Pullback	1
21	920040	Shaft, Wheel	3
22	920825-1	Pulley, Inlet	2
23	345-4R4	Screw, 4x1/4 PH Plastite	1
24	407246-5	Stacker Board	1



# SECTION 6: PARTS LIST

## LOWER HOUSING ASSEMBLY 407248-9

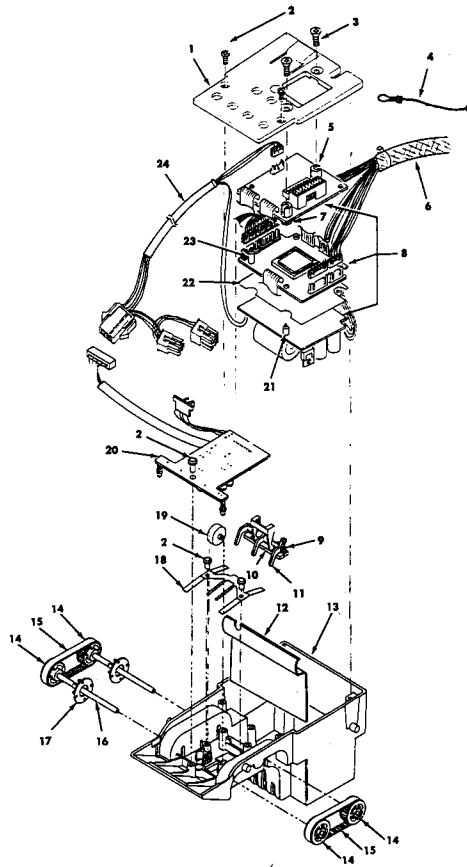

ITEM NO.	PART NO.	DESCRIPTION	QUANTITY
1	921704	Bottom Cover	1
2	345-4R4	Screw, 4 1/4 PH Plastite	5
3	1026R6	Screw, 6-32 x 38	2
4	407454	Harness, Ground	1
5	921648-6	Spacer, PCB 3/8	2
6	921707	1/2" Expandable Sleeving	1
7	921647	Nut, Nylon	2
8	407493-1	Logic Board	1
9	920889	Spring, Anti-Pullback	1
10	920819	Mount, Anti-Pullback	1
11	920818	Lever, Anti-Pullback	1
12	921631	Shield	1
13	920806-2	Lower Housing Frame	1
14	920003-1	Pulley, Timing, .870	4
15	920815	Belt	2
16	920040	Shaft, Wheel	2
17	920004-1	Hub, Timing Wheel	4
18	921055	Spring, Mag Roller	1
19	922508	Shaft, Roller Assembly Mag	1
20	407245-10	Sensor Board, Lower	1
21	921644-3	Support Post, 3/16	2
22	921649	Insulation	1
23	921644-6	Support Post, 3/8	2
24	407531	Harness, Power	1

# SECTION 6: PARTS LIST

## INTERMEDIATE FRAME ASSEMBLY 407247-2

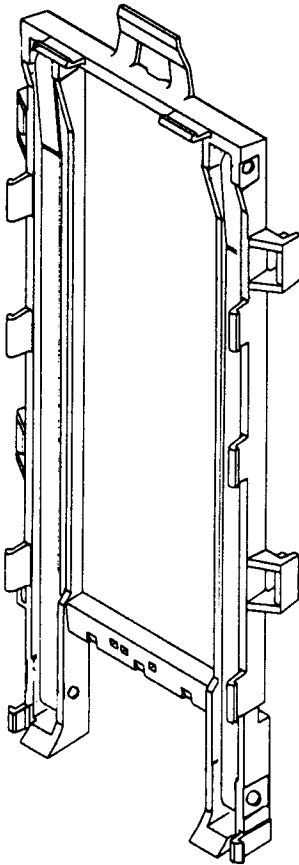

## CASHBOX ASSEMBLY

407251 (300 CAPACITY)  
407763 (450 CAPACITY)

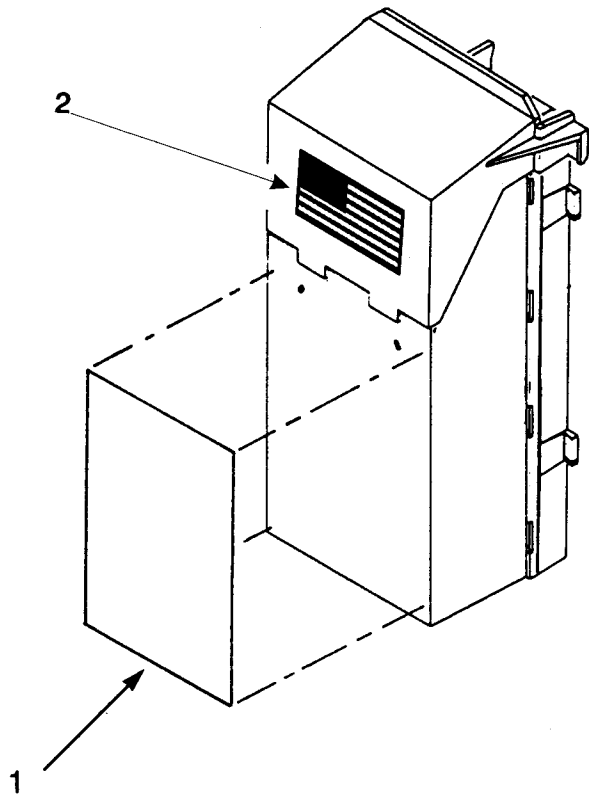

ITEM NO.	PART NO.	DESCRIPTION	QUANTITY
1	921221	Decal, Instruction	1
2	909213	U.S. Flag Decal	1





**COIN ACCEPTORS, INC.**  
300 Hunter Avenue  
St. Louis, MO 63124-2013  
(314) 725-0100

Coinco Publication No. 922003 Rev. 1  
9/97 Printed in the U.S.A.