

9302-GX SERIES ELECTRONIC CHANGER

Operation and Service Manual

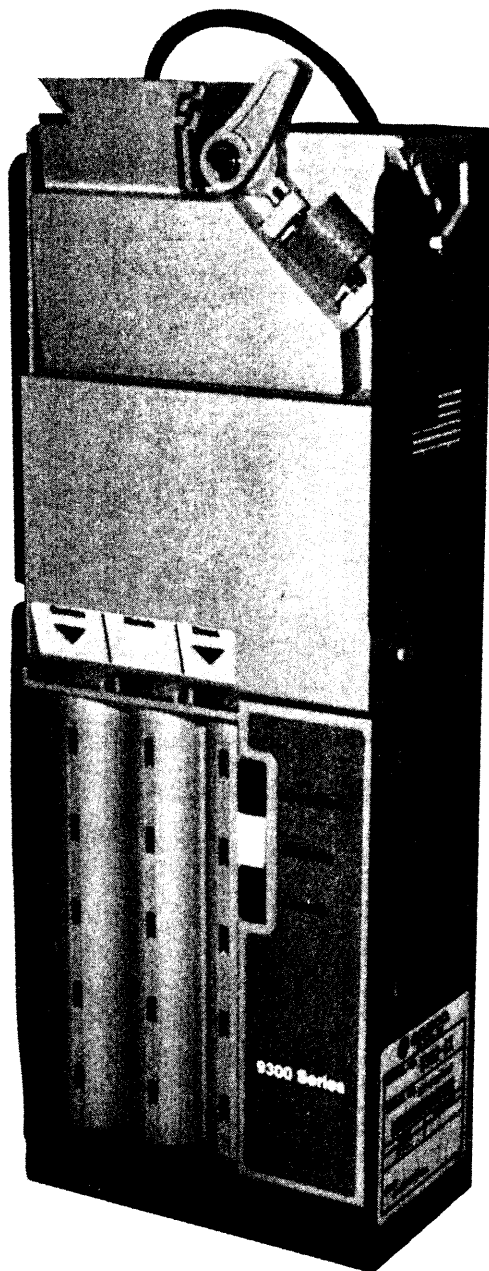

 **coinco**®

Table of Contents

Section 1: General Information

Introduction	3
For Your Records	3
Features	3
After Unpacking	3
Specifications	4

Section 2: Installation

Installing the Changer	5
Option Switch Setting	5

Section 3: Operation

Coin Recognition	6
Coin Separation	6
Rejected Coin	6
Accepted Coin	7
Credit & Accumulation	8
Vend	8
Coin Payout	8
Change Storage	9
Correct Change Operation	9
Escrow Return	9
Interface with Vendor/Controller	9

Section 4: Maintenance

Routine Maintenance	11
Removing/Replacing Individual Module Assemblies	11
Cleaning	11
Clearing Coin Jams	12

Section 5: Bench Check Procedure

Bench Check Procedure	13
Tester Error Codes	16

Section 6: Troubleshooting

Introduction	17
Troubleshooting Guide	17
Wiring Diagram	20

Section 7: Exploded Views

Modular View	21
Changer Housing	22
9302-GX Payout Assembly	23
Logic Board Cover Assembly	24
Inventory Tube Assembly	24
Acceptor Front View	25
Acceptor Back View	26

Section 1: General Information

INTRODUCTION

This manual contains information on installing, operating and maintaining Coinco's **9302-GX** coin changer. This manual is intended for owners, route operators and shop-level technicians as a primary source of information. Taking time to read this manual and becoming familiar with this information will help you obtain the best performance from your Coinco **9302-GX** coin changer.

FOR YOUR RECORDS

A label indicating the coin changer model number and serial number is affixed to the side of the coin changer. Refer to the model and serial number whenever you call upon your Coinco Service Center for information or service. The first four digits of the serial number contain the manufacturing date code which indicates the beginning of the warranty period.

***EXAMPLE:** Serial No. 269107053. First and second digits indicate week of manufacture. Third and fourth digits indicate year of manufacture.*

FEATURES

- Accepts U.S. nickels, dimes, quarters and dollar coins.
- Pays out nickels, dimes and quarters from self-loading, high capacity change tubes.
- Change capacity of \$40.55.
- Modular design for easy service.
- Select high or low quarter tube level by simply flipping a switch.
- Heavy-duty D.C. payout solenoids provide fast, accurate payout.
- State-of-the-art electronic logic system is designed for reliability and performance.
- Lightweight, rugged plastic construction provides dependable, maintenance-free service.
- Provides the fastest and most accurate coin acceptance of any electronic unit available today.

AFTER UNPACKING

After unpacking the unit, inspect if for any possible shipping damage. If the unit is damaged, notify the shipping company immediately. Only the consignee (the person or company receiving the unit) can file a claim against the carrier for shipping damage. We recommend that you retain the original carton and packing materials to reuse if you need to transport or ship your changer in the future.

If the coin changer is being stored or used as a spare, always keep it in its shipping carton when not in use. This will keep it clean and offer the best protection for the unit.

Section 1: General Information

SPECIFICATIONS

Power Requirements

- 34VDC
- 3.6 Amp max. at 26VDC for 100 ms every 500 ms during payout
- 750 m Amp max. for 1 second for each coin accepted
- 200 m Amp. max standby

Operating Temperature

0 to 150 Degrees Fahrenheit
 -18 to 65 Degrees Celsius

Storage Temperature

-22 to 160 Degrees Fahrenheit
 -30 to 72 Degrees Celsius

Relative Humidity

20% to 98% Noncondensing

Operating Attitude

Vertical ± 3 degrees

Physical Dimensions

Height: 14.81 inches high
 (base to top of coin return lever)
 Width: 5.28 inches in width
 (acceptor latch to acceptor latch)
 Depth: 2.86 inches (gate closed)

Physical Weight in Shipping Carton

4 pounds

Coin Tube Capacity

	5¢ tube	10¢ tube	25¢ tube	
			LO 25¢ Option Switch Set To OFF Position	LO 25¢ Option Switch Set To OFF Position
Low Sensor Level	7	9	7	7
Full Sensor Level	78	113	77	22
Hand Load Level	86	125	95	22

Section 2: Installation

INSTALLING THE CHANGER

1. Remove power from vendor.
2. Remove the acceptor from the changer by releasing acceptor latches and pulling the top of the acceptor forward, away from changer. Unplug ribbon cable from changer. Free lower acceptor studs from changer housing. With the acceptor removed, set key holes in back of changer housing over mounting screws in the vendor. Tighten snugly.
3. Set desired changer options (See Option Switch Setting).
4. Replace the acceptor by inserting bottom acceptor studs into changer housing guides. Plug the acceptor ribbon cable into the changer. Press top of acceptor into changer housing until top acceptor studs lock into changer's acceptor latches.
5. Plug changer into 6-pin vendor socket.
6. Load coin tubes making sure all coins lie flat.
7. Apply power to vendor.
8. Test changer with a variety of coins to ensure proper operation.

NOTE: SAVE THE COIN CHANGER CARTON. Always store coin changer in its shipping carton when not in use. This will keep the unit clean and protected.

OPTION SWITCH SETTING

See Figure 2.0

1. Hinge acceptor down by releasing acceptor latches and pulling the top of the acceptor forward, away from changer.
2. Located in the upper portion of the changer, behind the acceptor, is a single switch module containing three rocker switches. When the top of the rocker switch is pushed in, it is in the ON position. The switches correspond as follows:

A=USA/CAN Not Used*
B=LO 25¢ ON: Quarters are directed to cash box once change tube has approximately 22 quarters
OFF: Quarters are put into change tube until it is full.

C=\$ACPT ON: Dollar coin will be accepted
OFF: Dollar coin will be rejected

3. Set option switches to desired setting.
4. Return acceptor to operating position making sure acceptor latches secure acceptor.
5. Test with a variety of coins to ensure proper operation.

* For units manufactured prior to the 38th week of 1997, Switch A was factory tuned for the acceptance of Canadian coins. With Switch A ON, U.S. and Canadian coins were accepted. With Switch A OFF, Canadian coins were rejected.

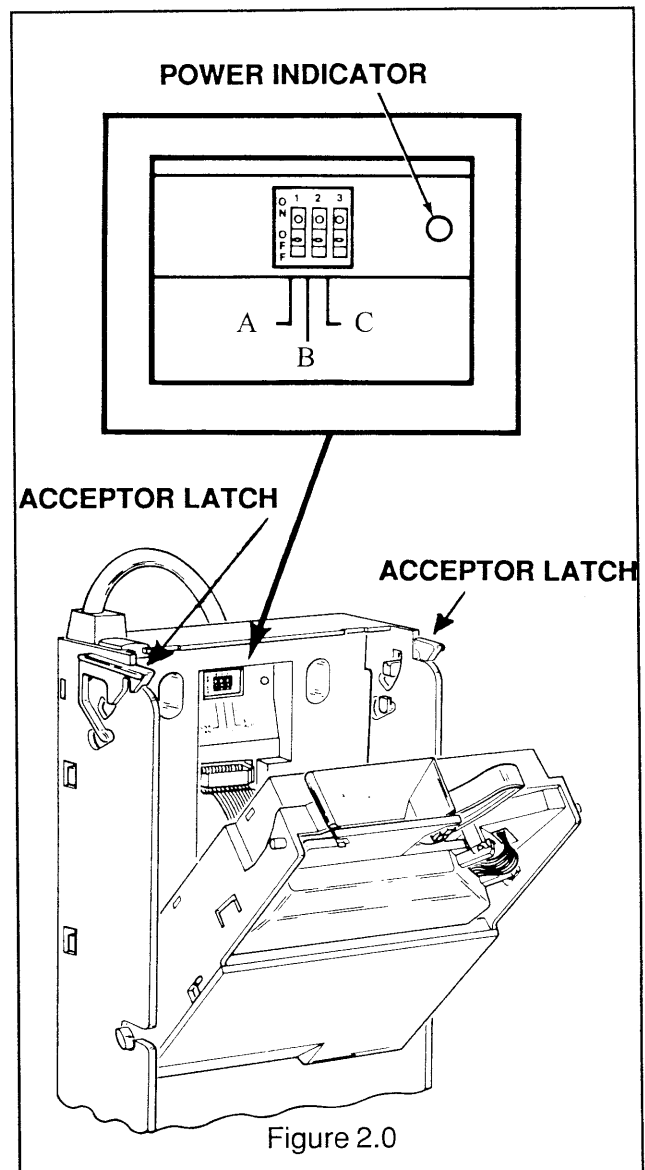

Section 3: Operation

COIN RECOGNITION

See Figure 3.0

As a coin enters the changer through the acceptor funnel, its impact is absorbed by a white ceramic rail which debounces the coin and allows it to continue down the coin rail at a smooth and steady speed. As a coin rolls down the rail, it passes between two sets of LED sensors which measure the speed and size of the coin. The coin also passes between two sets of coils which measure the metallic content of the coin. These measurements are used to determine if the coin is valid and the value (denomination) of the coin.

COIN SEPARATION

See Figure 3.0

After the coin's validity has been determined the coin rolls off the end of the coin rail and enters the separator section of the acceptor. The UPPER (coin tube) gate and the LOWER (cash box) gate are opened and closed by their respective solenoids. These solenoids are energized and de-energized by an electrical signal from the acceptor logic board based on the following criteria:

- the validity of the coin.
- the denomination of the coin.
- the status (full or empty) of the appropriate coin tube.

The positions of these two gates cause the coin to be routed to one of three places: the appropriate changer coin tube, the vendor cash box, or if the coin is rejected, the vendor coin return cup.

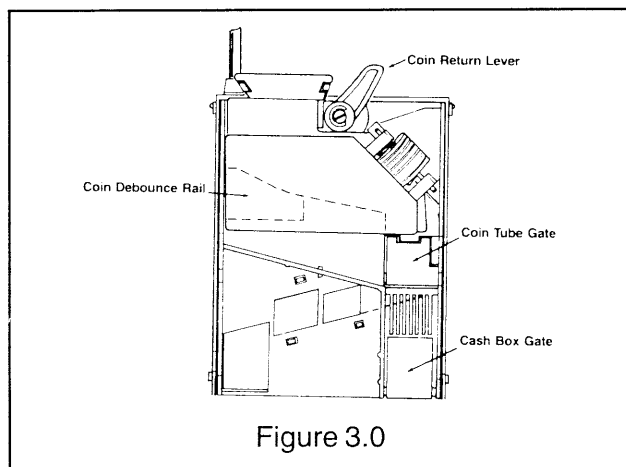

REJECTED COIN

See Figure 3.1

If a coin is rejected for any reason, both the UPPER (coin tube) and the LOWER (cash box) gate will remain closed. All rejected coins will drop into the vendor return cup via the coin changer coin return chute.

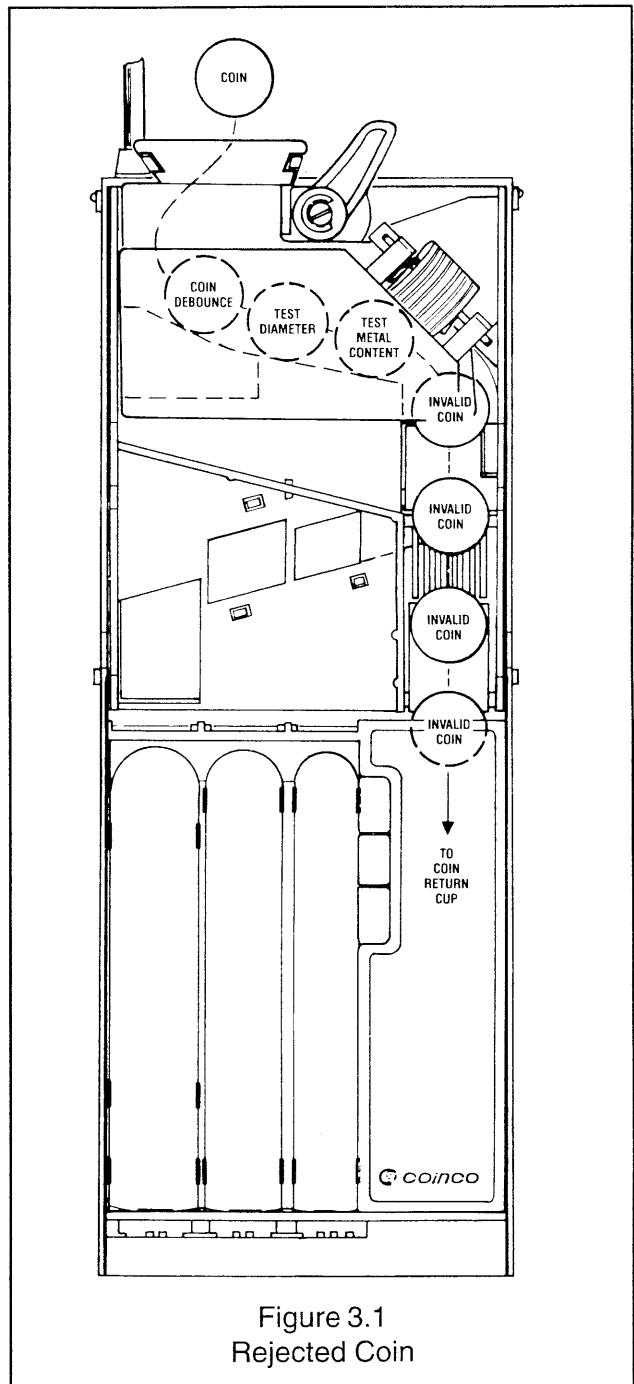

Section 3: Operation

ACCEPTED COIN

See Figures 3.2 and 3.3

An accepted coin will be routed to either the vendor cash box or to one of the change coin tubes. The (FULL) sensors in each coin tube determine which route the coin will take. If the coin tube corresponding to the validated coin is full (full sensor covered by coins in change tube), the cash box gate will open, allowing the coin to

drop into the vendor cash box via the changer cash box chute. If the appropriate coin tube is not full (full sensor not covered by coins), the coin tube gate will open directing the coin down a ramp. Along the wall of the ramp are windows for entry into the coin tube. As the coin reaches a window of the appropriate size, it falls into the coin tube. All dollar coins are always directed to the cash box via the cash box chute.

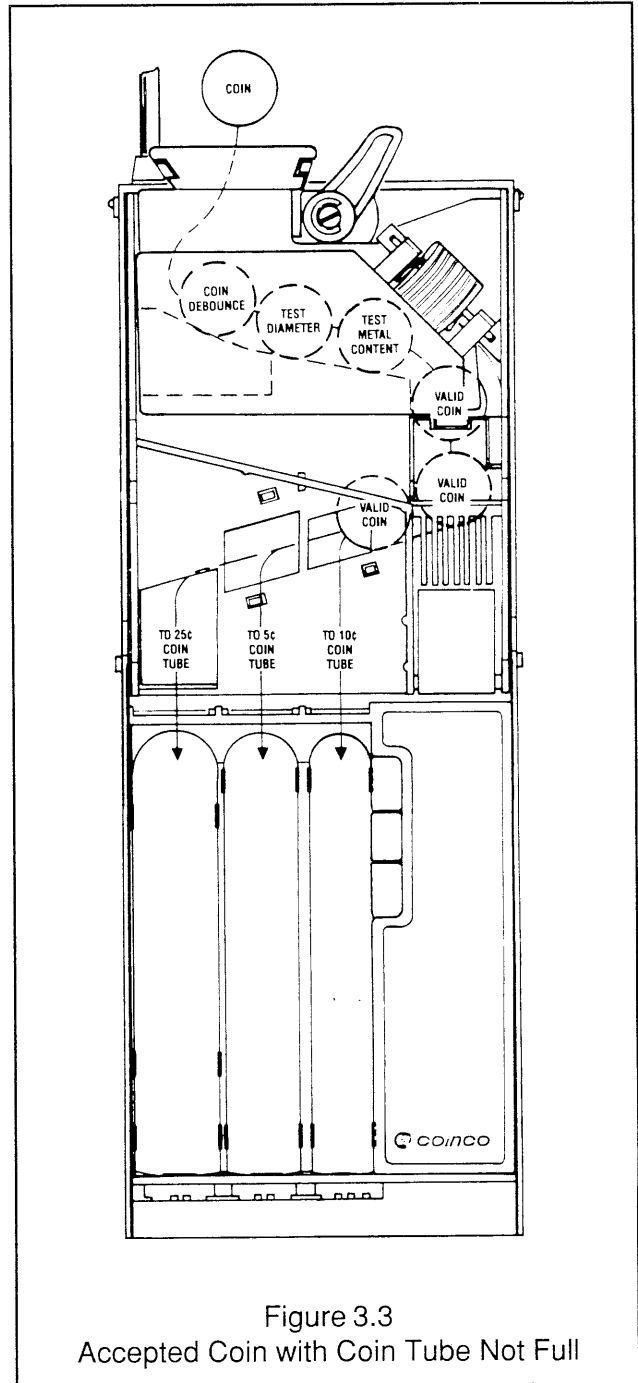
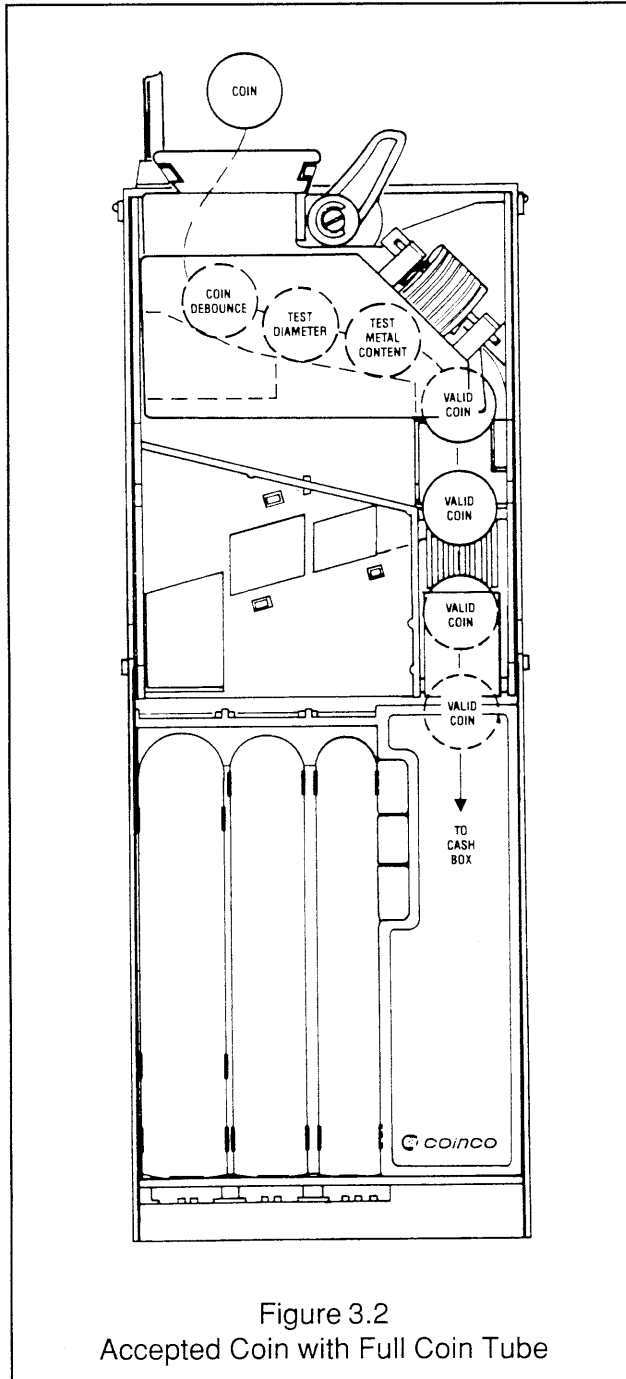

Section 3: Operation

CREDIT AND ACCUMULATION

See Figure 3.4

There are two sensors, one in the separation section of the acceptor and one in the cash box path of the acceptor. As coins pass either one of these sensors, the changer sends credit information to the vendor electronic controller where the coin credit is accumulated.

VEND

Vend is a function of the vendor electronic controller. The vendor controller accumulates all credit information received from the coin changer. As credit is accumulated in the vendor controller, vend selections can be made when their respective vend price settings are equalled.

COIN PAYOUT

Coins are paid out from the coin changer when a change payback is required or when either of the coin changer inventory switches are manually operated. Coins are dispensed by D.C. solenoid-operated slides located at the bottom of each of the three coin tubes. The payout solenoids are controlled by signals generated by the vendor controller or the three inventory switches.

When a solenoid energizes, the upward motion of its plunger compresses a spring and draws the solenoid lever, which in turn pushes a payout slide forward. This loads the coin for payout. When the solenoid de-energizes, the spring force returns the plunger to its de-energized state, which returns the solenoid lever and payout slide, dispensing a coin. Coin payout rate is determined by the vendor electronic controller board.

Inventory Switches

Located on the front of the coin changer is a nickel, dime and quarter inventory switch. These switches are used to manually remove coins from the changer coin tubes. They are disable while the vendor is in a vend cycle.

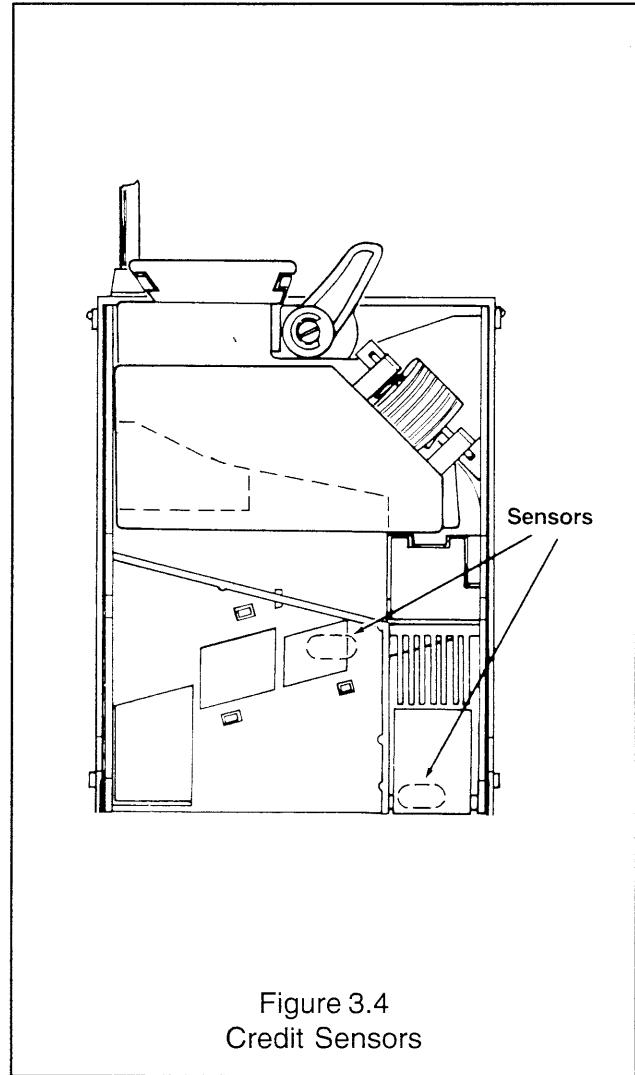

Figure 3.4
Credit Sensors

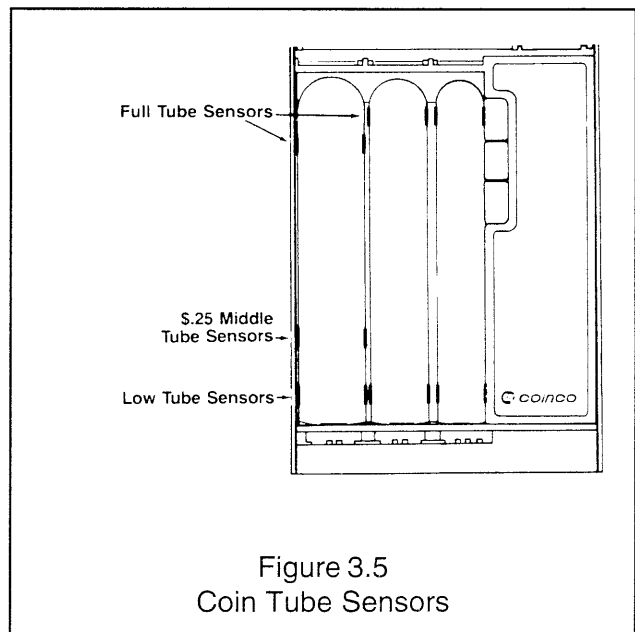

Figure 3.5
Coin Tube Sensors

Section 3: Operation

CHANGE STORAGE

See Figure 3.5

The full tube sensors in each coin tube continually report the (full/not full) status to the coin changer logic board. The information is then used to determine the placement of the next accepted coin. This information controls the action of the acceptor coin tube and cash box gates.

EXAMPLE: *If the quarter tube is full (full sensor blocked by coins) the acceptor coin tube gate will remain closed and the cash box gate will open each time a quarter is accepted, routing all quarters to the vendor cash box via the changer coin chute.*

After one or more quarters are paid out as change, leaving the full sensor exposed (not full), the acceptor coin tube gate will open each time a quarter is accepted, routing quarters to the changer coin tube until it is full again. NOTE: If the changer (LO-\$.25) option switch is set to the ON position, accepted quarters will be routed to the cash box when the (middle \$.25 tube sensor) is blocked by coins.

The low tube sensors in each coin tube continually report the (blocked/not blocked) coin level status to the vendor controller. This information is used to determine if change is available for payout.

CORRECT CHANGE OPERATION

The coin changer continually reports the status of the low tube sensors to the vendor's controller. The logic control for correct change is initiated by the vendor controller.

ESCROW RETURN

Escrow return is a function of the vendor electronic controller. Coins are always accepted regardless of the coin tube levels.

The value of each coin is accumulated in the vendor controller. If a coin return is requested, a signal is sent to the appropriate payout solenoid(s) to pay back coins of the same denomination. If a dollar coin has been accepted,

change will be returned in the least number of coins possible if an escrow return is requested.

INTERFACE BETWEEN THE 9302-GX COIN CHANGER AND VENDOR / CONTROLLER

See Figures 3.6 and 3.7

The 9302-GX changer's interface connector is shown in Figure 3.6. Figure 3.7 shows the interface between the 9302-GX, vendor and electronic controller.

Section 3: Operation

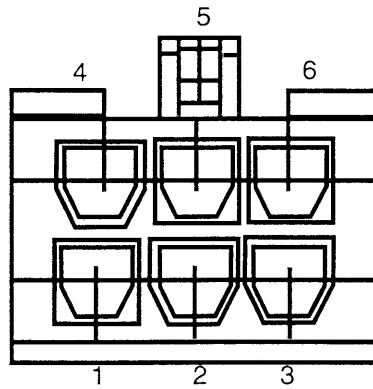

Figure 3.6
Coin Changer Plug

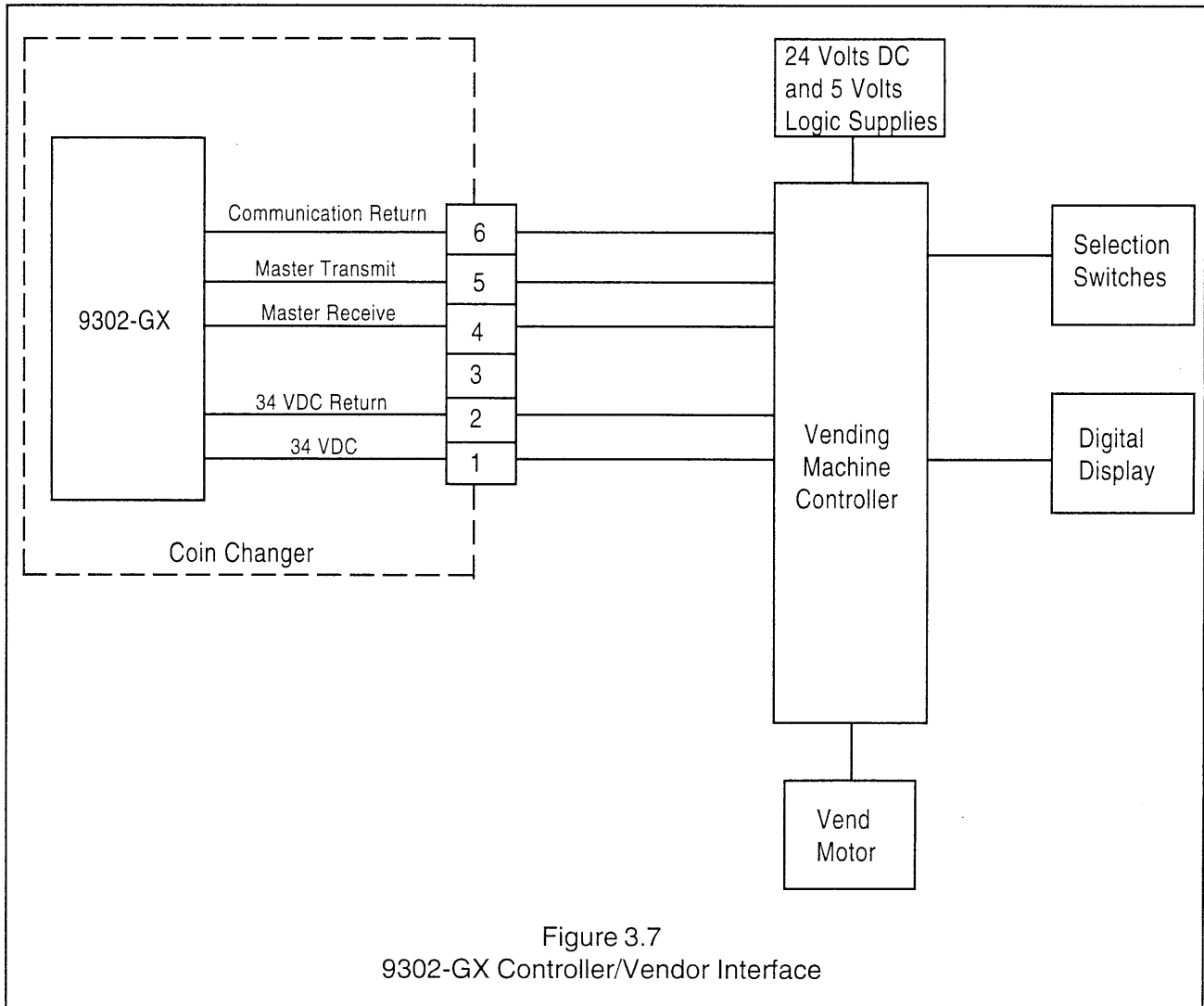

Figure 3.7
9302-GX Controller/Vendor Interface

Section 4: Maintenance

ROUTINE MAINTENANCE

Routine maintenance will improve performance and extend the working life of the 9300 series changer and reduce the need for more involved repairs. Frequency of routine maintenance will depend on environment and number of transactions.

The coin changer should be kept in its original shipping carton when not in use. This will keep the changer clean and afford the best protection for the unit.

REMOVING/REPLACING INDIVIDUAL MODULE ASSEMBLIES

Modular assembly replacement provides the basis of all 9300 series changer repair. Instructions for removing and replacing modules are provided below. These modules should be removed in the following sequence:

Acceptor

To remove the acceptor, raise the two acceptor latches and pull the top of acceptor forward and away from the changer housing. Unplug acceptor ribbon cable from main logic board. Raise acceptor and pull outward until the acceptor clears the housing slots.

Coin Tube and Sensor Assembly

Remove logic board cover by spreading the changer housing slightly and pulling up on the board cover. Unplug tube sensor ribbon cable from logic board. Spread the lower part of the housing slightly and pull out on tube assembly. To separate the coin tube assembly from the tube sensor board assembly, place the assembly face down. While freeing the four locking tabs, pull up on tube sensor board. Be careful not to damage sensors on logic board.

Main Logic Board Assembly

Unplug payout solenoids, and main harness assembly from logic board. Lift logic board out of housing.

Payout Assembly

With payout solenoids disconnected from main logic board, remove the four screws - two from each side - at the bottom of the housing. Separate payout assembly from changer housing by releasing cash box chute locking tab on back of changer housing and pulling downward on payout assembly.

CLEANING

Your 9302-GX changer is made of a high-quality industrial grade plastic which should only be cleaned with a warm water and mild detergent solution.

CAUTION:

- *Never submerge changer in water.*
- *Do not use petroleum solvents, steel wool, scouring pads, or a metal brush for cleaning.*
- *Do not spray any part of changer with any type of lubricant.*

Since all coins share a common coin ramp, heavy usage or a dirty environment can result in dirt build up. To clean the coin ramp, lift the acceptor gate upward and diagonally to the right. Hold gate firmly to prevent it from snapping back. Wipe the exposed coin ramp and inner surface with a damp cloth. For excessively dirty units, use a damp cloth with a mild detergent.
NOTE: *Do not submerge in water.*

For detailed cleaning of the acceptor, remove the front cover by pulling out and down of the front cover. Now remove the back cover by pushing in on two locking tabs on the side of the acceptor. To remove the coin sorting rail, snap the coin sense coils from the sorting rail and the cash box exit, being careful not to break coil wires. Free coil wires from the clip on the sorting rail. Now from the front of the acceptor, in area exposed by removing the front cover, locate the three locking tabs which secure the sorting rail. Using a small straight tip screwdriver, free the three locking tabs and remove sorting rail. See Figure 4.0.

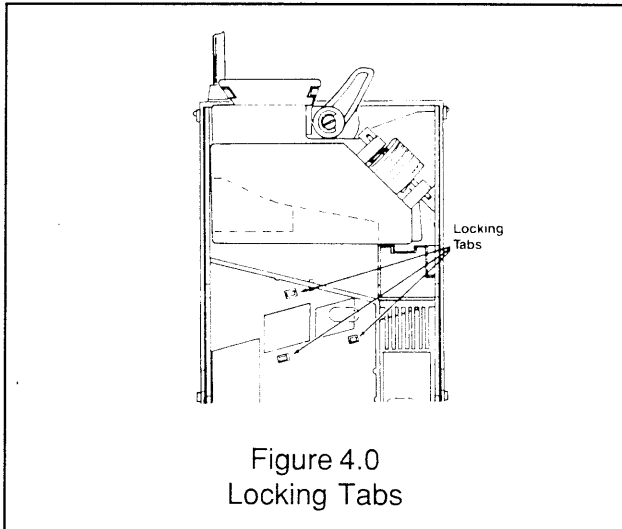

Figure 4.0
Locking Tabs

DISASSEMBLING PAYOUT BASE FOR CLEANING

Remove the four Phillips head screws from the bottom plate. Remove bottom plate and individual slides. Clean parts with mild detergent and hot water as desired. **DO NOT SUBMERGE SOLENOIDS IN WATER.**

Replace slides making sure part numbers face up into changer. With the slides correctly seated on plunger tabs, reinstall the bottom plate, securing with bottom screws. Reinstall payout module into changer, securing with side screws.

CLEARING COIN JAMS

Should a coin jam occur in the cash box chute area, use the following steps to help dislodge coins:

1. Remove changer from vendor.
2. Keeping changer in an upright position, insert a narrow screwdriver into cash box chute or reject chute from bottom of changer to relieve jam. Access holes are also provided at the rear of the changer housing to help relieve coin jam.

CAUTION: Excessive screwdriver pressure or twisting can cause permanent damage to the coin changer.

Section 5: Bench Check Procedure

BENCH CHECK PROCEDURE FOR MODEL 9302-GX Using Coinco Tester #407341

NOTE: This tester is a static sensitive device and must be used in a grounded work station.

PROCEDURE	RESULT	FUNCTION VERIFIED
Set changer Coin Control Option switches as follows: #1: (OFF) Not Used. #2: (OFF) HI \$.25 change tube. #3: (OFF) No \$ coin accept		
Plug changer into tester. Set tester power switch ON.	The digital display and tube sensors upper and lower LED's sequence, then the display will read rSt	Power Up - Reset
Set the changer Enable/Disable switch to the Disable (down) position and insert (1) nickel, (1) dime and (1) quarter	All coins are rejected. Digital display reads r.05, r.10, r.25 for respective coins when rejected	Coin reject (blocker function)
Set the changer Enable/Disable switch to the Enable (up) position and insert (1) nickel, (1) dime and (1) quarter	Coins are accepted, and directed to the respective changer coin tube, digital display will read: t.05 when nickel is deposited t.10 when dimes is deposited t.25 when quarter is deposited	Coin accept (accepted function)
Actuate Changer Reset Switch	Digital display will read rSt <i>NOTE: If reset switch is held in, the changer's communication software revision will be displayed.(Sr2) When the reset switch is released, display will read rSt</i>	Reset
Randomly insert (9) nickels, (11) dimes, and (9) quarters	Coins are accepted and directed to changer coin tube, digital display will read t.05, t.10, t.25 for respective coin when the 9th, 11th & 9th coin respectively is inserted, the low tube sensor LED will light. Example: When the 9th nickel is accepted, the digital display will read t.05 and the lower tube sensor LED will illuminate.	Coin accept Low change tube sensors

Section 5: Bench Check Procedure

PROCEDURE	RESULT	FUNCTION VERIFIED
Turn tester power OFF. Remove acceptor from changer. Block the coin change high tube sensors by completely filling tubes with coins or by inserting a rolled up tube of paper into the three coin tubes. Replace acceptor, turn tester power switch on and insert (1) nickel, (1) dime and (1) quarter	Upon power up, the digital display and tube sensors upper and lower LED's sequence. Coins are accepted and directed to cash box, digital display will read b.05, b.10, b.25 respectively and tube sensors upper and lower LED's will illuminate	High Tube Sensor
Insert (1) \$ coin	\$ coin is rejected	No \$ accept switch
Insert a Canadian nickel, dime	Coin is rejected	U.S. coins only or quarter coin switch
Set changer coin control option switches as follows: #1: (ON) Not Used. #2: (ON) Lo \$.25 Change tube #3: (ON) \$ coin accept Actuate changer reset switch	Digital display will read rSt	
Insert (1) \$ coin	Coin is accepted and directed to cash box, the digital display will read b1.00	
Block the middle \$.25 change tube tube sensor without blocking the high tube sensor by partially filling \$.25 change tube with coins (approx. \$5.00) or by inserting a rolled up tube of paper far enough into \$.25 change tube past the high sensor but far enough into tube to block the middle sensor. Insert (1) quarter.	Quarter is accepted and directed to the cash box. The digital display will read b.25 and the upper and lower tube sensor LED's will illuminate	Middle \$.25 tube sensor

Section 5: Bench Check Procedure

PROCEDURE	RESULT	FUNCTION VERIFIED
Actuate changer coin return lever	Digital display will read ESC	Escrow return
Manually operate each of the changer's "Inventory" switches until all coins are dispensed. P.10, P.25 respectively.	Each dispensing solenoid will energize, dispensing a coin, digital display will read P.05, <i>NOTE: If lower tube sensors are covered, the lower tube sensor LED will illuminate, if both upper and lower tube sensors are blocked, both upper and lower tube sensors LED's will illuminate.</i>	Manual dispense (\$.05, \$.10, \$.25)
Actuate the 5-10-25 inventory control switches	The digital display will read n, d, P respectively and number of coins payed out I.E. n 03 for 3 nickels, p 03 for 3 quarters and d 03 for 3 dimes.	Pay out

If all of these procedures can be successfully completed, the changer is operating properly. Set Coin Control Option Switches as desired. Set price(s) in vendor.

Section 5: Bench Check Procedure

TESTER ERROR CODES

The following is a list of error codes the changer tester will display via the digital display:

“CCO” - Changer Communication Error

This error occurs when the communication lines between the changer and tester are not present (changer not plugged in), broken or excessive noise exists on the line.

“NoCr” - No Credit

This error will occur if a coin is accepted, but not detected leaving the acceptor.

“tUbE” - Tube Sensor

This error exists when the changer's upper tube sensor is blocked, while the lower tube sensor is not.

NOTE: This error appears only during activity pertaining to the defective tube. I.E. during inventory or payout.

“2Ar” - Double Arrival

This error occurs if a second coin is detected within 1/2 second of the first coin accepted, or within 2 seconds if first coin was detected as a slug.

“ACPT” - Acceptor Unplugged

This error occurs when the changer does not communicate with the acceptor.

“RoCh” - ROM Check Sum

This error occurs when the changer's rom is defective.

“ROUT” - Routing Error

This error occurs if a coin passes by the wrong outlet sensor.

“CoJA” - Coin Jam Error

This error occurs when a coin is detected in the validation coil for too long a time.

“SLUG” - Non-Valid Coin Type

This message occurs when the changer does not recognize the coin.

Section 6: Troubleshooting

INTRODUCTION

The Troubleshooting Guide on the following pages is intended to help locate problems within the coin changer. If a changer cannot be repaired by following the guide, return the changer to the nearest Coinco Service Center for repair. If it is necessary to return the changer to Coinco, please accompany the changer with a brief description of the malfunction to help expedite the repair and return of the changer.

The vendor electronic controller board is in constant communication with the 9302-GX coin changer. The electronic controller board not only supplies operating voltage to the coin changer but is largely responsible for the operation and function of the coin changer. (Refer to Section 3, Figure 3.7)

Logic troubleshooting minimizes time spent in removing and replacing modules that are not defective. Some failures are caused by minor problems such as loose or faulty connections. Please check the following before replacing any parts:

- Connectors are inserted correctly.
- Connector pins are not bent or broken.
- All wires are properly secured.
- Inventory tubes are filled to their correct levels.

NOTE: The following Troubleshooting Guide is based on the fact that the tester or vendor, with which the defective changer is being tested, functions properly when used with a known good changer.

This guide is not intended to cover all failures, but to cover the most common failures.

9302-GX TROUBLESHOOTING GUIDE

<u>TROUBLE</u>	<u>POSSIBLE CAUSE</u>	<u>PROCEDURE</u>	<u>REMEDY</u>
No coin acceptance.	No power.	Make sure changer is plugged into vendor.	Plug changer into vendor.
	Acceptor.	Check power/blocker LED behind acceptor. If LED is ON, replace acceptor with good acceptor and test. If changer functions properly ...	Replace acceptor.
		If still no coin acceptance ...	Replace changer main logic board.
		If still no coin acceptance ...	Replace changer main power harness.
		If power/blocker LED is off, check to see that acceptor cable and changer power harness are properly connected to changer main logic board.	Plug acceptor cable and/or changer power harness into changer main logic board
		If still no coin acceptance ...	Replace changer main logic board.

Section 6: Troubleshooting

TROUBLE	POSSIBLE CAUSE	PROCEDURE	REMEDY
		If still no acceptance ...	Replace changer main power harness.
No coin acceptance or rejects percentage of good coins.	Coin return lever.	Make sure changer is mounted correctly and coin return lever is in proper position.	Reposition changer and/or vendor coin return lever.
	Acceptor is dirty or foreign matter in coin accept path.	Check to see that acceptor coin path is clean and free of foreign matter.	Clean acceptor and remove any foreign matter.
		If still rejects good coins ...	Replace acceptor.
		If still rejects good coins ...	Replace changer main logic board.
Accepts coins but gives no/or erratic credit.	Acceptor.	Replace acceptor with good acceptor and test. If changer functions properly ...	Replace defective acceptor.
		If still no/erratic credit ...	Replace changer main logic board.
		If still no/erratic credit ...	Replace changer main power harness.
Accepted coins always go to cash box.	Tube sensor board or acceptor.	Check the sensor board for loose or broken components. Make sure tube sensor board is properly secured to tube assembly. Check cable from sensor board for damage or improper connection.	Replace tube sensor board.
		If coin still goes to cash box, replace acceptor with good acceptor and test. If changer functions properly ...	Replace acceptor.
		If coin still goes to cash box ...	Replace changer main logic board.
Accepted coins always go to coin tubes.	Coin tube gate in open position.	Remove acceptor back cover, check solenoid for free operation ...	Replace acceptor.

Section 6: Troubleshooting

<u>TROUBLE</u>	<u>POSSIBLE CAUSE</u>	<u>PROCEDURE</u>	<u>REMEDY</u>
Accepted coins always go to coin tubes (continued).	Tube sensor board.	Replace tube sensor board with good tube sensor board and test. If changer functions properly ...	Replace tube sensor board.
		If coins still go to coin tubes ...	Replace changer main logic board.
Accepted quarters go to quarter coin tube when Lo-\$.25 switch is ON.	Quarter coin tube has less than 22 quarters.	Check to see that quarter coin tube has a minimum of 22 quarters.	Fill quarter coin tube with 22 quarters to cover Lo-\$.25 sensor.
	Tube sensor board.	Replace tube sensor board with good tube sensor and test. If changer functions properly ...	Replace tube sensor board.
Credits coins but does not escrow.	Coin return lever.	Make sure changer is mounted correctly and acceptor gate opens when vendor coin return lever is operated.	Reposition changer and/or vendor coin return lever.
		Acceptor.	Replace acceptor with good acceptor and test. If changer functions properly ...
No payout.	Payout solenoid.	Make sure solenoid wires are properly connected to changer main logic board.	Plug solenoid wires into logic board.
		If still no escrow ...	Replace changer main logic board.
No payout.	Payout solenoid.	If still no payout, replace solenoid with good solenoid and test. If changer operates properly ...	Replace defective payout solenoid.
		If still no payout ...	Replace changer main logic board.
		If still no payout ...	Replace changer main power harness.

Section 6: Troubleshooting

9302-GX Wiring Diagram

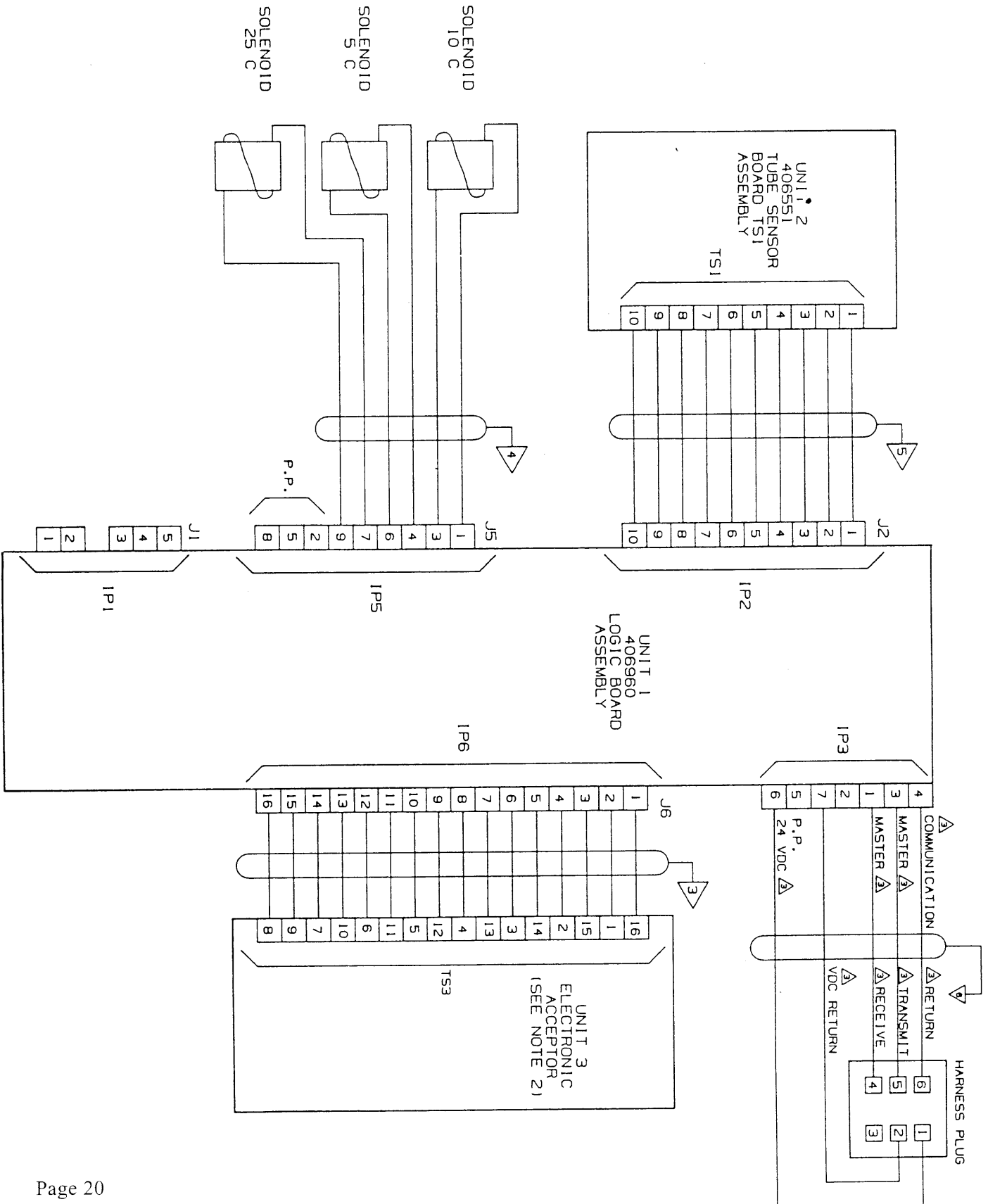

Section 7: Exploded Views

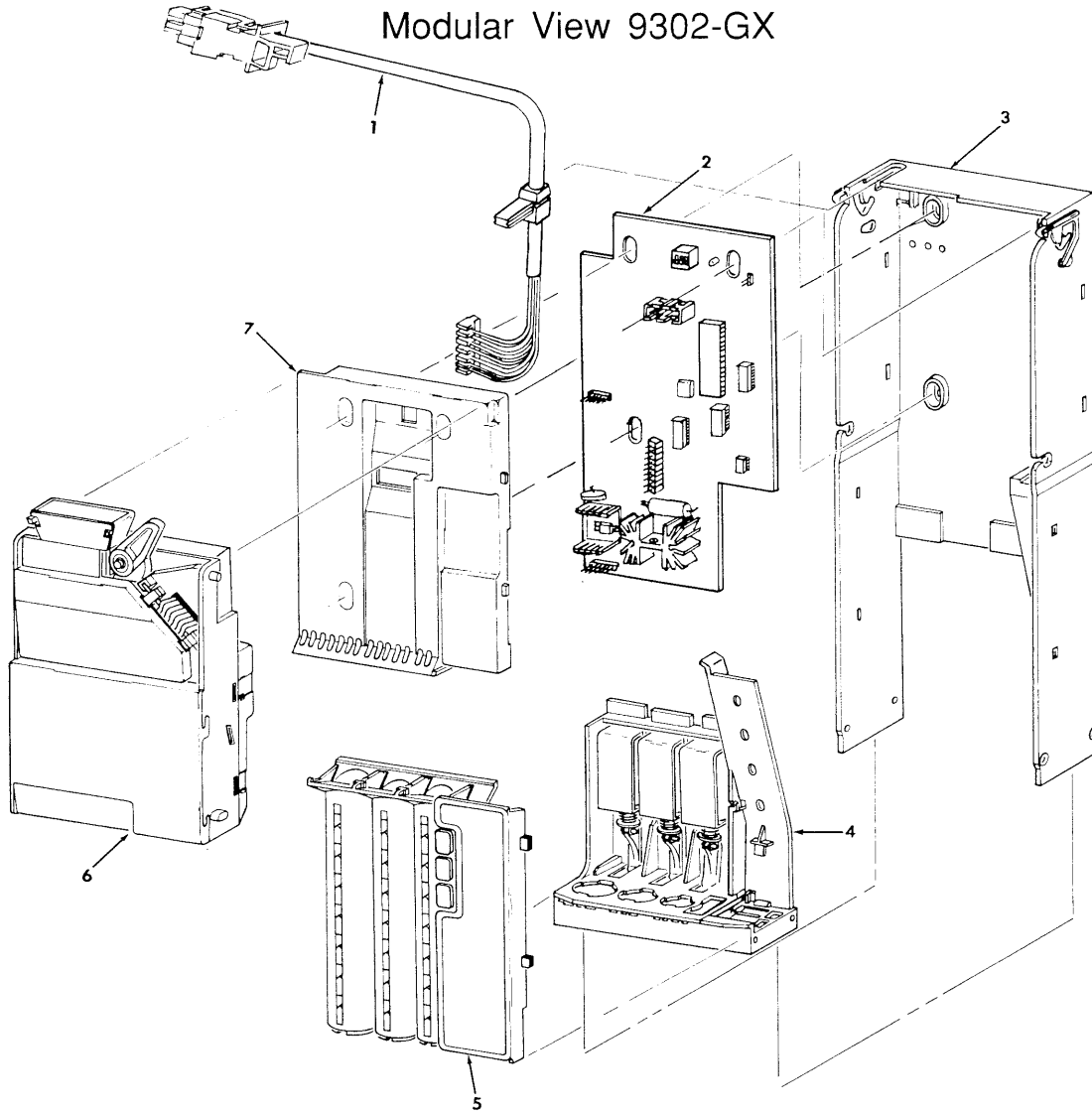

Item No.	Part No.	Description	Quantity
1	407007	Harness	1
2	407400	Logic Board	1
3	909100	Changer Housing	1
4	406739-4	Payout Assembly	1
5	406728-11	Inventory Tube Assy.	1
6	406700	Acceptor	1
7	406789	Logic Bd. Cover & Label Assy.	1

Section 7: Exploded Views

Changer Housing

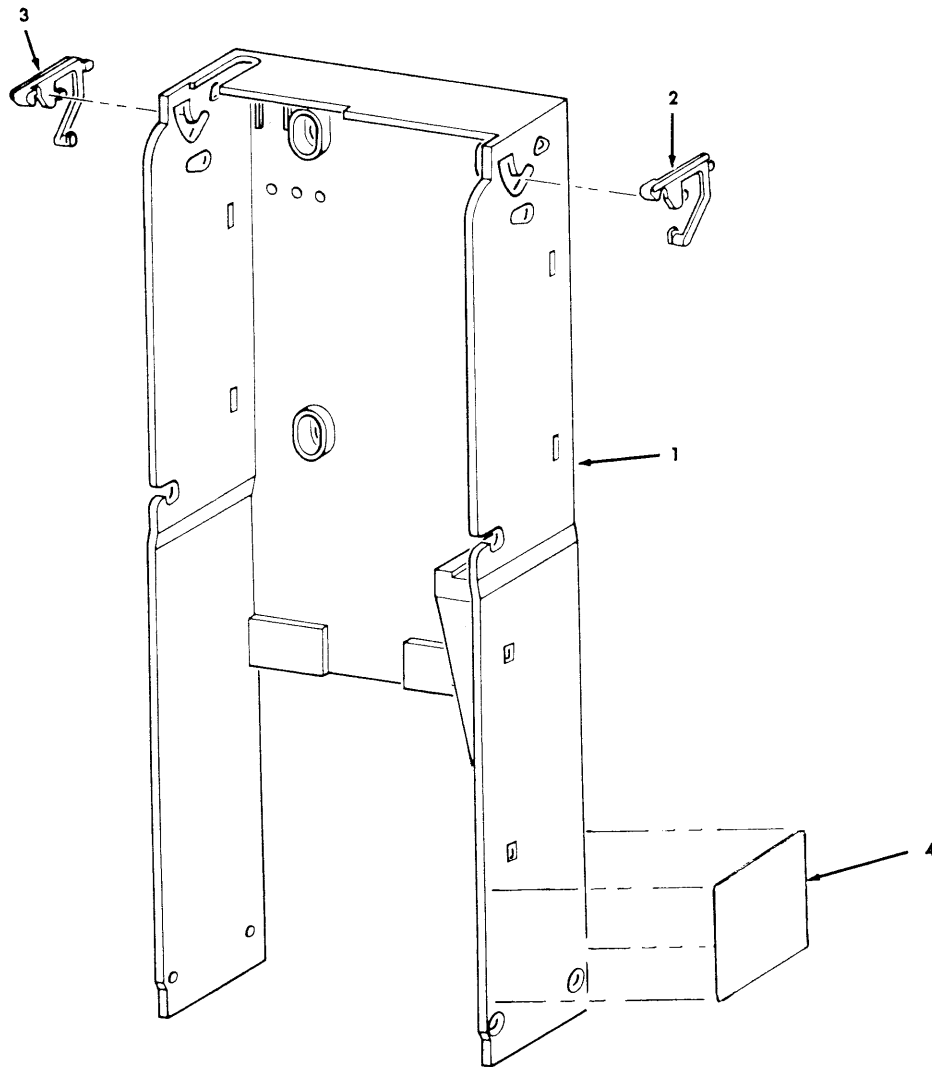

Item No.	Part No.	Description	Quantity
1	909100	Housing (only)	1
2	902011-1	Acceptor Latch, Right	1
3	902010-1	Acceptor Latch, Left	1
4	909729	Label, Ident.	1

Section 7: Exploded Views

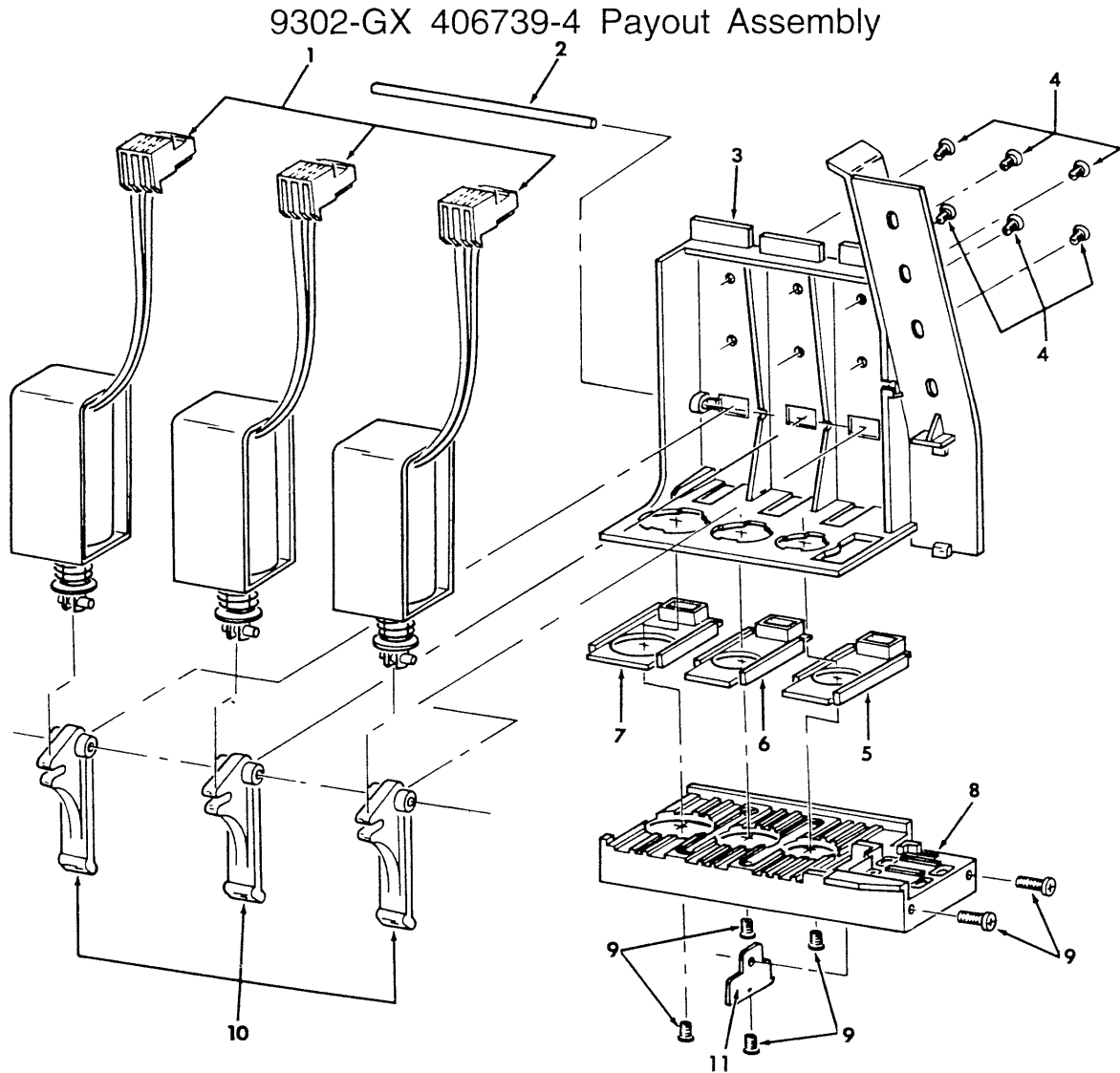

Item No.	Part No.	Description	Quantity
1	406607-4	Solenoid Assy. 24VDC	3
2	909113	Pivot Shaft	1
3	909141	Upper Payout Base	1
4	909630	Screw, 6-32x3/16	6
5	909105	10¢ Payout Slide	1
6	909104	5¢ Payout Slide	1
7	909103	25¢ Payout Slide	1
8	909102	Lower Payout Base	1
9	345P4R7	Screw, 4x7/16	8
10	909106	Solenoid Lever	3
11	909135	Coin Return Liner	1

Section 7: Exploded Views

Logic Board Cover
406789 Assembly

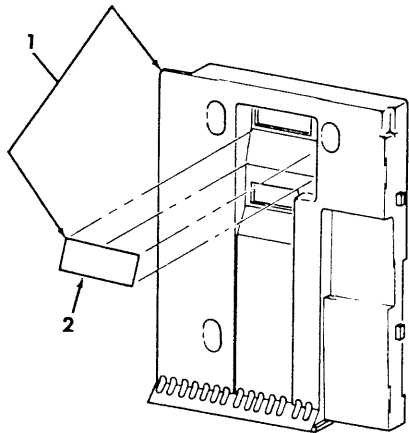

Inventory Tube
406728-11 Assembly

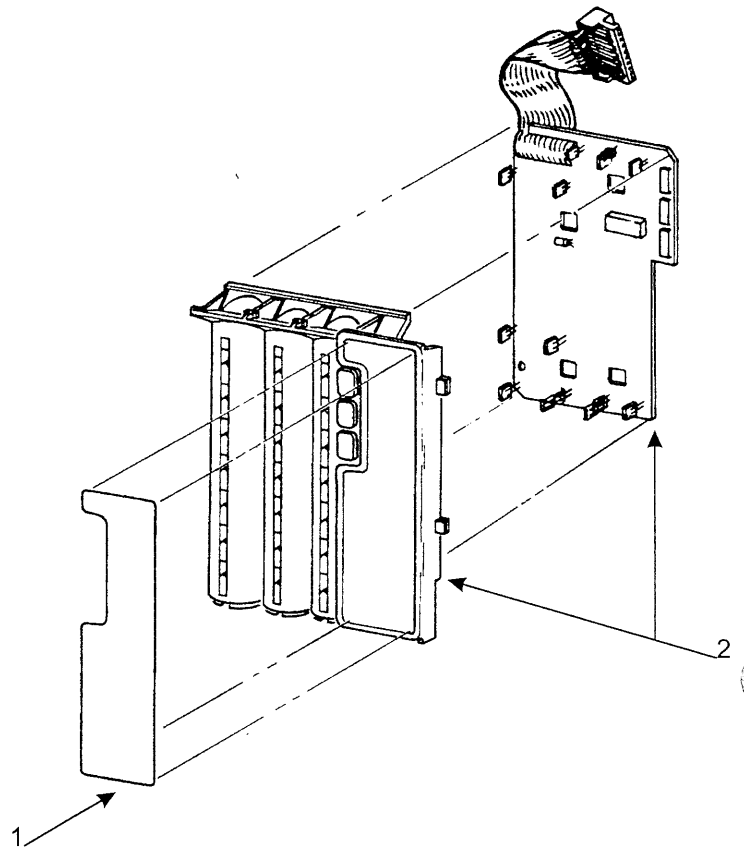

Item No.	Part No.	Description	Quantity
1	909585-3	Logic Bd. Cover	1
2	923059*	Label, Switch Options	1

Item No.	Part No.	Description	Quantity
1	921987	Inventory Tube Label	1
2	406728-10	Inventory Tube & Board Assembly	1

* Units manufactured prior to the 38th week of 1997, Item No. 2 is Part No. 909088.

Section 7: Exploded Views

Acceptor Front View
406700 Assembly

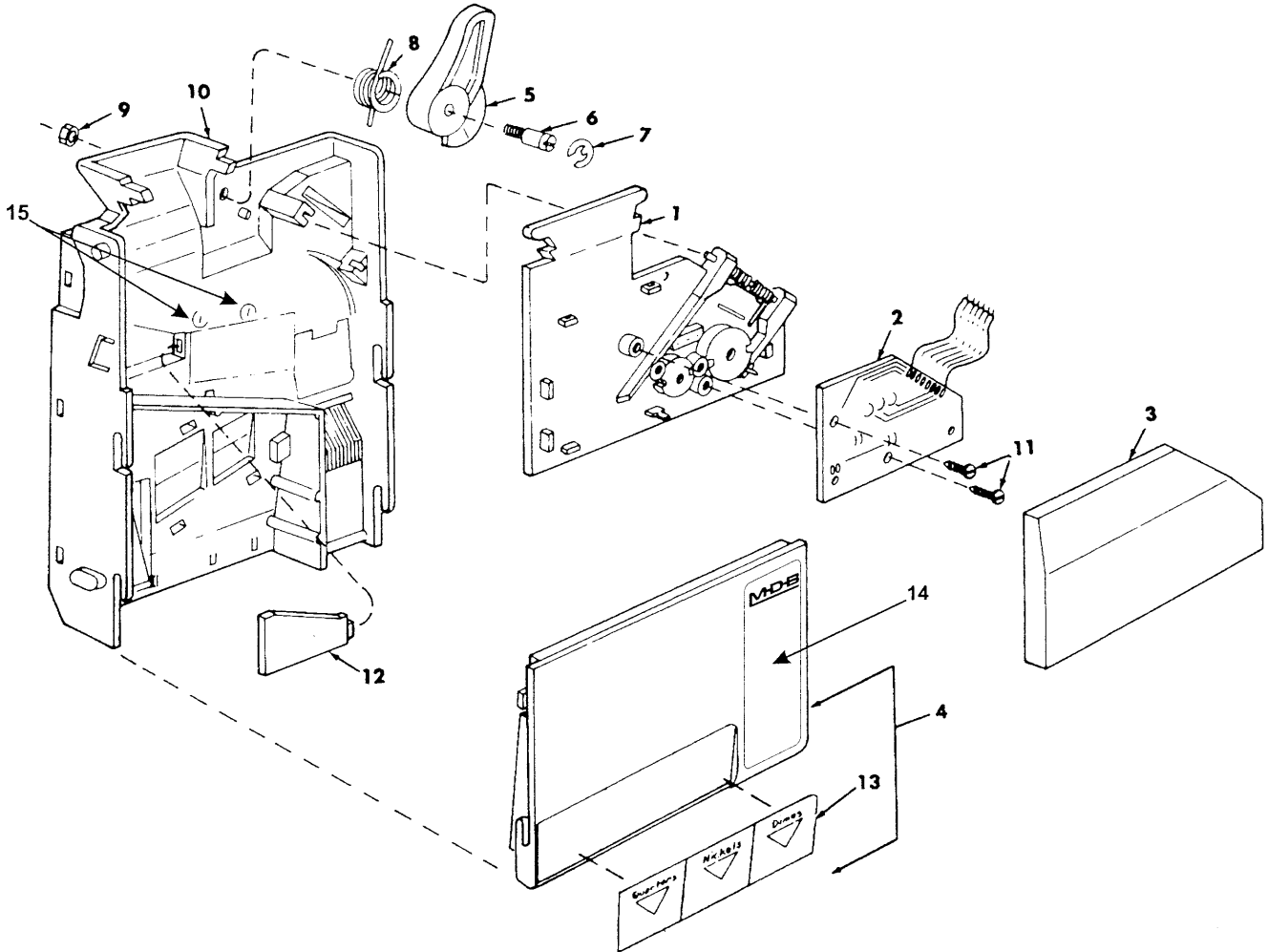

Item No.	Part No.	Description	Quantity
1	406184-2	Gate & Coil Assy.	1
2	406567	Gate Bd. Assy. LED	1
3	906596-1	Cover	1
4	406810	Front Cover Assy. (includes #13)	1
5	906606-1	Operating Lever	1
6	906624	Screw, Gate Lever Pivot	1
7	751S21X	Retaining Ring	1

Item No.	Part No.	Description	Quantity
8	906618	Spring, Oper. Lev.	1
9	400-8	Nut, 8-32 Lock	1
10	406611	Mainplate & Coil Assembly	1
11	345-4R5	Screw, 4x5/16 PH	2
12	906616	Coin Rail	1
13	909086	Front Cover Decal	1
14	921986	MDB Decal	1
15	921625	1/4" LED Labels	4

Section 7: Exploded Views

Acceptor Back View
406700 Assembly

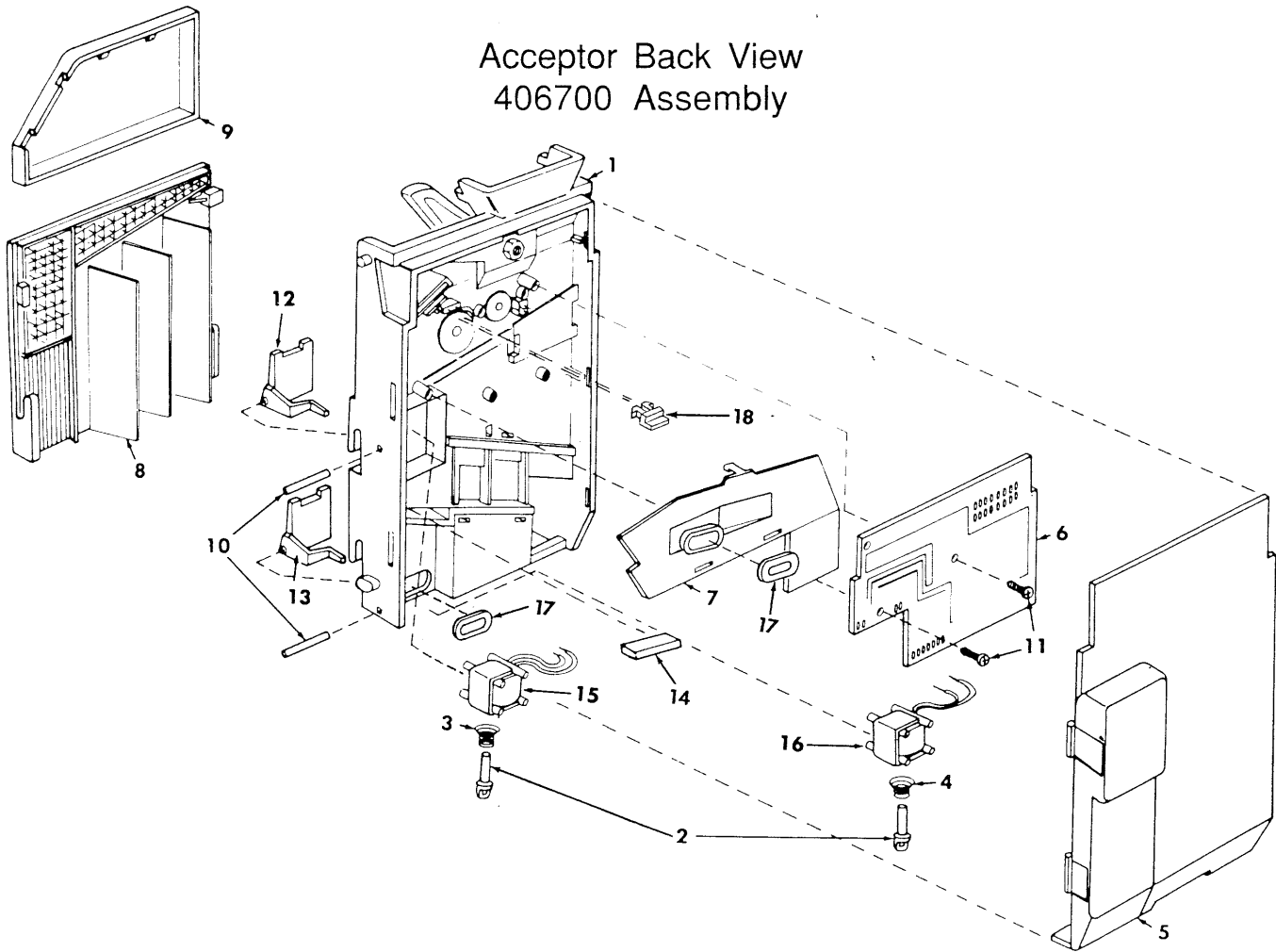

Item No.	Part No.	Description	Quantity
1	406611	Mainplate & Coils	1
2	406167	Plunger & Yoke Assembly	2
3	906619-2	Spring, Copper-plated	1
4	406619-1	Spring, Nickel-plated	1
5	909096-1	Back Cover	1
6	407506	Board Assembly 9300 Acceptor	1
7	406612	Rear Chute & Coil Assembly	1
8	406810	Front Cover	1
9	906596-1	Cover Gate	1

Item No.	Part No.	Description	Quantity
10	906622-1	Pin, Diverter Pivot	2
11	345S4R7	Screw, 4x7/16 PH	2
12	906600-1	Diverter Door, Upper	1
13	909092	Diverter Door, Lower	1
14	909853	Coin Rail	1
15	406857-3	Coil Assembly Solenoid, Upper	1
16	406857-3	Coil Assembly Solenoid, Lower	1
17	406613	Coil Assy., Sensing	1
18	908845-1	Plug, Spring Retention	2



COIN ACCEPTORS, INC.
300 Hunter Avenue
St. Louis, MO 63124-2013
(314) 725-0100 or (800) 325-2646

Coinco Publication No. 921154 Rev. 5
1/98 Printed in the U.S.A.