

AUTOMATIC PRODUCTS international, Ltd.

OPERATING SYSTEM

PARTS MANUAL

SERVICE MANUAL

MODEL 123-123A-123B-123C

GLASSFRONT MERCHANDISER

PLEASE DO NOT
REMOVE MANUAL
FROM MACHINE

AUTOMATIC



PRODUCTS

international, Ltd.

75 WEST PLATO BOULEVARD • ST. PAUL, MINNESOTA 55107-2095

Table of Contents
Sections 1 & 2
Unpacking, Installation, Components

Section 3
Quick Set Up Guide

Table of Contents
Section 4
Advanced Set Up and Operations Guide

Section 5
Parts

Section 6
Trouble Shooting

WARRANTY	ii
INTRODUCTION	iii
HOW TO USE THIS MANUAL	iii
STANDARD FEATURES	iv
CAPACITIES	v
UNPACKING	1.01
CLEANING	1.01
INSTALLATION	1.02
OPTIONAL EQUIPMENT	1.07
Chiller	1.09
COMPONENTS	2.01
Power Supply	2.01
Lighting System	2.01
Main Product Shelves	2.01
Delivery Bin	2.01
Chilled Air Machine	2.02
Dex/UCS	2.02
Printer Support	2.02
Multi-Drop Bus	2.02
Coin Mechs	2.02
Bill Validators	2.02
Debit Cards	2.02
Vend Motors	2.03
Cabinet and Shelf Harnesses	2.03
Selection System	2.03
MasterMenu Keypad	2.04
Logic Center Board	2.05
Food Driver Board	2.05
The Front Panel Display	2.05
The Chime	2.05
Dual Zone Supplement	2.06

To achieve the most trouble-free operation from your APi 120 Series Merchandiser, it is recommended that this service manual be thoroughly read and the instructions followed pertaining to installation, servicing and maintaining of the unit.

Should you have questions pertaining to this manual or the vendor, please contact your APi distributor or write directly to:

Technical Service Dept.
Automatic Products int. Ltd.
75 West Plato Blvd.
St. Paul, MN. 55107 USA
651-224-4391
651-224-5559 (fax)

EXPRESS WARRANTY

Automatic Products international ltd. (APi) expressly warrants these automatic merchandisers (the "Unit"), manufactured by it, to be free under normal use and service from defects in material or workmanship for a period of two (2) years from the date of delivery of this Unit to the original purchaser. This warranty extends only to the original purchaser of the Unit. The exclusive remedy for this warranty is limited to the repair or replacement, at APi's sole option, of any part or parts of the Unit that are returned to APi or to the authorized dealer or distributor of APi from whom the unit was purchased with all transportation charges prepaid, and which, on APi's examination, shall, conclusively appear to have been defective. This warranty does not:

- a. extend to any Unit, or part thereof, that was subjected to misuse, neglect, or accident by other than APi after its delivery to the original purchaser;
- b. extend to any Unit, or part thereof, that was modified, altered, incorrectly wired or improperly installed by anyone other than APi or used in violation of the instructions provided by APi;
- c. extend to a Unit which has been repaired or altered by anyone other than APi or authorized dealer/distributor;
- d. extend to a Unit which has had the serial number removed, defaced or otherwise altered;
- e. extend to plastic or glass windows, lamps, fluorescent tubes and water contact parts;
- f. extend to any unit used outdoors;
- g. extend to accessories used with the Unit that were manufactured by some person or entity other than APi.

APi DISCLAIMS ALL OTHER WARRANTIES OF ANY KIND AS TO THE UNIT AND ALL WARRANTIES OF ANY KIND AS TO ANY ACCESSORIES. THIS DISCLAIMER OF WARRANTIES INCLUDES ANY EXPRESS WARRANTIES OTHER THAN THE LIMITED WARRANTY PROVIDED ABOVE AS TO THE UNIT AND ALL IMPLIED WARRANTIES OF MERCHANTABILITY AND FITNESS FOR A PARTICULAR PURPOSE AS TO THE UNIT AND ANY ACCESSORIES. UNDER NO CIRCUMSTANCES SHALL APi BE RESPONSIBLE FOR ANY INCIDENTAL, CONSEQUENTIAL OR SPECIAL DAMAGES, LOSSES OR EXPENSES ARISING FROM OR IN CONNECTION WITH THE USE OF, OR THE INABILITY TO USE, THE GOODS FOR ANY PURPOSE WHATSOEVER. No representative of APi or any other person is authorized to assume for APi, or agree to on behalf of APi, any other liability or warranty in connection with the sale of this unit.

APi reserves the right to make any changes or improvements in its products without notice and without obligation, and without being required to make corresponding changes or improvements in Unit theretofore manufactured or sold.



75 West Plato Boulevard
St. Paul, MN 55107

features of the APi 120 snack merchandiser

STANDARD FEATURES

- Up to 80 selections.
- Multi drop buss capabilities.
- Extensive diagnostics capabilities.
- Friendly text based interface.
- Configuration upload and download capabilities.
- User programmable function keys.
- Flexible spiral spacing for large products.
- Eight point star drive motor.
- Four security levels.
- Six languages.
- Machine reset capability.
- Real time clock.
- Personal computer interface.
- Printer interface.
- Chime.

PRICING

- Global pricing by machine or by shelf.
- Extensive discounting capabilities.
- Shutdown capabilities.
- Combo vends.
- Product codes.
- Programmable spiral count.
- Upload and download capabilities for pricing and set up.
- Programmable maximum payout.
- Extensive accountability, including all discounts and free vends.

SCROLLING DISPLAY

- User friendly scrolling display to help with the selection process and provide customer feedback.
- User programmable point of sale and operational messages.
- 20 character display.

OPTIONS

- Point of sale window.
- Delivery bin cushion.
- Base kit.
- Lexan window.
- MasterMenu™ online software.
- Transportable memory unit.

NOISE LEVEL

Operates at less than 70 db (A).

ACCEPTABLE AMBIENT OPERATING TEMPERATURE RANGE

All equipment manufactured by Automatic Products Intl. Ltd. is designed to work properly in a temperature range of 10°C to 38°C (50°F to 100°F) in still air (75% R.H. non-condensing). The machine is capable of being stored in a temperature range of -18°C to 68°C (0°F to 155°F).

Specifications	123 Domestic Ambient	123 Domestic Chilled	123 Export Ambient	123 Export Chilled
Height	72"/183 cm	72"/183 cm	72"/183 cm	72"/183 cm
Width	38.875"/99 cm	38.875"/99 cm	38.875"/99 cm	38.875"/99 cm
Depth	35"/89 cm	35"/89 cm	35"/89 cm	35"/89 cm
Floor Space	9.5 sq. Ft./ .88 Sq. Meter	9.5 sq. Ft./ .88 Sq. Meter	9.5 sq. Ft./ .88 Sq. Meter	9.5 sq. Ft./ .88 Sq. Meter
Container Size	72.5 Cu Ft./ 2.05 Cu Meter	72.5 Cu Ft./ 2.05 Cu Meter	72.5 Cu Ft./ 2.05 Cu Meter	72.5 Cu Ft./ 2.05 Cu Meter
Voltage (AC)	120V	120V	230V	230V
Hertz	60Hz	60Hz	50Hz	50Hz
Standby Amperes	0.7A	0.7A	.35A	.35A
Running Amperes	3A	12A	1.5A	6A
Watts	360W	1440W	345W	1380W
Refrigerant Type	N/A	134A	N/A	134A
Refrigerant Charge	N/A	8.4 oz/0.24 Kg	N/A	9.0 oz/0.25 Kg
High Side Test Pressure	N/A	440 psi	N/A	440 psi
Low Side Test Pressure	N/A	162 psi	N/A	162 psi
Shipping Weight	600 lbs/272 kg	700 lbs/318 kg	600 lbs/272 kg	700 lbs/318 kg

Unless otherwise specified machine will be shipped with spiral assortment shown below.
 Figures in circles represent capacities each spiral.

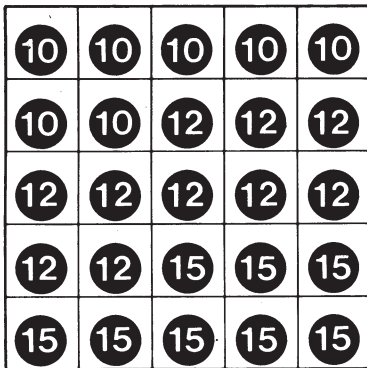

Model 123-525
 Capacity as shown: 310 units.

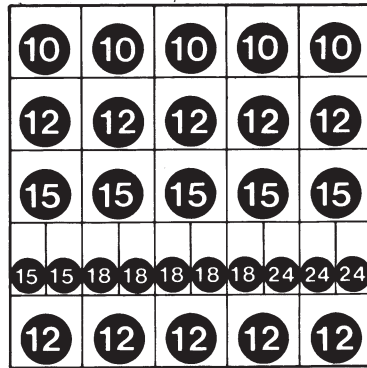

Model 123-530
 Capacity as shown: 437 units.

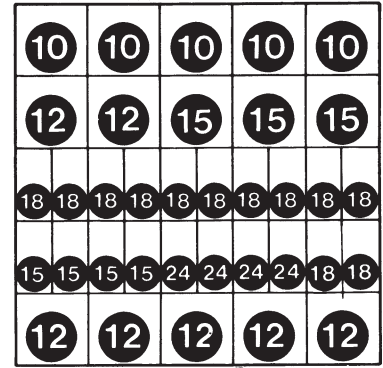

Model 123-535
 Capacity as shown: 551 units.

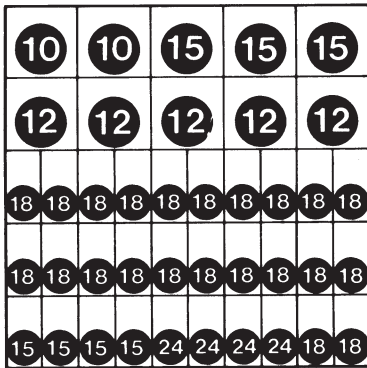

Model 123-540
 Capacity as shown: 677 units.

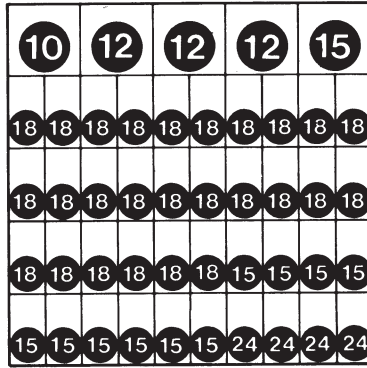

Model 123-545
 Capacity as shown: 775 units.

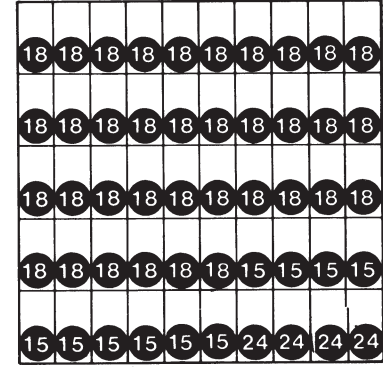

Model 123-550
 Capacity as shown: 894 units.

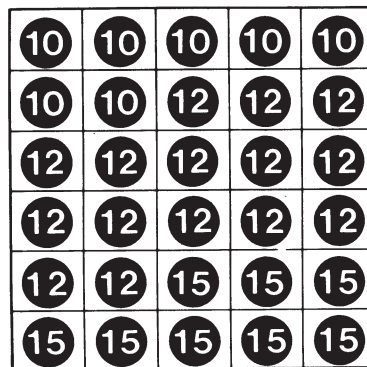

Model 123-630
 Capacity as shown: 370 units.

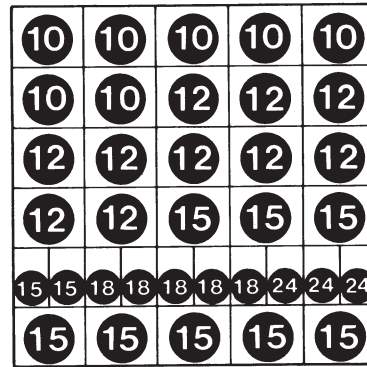

Model 123-635
 Capacity as shown: 502 units.

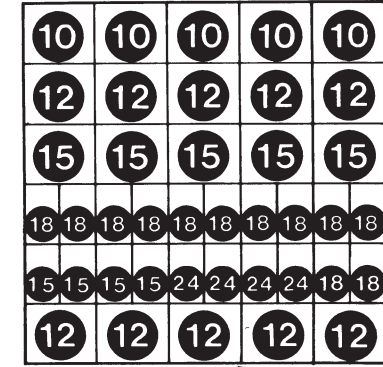

Model 123-640
 Capacity as shown: 617 units.

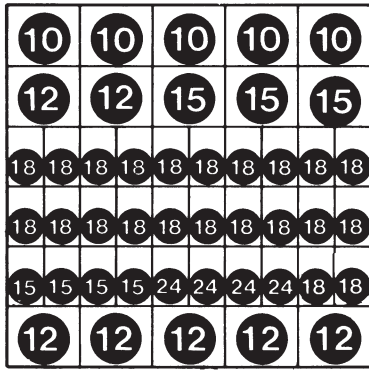

Model 123-645
Capacity as shown: 731 units.

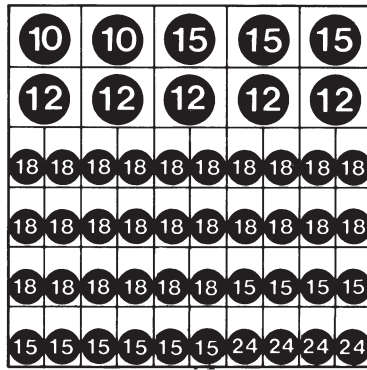

Model 123-650
Capacity as shown: 839 units.

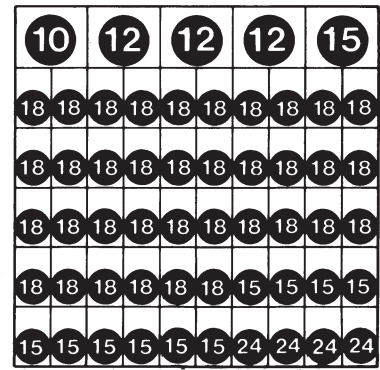

Model 123-655
Capacity as shown: 955 units.

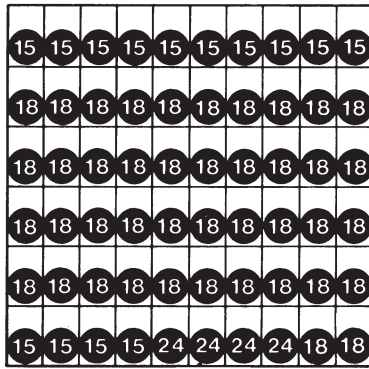

Model 123-660
Capacity as shown: 1062 units.

SPECIFICATIONS

- HEIGHT - 72" WIDTH - 38-7/8" DEPTH - 35
- FLOOR SPACE REQUIRED - 9.5 SQ. FT.
- SHIPING CONTAINER SIZE - 72.5 CU. FT.
- POWER REQUIREMENTS - 115 V., 60 HZ.
- STANDBY AMPERS - .7 OPERATING
- AMPERES - 3
- CHILLED MACHINES - USE 11OZ OF 134A REFRIGERANT

PRODUCT SIZE CAPABILITY

SHELVES	HEIGHT	WIDTH of Snack Shelves Only	WIDTH of Candy Shelves Only	DEPTH OF Snack Spirals Only Choice:	DEPTH OF Candy Spirals Only Choice:
Top	7-3/4"	2 1/2" to 5 1/4"	1" to 2 1/4"	6 — Item Spiral 3-3/32"	6 — Item Spiral 2-7/8"
Second	7-1/4"	2 1/2" to 5 1/4"	1" to 2 1/4"	7 — Item Spiral 2-21/32"	7 — Item Spiral 2-1/2"
Third	6-5/8"	2 1/2" to 5 1/4"	1" to 2 1/4"	10 — Item Spiral 1-7/8"	9 — Item Spiral 1-15/16"
Fourth	7-1/4"	2 1/2" to 5 1/4"	1" to 2 1/4"	12 — Item Spiral 1-9/16"	10 — Item Spiral 1-3/4"
Fifth	6-3/4"	2 1/2" to 5 1/4"	1" to 2 1/4"	15 — Item Spiral 1-7/32"	12 — Item Spiral 1-1/2"
Sixth	6-1/4"	2 1/2" to 5 1/4"	1" to 2 1/4"	18 — Item Spiral 1"	15 — Item Spiral 1-1/8"
				30 — Item Spiral 1/2"	18 — Item Spiral 15/16"
				40 — Item Spiral 5/16"	24 — Item Spiral 11/16"
					30 — Item Spiral 1/2"
					40 — Item Spiral 3/16"

Ten selection shelves for candy and other narrow items fit on all six positions.

Spiral of one item capacity can be freely interchanged with any other of the same diameter.

Boxed items may need slightly larger clearances to vend properly.

Movable spacers available to adjust widths to ranges shown in each selection.

Gum-and-Mint Capacity. It is difficult to determine the true capacity due to variations of product size. The average capacity for the Gum-and-Mint Shelf is 170 items.

The Snackshop 123 is assembled and packed so that a minimum amount of time is necessary for preparation to install it on location. The following steps are recommended to insure correct unpacking.

1. **Shipping Damage:** Thoroughly inspect the exterior of the carton for damage which may have occurred during shipment. Report any damage to delivering carrier and follow their instructions.
2. Remove staples from lower edge and those at top of carton, and slit carton vertically at the taped corner. Open and remove carton. Remove the remainder of the packing material. On machines shipped with lock in place, the keys are taped inside the coin return.
3. **Remove Vendor with a Forklift Truck:** Remove the carton from the vendor. From the front of the vendor tip the vendor backward and run forks under the cabinet.
4. **Removing Vendor Without a Forklift Truck:** Remove the carton from the vendor. Break off the thin piece of board behind the rear legs. From the front of the machine tip the vendor back enough to clear the lower legs from the holes in the front board. Push the machine back off the base. Remove the pallet.

NOTE: Because the weight concentration is toward the back of the cabinet, trucking and lifting should be done from the back. CAUTION should be taken when trucking from side.
5. On machines with lock in place, unlock, and turn handle to open door. When no lock is furnished, remove clip and turn handle. Swing door to its full open position.
6. Remove all packing tape and paper from various areas of machine and the shipping strap.
7. **Warranty:** The warranty card is attached to the cover of this manual. It must be filled out in full and mailed at once to insure coverage.

◆ **IMPORTANT:** A set of anchoring brackets are sent with each machine. The kit is located in the bottom of the machine complete with instructions. It is recommended that this kit be installed to prevent shifting of the machine.

CLEANING

The Snackshop 120 series will do the best merchandising job for you if it is kept clean. The display window can be cleaned with any good glass cleaner. The exterior and interior surfaces should be cleaned with warm water and mild detergent. Rinse thoroughly and dry all surfaces.

CAUTION: Do not use any cleaners containing silicon as this could cause electrical failures.

The main product shelves can be best cleaned with the spirals and product spacers removed. Refer to page 1.03 for removal of spirals and removal of the product spacers.

Clean the acceptor on the coin mechanism frequently as accumulated dirt in this area can cause coins to hang or not be accepted. Follow recommended cleaning procedures as described by the manufacturer.

installation

Leveling the Machine: on location is important for the proper function of the machine. The four leveling screws in the legs are the means of leveling the machine. After positioning the machine, level machine in front to rear and right to left directions. After leveling, turn front right (lock side) leveling screw in about one-half turn to drop this corner slightly to make the door easier to close and lock.



CAUTION: THIS MACHINE IS DESIGNED FOR INDOOR USAGE ONLY. ANY OTHER USAGE MAY VOID THE MANUFACTURERS WARRANTY.



CAUTION: THE FOLLOWING PROCEDURE REQUIRES THAT THE MACHINE HAVE POWER APPLIED AND A POTENTIAL ELECTRICAL SHOCK HAZARD EXISTS.



Voltage and Polarity Check

It is important that this machine is hooked up to the proper voltage and polarity. Using a voltmeter, perform the following checks from the illustration below.

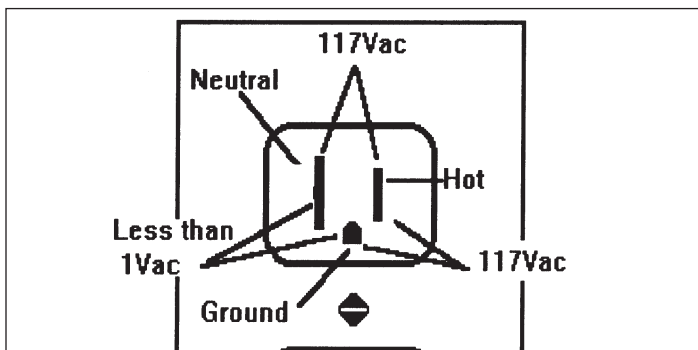

NOTE: Should the readings be different from above, have a certified electrician correct the problem.

Loading Snack Shelves

Open door to full open position, push down on plastic lock lever (Figure 1.1) on both sides of shelf to unlock shelf, holding lever down. Grasp the shelf, under both front corners (see Figure 1.1), lift front shelf slightly and pull forward until shelf reaches its stop. The shelves tilt down (do not drop) to make loading easier. Only one product shelf should be in the loading position at a time. When returning a shelf, be sure the shelf is in its full home or vend position. Begin loading with the top shelf. Move it to the loading position. The height spacing for items is greatest in this shelf and the tallest bagged items should be placed there. Soft items, such as pastry, pies, etc., should be placed in the lowest snack shelf, making the drop distance as short as possible.

◆ **IMPORTANT:** Product must not be forced into the spiral spaces but should fit freely. If the product is too tight, use a larger pitch spiral. The bottom of the product should be placed on top of the spiral wire that rests on the shelf surface (see Figure 1.2). The width of the product must be greater than the diameter of the snack spiral. If it is smaller, the product may fall through when it is in the front, ready to vend position.

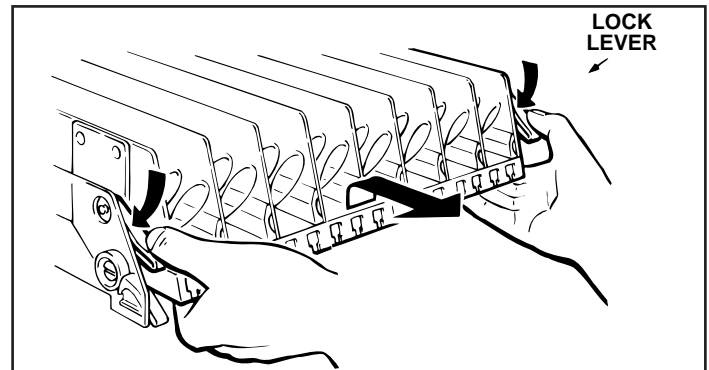

Figure 1.1: Moving shelf to loading position.

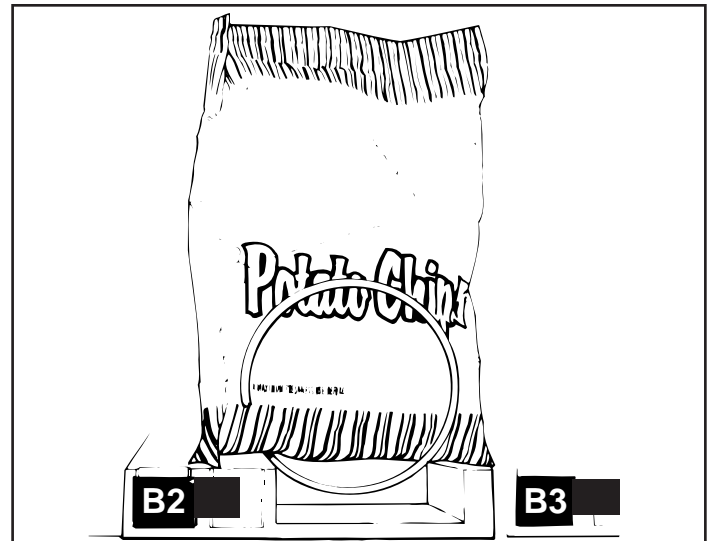

Figure 1.2: Placement of product on main product snack shelves and front end position of spiral.

Adjusting the Stopping Position of the Spiral.

One primary difference that distinguishes the new motors from previous motors is the presence of an eight sided star at the drive hub of the motor. This permits the stopping position of the spiral to be customized by the operator to ensure the best possible delivery of product. To change the stopping position of the spiral, remove the spiral lock from the motor by pinching the shaft of the spiral lock from the back side of the motor and pulling forward on the front side of the spiral lock. The spiral lock can be reinstalled in any of eight different positions by turning the spiral lock to the position desired and pushing the shaft of the spiral lock through the eight sided star at the drive hub of the motor.

Removal of Spiral

Grasp the front of the spiral and turn it clockwise. Lift the spiral up and off of the spiral lock. When replacing a spiral attach it around the tab on the spiral lock and turn the spiral counterclockwise to lock it in place. Be sure the front end of the spiral is positioned properly (with the front end if the spiral pointing downward on the left side) (see Figure 1.3). Give a light forward pull on front of the spiral to check it is locked in place.

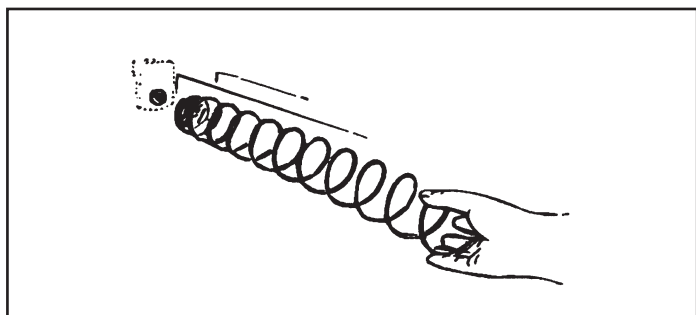

Figure 1.3: Removing and installing spiral.

Product Spacers-5 Selection Shelf

A product spacer is used to reduce the width of the product area and should be used on any 5-selection snack shelf where the product width is 4 1/2" or less. Spacers should fit within 1/8" of the product but should not fit tight against the product. There are four positions in each snack space where these spacers can be placed. To install the spacer, align the lock ears (on the lower edge of the spacer) with one of the three sets of slot (one front and one rear). (See Figure 1.4). Push the spacer to the rear to allow the ears to enter the slots, then allow the spacer to move forward. Be sure the ears are in the same set of slots, front and rear. (See Figure 1.4). Continue loading all spirals adjust with spacers where needed in the top shelf. Return the top shelf to the vend position and following this procedure load the remainder of the large spiral shelves. The shelf divider separating the right (lock side) column from the next column is movable to allow

vending of products wider than 5 1/2" in the second column. If this is used the right column must be used to vend a narrower product.

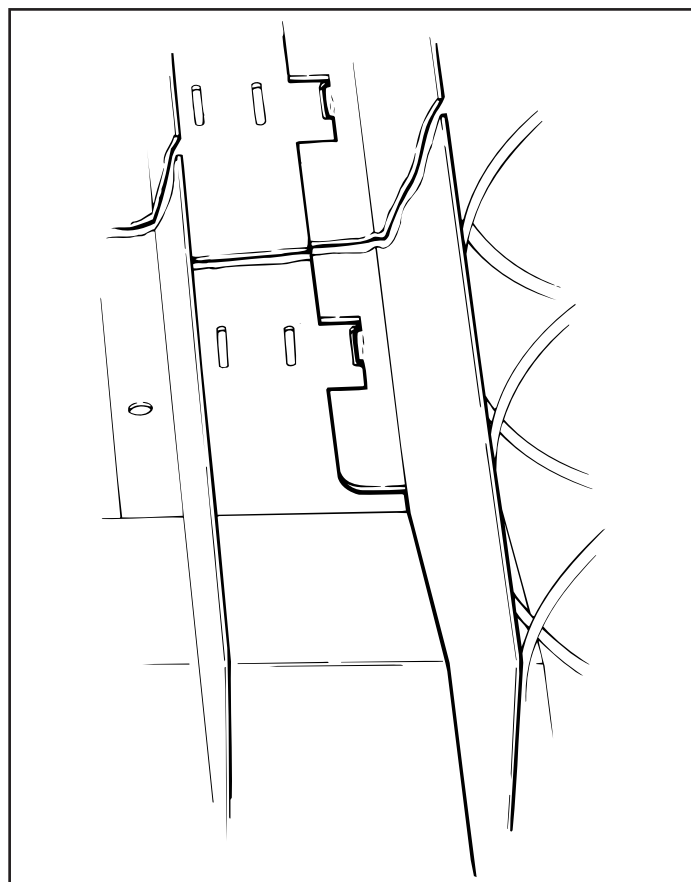

Figure 1.4: Alignment of movable product spacers.

installation

Loading Main Product Candy Shelves

The 10-selection (candy type) shelves are loaded similar to the 5-selection shelves except that the bottom of the product sits on the shelf in front of the spiral wire (see Figure 1.5) that rests on the shelf. These products must also fit properly product in the spiral space; do not force product into spiral.

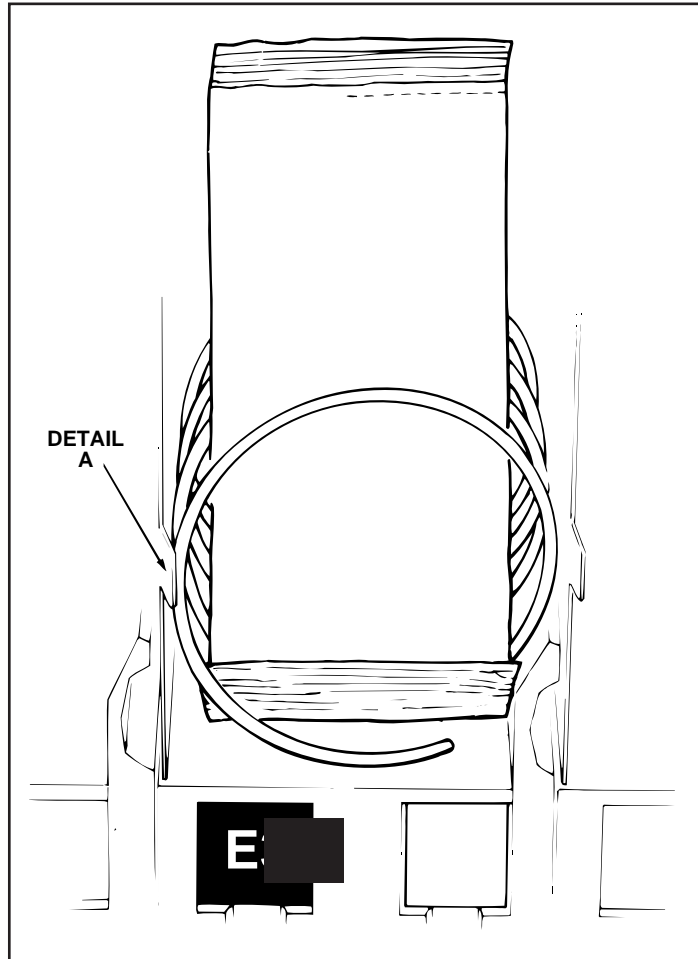

Figure 1.5: Placement of product on main product candy shelves and front end position of spiral.

These spirals are removed and installed the same as the large spiral (see Figure 3), except that the front end position is different (approximately 5 o'clock)(see Figure 1.5) and the front left side of the spiral must be behind the small tab located on the left side of the product space side wall (see Figure 1.5, Detail A).

Product Spacers-10 Selection Shelf

The 10-selection shelves are equipped with a product spacer (see Figure 1.6) that can be pivoted from the right side of every other product space. These spacers should be pivoted out to hold the product upright, but not tight against the product. Leave about 1/8" clearance between the spacer and the product.

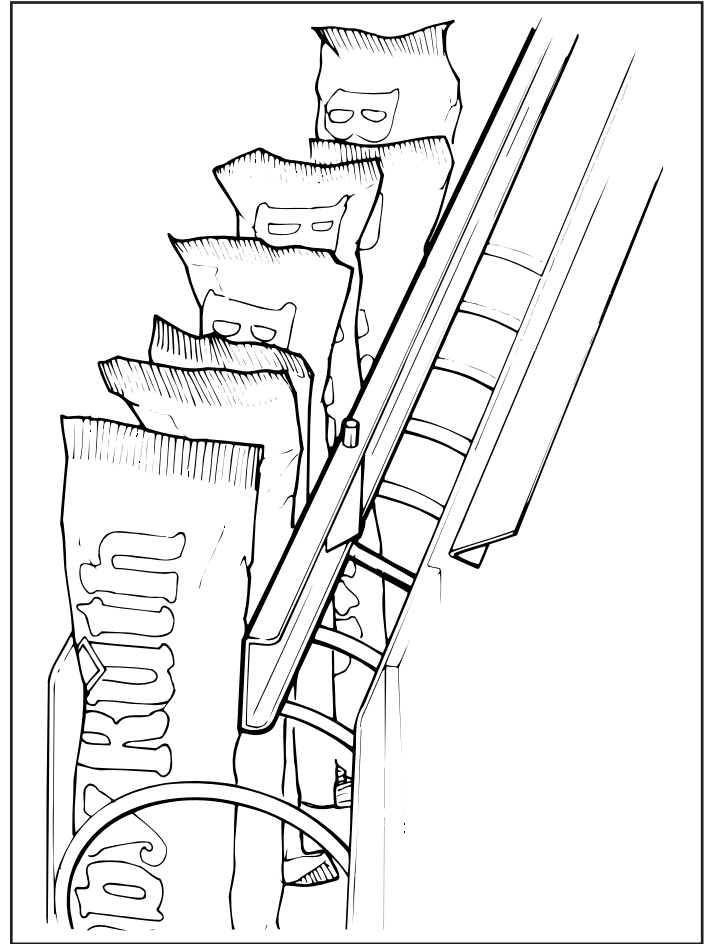

Figure 1.6: 10 selection shelf product spacer positioned to hold candy upright.

Product Pushers

Included with the machine is enough pushers for you to install a pusher on each candy spiral. This plastic part is designed to push the top of the product forward while it is vending, helping it fall from the shelf. It can also be used with products that have the wrapper end flap on the outside of the package. In this case, the pusher prevents these products from hanging on the spiral by spreading the flap. The pusher is installed approximately 210 degrees from the front end of the spiral with the tab extending forward (see Figure 1.7). Locate the pusher in its proper position, hold it against the spiral wire and push the semi-circular part around the spiral wire. Note: Not every selection spiral will need a product pusher. (Example - Box Items.)

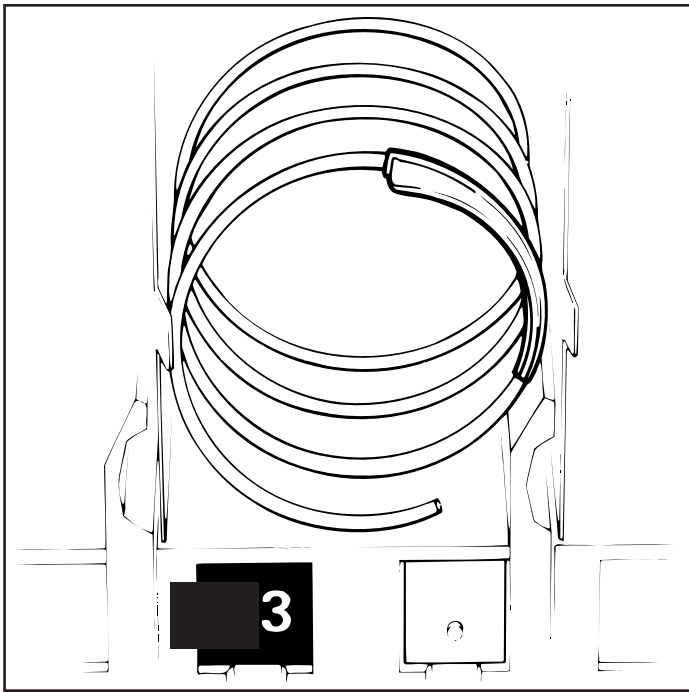

Figure 1.7: Location of product pusher on spiral.

Bagged or Boxed Items: In the 10-selection shelves if not loaded properly could be a problem. The sealed edge of the bag may get under the spiral wire causing the product to hang up after it has been vended. It is recommended that the lower edge of these types of product be folded forward and up (see Figure 8) next to the product before inserting into the spiral space. It is also recommended to use an 18 count spiral for bagged items because of the product setting to the bottom of the package.

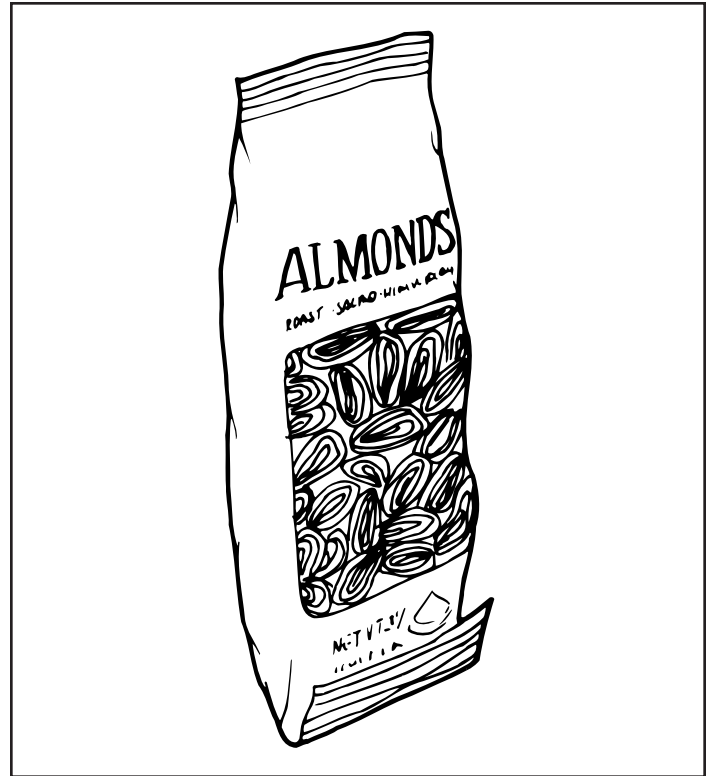

Figure 1.8: Fold bagged items bottom edge forward and up.

CIGARETTE VENDING FROM THE APi 123.

Cigarettes can be vended from the candy shelves using the (15 capacity) spiral for the soft pack regular, king, 100 MM or 120 MM packs. the (12 capacity) spiral should be used for (box) packs.

LOCK PRODUCT SHELVES. After all the product has been loaded be sure all shelves are returned to their vend position behind the front roller guide.

INSTALL PROPER PRICE TABS into price tab holder for each selection in the main product area. (See Figure 1.9)

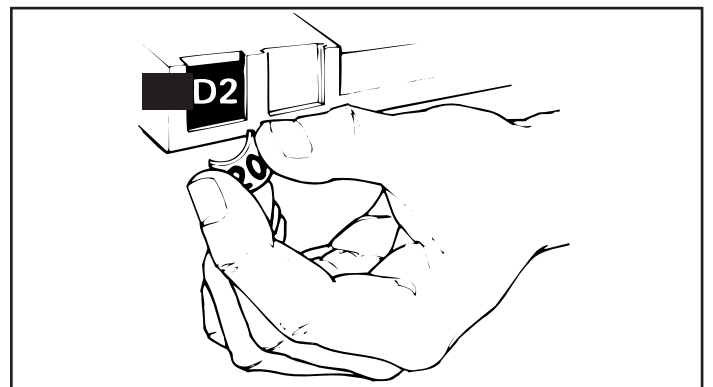

Figure 1.9: Installing price tabs.

Loading Gum and Mints:

The Gum and Mint shelf is located below the lowest Snack Shelf (optional). Unlatch the shelf by pulling forward the two metal latches located to the right and left of the shelf and pull forward. The cover can be pushed back to the rear for easy loading. The shelf contains four individual selections.

The first selection on the left contains two fillers for use with thin mints. (Roloids - Certs, etc.). These fillers can be removed for standard gum or mints.

The two selections on the right of the Gum and Mint shelf also have fillers. These selections can be used for standard size gum and mints or the fillers may be removed for larger gum and mint products.

Each selection has a display hinge assembly which should be adjusted after the shelf is loaded. To adjust the display hinge, loosen the wing nut and slide the spring hinge of the flipper over the second product and fasten tightly.

◆ Be sure to close the cover on the gum and mint shelf before pushing the shelf back to its home position.

◆ The gum and mint shelf can be used as a loading platform while filling the machine. The maximum load of the gum and mint shelf is 35 pounds.



Connecting a 320 to a 120 Series Snack.

A 320 machine can also be controlled by a 120 Series snack merchandiser in lieu of a Control module. The following is a list of steps required to connect a 320 (AL A CARTE) machine to a 120 series snack machine.

1. Locate the interconnect harness coming out of the back side of the food cabinet and route it into the back side of the snack (remove the triangular plate just above the line cord) to the LogiCenter board and plug into the P8 connector. (Bottom Right)
2. The 320 machine is considered Cabinet 2 when connected to a 120. Make sure the Jumper on the Food Driver Board (FDB) is set to cabinet 2.
3. Set the Temperature Control jumper on the FDB to the appropriate temperature setting. R for a refrigerated machine, F for a frozen machine. NOTE: This jumper is only a default setting, if for any reason the snack machine loses communications with the food/frozen machine this setting takes over.
4. All programming for the 320 (cabinet 2) is done in the snack machine. The following items must be programmed for the 320 machine to operate correctly:
 - A. Set Motor Pairs by pressing and holding down the * key while pressing F1 on the MasterMenu keypad.
 - B. Set Temperature for Cabinet 2 by pressing and holding down the * key while pressing F2 on the MasterMenu keypad.
 - C. Set Prices by pressing F4 on the MasterMenu keypad.

NOTE: All selections in the 320 will start with the number 2 and all selections in the snack will start with the number 1. The item tabs on the 320 are reversible.

For Detailed information on setting up a 320 (A LA Carte) merchandiser, please refer to the 320 Service Manual paying special attention to the two blue pages in the middle of the book with the heading "Quick Set up Reference".

MasterMenu Online Software

MasterMenu Online software gives you the capability of completely setting up any 120 Series Snack merchandiser, 310 Control Module, 320 food merchandiser, or 223 Hot beverage merchandiser machine on your personal computer (PC). MasterMenu Online also has the ability to load complete new logic board software revisions to a machine. To load complete new software into a machine the PC must be connected directly to the machine logic board via a cable P/N 56800022 and the DEX/UCS harness P/N 680509. These updates can be sent to you via e-mail or as a file on a floppy disk.

MasterMenu Online Installation

Personal Computer Requirements

To install MasterMenu Online, you need:

- Personal or Multimedia computer with a 486 or higher processor.
- Microsoft Windows 95 operating system or later.
- 16 MB of Ram.
- 5 MB of hard disk required.
- VGA or higher resolution video adapter.
- Microsoft Mouse or Compatible pointing device.
- 3.5 inch floppy drive

CHIP

Two pieces are required to use **CHIP**, the touch memory button (**CHIP**) and an Upload/download Harness that allows **Chip** to communicate with the machine.

Touch Memory Button (Pn 17500003)

The Touch Memory Button (**CHIP**) can be used to download to or upload from any 310 Control Module or API 20 Series machine. **CHIP** is capable of storing all settable data from a machine, with the exception of the time and date. Once **CHIP** is programed you can take it to as many machines as you wish to upload the information stored in **CHIP**. **CHIP** can be overwritten and reused as many times as desired. **CHIP** is mounted on a key chain holder. **CHIP** can be programed from a machine that is already set up and then used to set up other machines that are to be programed identically.

CHIP can also be programed from MasterMenu Online, MasterMenu Online is a software program that allows you to set up any 310 Control Module or 20 Series machine on your personal computer (PC). This information can then be stored by filename in you PC and is always accessible for any changes you may want to make the machine in the future, including pricing. To load **CHIP** from your PC requires harness (Pn 17500004), included in this package.

Touch Memory Button (**CHIP**) and Upload/download Harness (Pn 16800013)

The **CHIP** upload/download harness is attached to the Logic Board (LCB) on J1 (upper right hand corner) and the other end is mounted on the swing panel in a depression just above the display, six of these harnesses included in this package.

Chip Upload and Download Instructions.

1. Open Machine/Tower door, the display should indicate "Enter for MasterMenu".
2. Press Enter
3. Press the > until the display indicates "Configuration".
4. Press Enter
5. Press the > until the display indicates "Configuration Load".
6. Press Enter, the display should read "MasterMenu Online".
7. Press the + until the display indicates "Tmu Upload" (from Tmu to Lcb) or "Tmu Download" (From board to Tmu).
8. Press Enter
9. The display will indicate "Awaiting Download" or "Awaiting Upload".
10. Press the memory button **CHIP** against the socket and the display will indicate "Transfer in Progress". When the transfer is complete the display will prompt "Transfer Complete". If for any reason the transfer was unsuccessful the display will prompt "Transfer Error".

Note: To Use MasterMenu Online or Chip the Software on the Logic Board must Be at the Following Revision or Higher:
3.5 Flash Memory and 3.0 Microprocessor

Ventilating Fan:(Part #660441 - 120 Volts) (Part #660441-1 - 240 Volts) Export

The ventilating fan keeps a steady flow of air moving through the vendor cabinet. Installation of the fan takes only a few minutes. All vendors are wired with a fan plug on the junction box for easy installation.

Base Kits:

Base kits are available to make the vendor compatible with other manufacturers.

Gum and Mint:

Gum and Mint units are available as an option with API 120 series vendors. For information pertaining to loading or servicing gum and mint unit, refer to this service manual for loading instructions and service instructions.

optional equipment

Dual Spiral Shelf:

Snack shelves can be set up to have dual spirals per selection on the shelf. The dual spirals will help vend specialty items better.

Half Cycle Motors

The half cycle motors are used to vend thin items. This motor is used with a product divider that is positioned down the center of the coil. The product is placed on both the left and right hand side of the coil. When the motor turns, it turns only 180 degrees (½ revolution) rather than 360 degrees (full revolution).

Special Spirals (122/123 ONLY):

Special candy spirals are available for use in the four (4) and five (5) selection snack shelves on 122/123 machines only. For the sake of identification, the back end of these spirals are colored RED and should never be used in the eight (10) selection candy shelves.

These spirals allow vending products that are too wide for the standard candy columns but may be too thin for the regular snack spirals. A product pusher and spacer should be used where required. Part numbers for these special spirals are as follows:

400139-1	12 count special spiral
400140-1	15 count special spiral
400141-1	18 count special spiral
400142-1	24 count special spiral
400143-1	30 count special spiral
400151-1	20 count special spiral

NOTE: The difference between the standard candy spiral and the special candy spiral used in the wide snack columns is in the overall length of the spiral. The special spiral is shorter than the standard candy spirals.

CAUTION: Do not attempt to use the special candy spirals in an ten selection shelf.

Soup Dispenser 122/123: (Kit 750083)

A canned soup dispenser is available as an option for use in the four/five selection snack shelves. The dispenser is easy to install and holds up to nine cans in the unit.

Delivery Bin Cushion

A delivery bin cushion is available for use when vending heavy items.

Lexan Window

A Lexan window is available as a direct replacement for tempered glass.

The APi 125 Add On:

This unit is used in conjunction with a 121, 122, 123, 128 or 129 machine. The 125 operates from the selector panel of the host machine. Since the 125 machine has no control panel, the shelves are identical to the 123 models

(interchangeable). The 125 machine can only be purchased with six shelves as a 30 selection machine (all snack shelves) or a 35 selection machine (five snack shelves and one candy shelf). The 125 machine cannot have the following options: Gum & mint tray; chilled machine.

The APi 127 Add On:

This machine is used in conjunction with a 121, 122, 123, 128 Or 129 host machine. The 127 operates from the selector panel of the host machine. The 127 machine is available in a number of configurations with a maximum of 25 selections. The 127 is not available with gum & mint or the chiller option.

Point of Sale Window

The optional point of sale window is used for displaying POS material to your customer.

Golden Eye®

This optional Golden Eye® Bin Sensor ensures a positive vend every time. The sensor is installed in the delivery bin and senses that a product has been delivered. If no product was delivered, the spiral will turn make up to, two more attempts. If the product is not delivered after three attempts, the make another selection led will flash and the machine will allow the customer to make another selection or press the coin return and receive their change back.

The Refrigeration Unit

The Chiller unit is comprised of a 1/3 horsepower compressor and is a hermetically sealed system (no service ports). The compressor assembly is easily removed by taking out two screws and pulling the unit forward out the front of the cabinet. There is a wedge shaped insulator above the evaporator that mates with a matching wedge in the cabinet to ensure a tight seal. The refrigerant used in the refrigeration system is 134a and the charge is 11 ounces. The refrigeration system is controlled by the Digital Temperature Control. **Note: The Chiller can NOT be added at a later date.** The 120 series glass front merchandisers are designed to operate at ambient temperature of 55°F to 100°F (13°C to 38°C).

Digital Temperature Control

The Digital Temperature Control is located in the power supply box that is located behind the swing panel. The Digital Temperature Control Board contains a digital display and two programming buttons. There is a window toward the bottom of the power supply box that allows you to view the current temperature in the can compartment in Celcius only. To view the temperature in Fahrenheit, press and hold the 0 button for 3 seconds, and the current temperature will be shown on the main digital display. Located below the display window are the two programming buttons. Power to operate the Digital Temperature Control is supplied via the MDB connector on the logic board using communications cable P/N 660659. Power to operate refrigeration unit is supplied to the Digital Temperature Control Board immediately after the EMI filter and is switched on and off by a relay on the Digital Temperature Control Board. **Note: The only setting that is programmed on the digital temperature control is the Fan Speed when you have a chilled Snack area..**

Settable Temperature Range:

The settable temperature range is from 32°F to 70°F (0°C to 20°C). The recommended temperature for this machine is 42°F (6°C). The Digital Temperature Control will maintain the temperature as measured by the temperature probe (P/N 13600001-01). The harness for the probe is plugged onto the Digital Temperature Control Board at the connector marked JP3. The probe is mounted in cabinet below the bottom shelf on the right hand side, just above the intake air of the evaporator. An unplugged or open temperature sensor probe will display as -9°F (-9°C). A shorted or closed probe will display as 99°F (37°C).

Setting the Target Temperature:

The temperature setting is programmed in the logic Board. The Digital Temperature Control will allow you to set the temperature but it will change back to what is programmed in the logic board. To set the temperature:

1. Press and hold the * key while pressing the F1 button, the display will prompt "Set temperatures".
2. Press Enter, the display will prompt "CAB IN AMBIENT --- F".
3. Press the > and the t in ambient will start flashing.
4. Press the + key until the display says "CAB IN CHILLED +10 F".
5. Press the > and the "+10" will start flashing.
6. Press the + or - key to change the display to the desired temperature and press enter to set the temperature shown.

NOTE: To set temperatures in Celcius, Press the > to "F" and use the + key to change it to "C".

Refrigeration Processing:

The Digital Temperature Control maintains the temperature as measured by the temperature sensor. The chiller unit will be turned on at the set temperature plus 2°F and will be turned off at the target temperature minus 2°F. A minimum of 1 minute is required for both the cycle on and cycle off time of the relay. This insures the compressor is not cycled on and/or off to rapidly. Independent of the temperature, the relay, therefore the compressor, will be off 7 minutes every hour for a defrost cycle. The power for the Evaporator fan motor is constant and is not switched by the relay.

components

Power Supply

The 115 VAC power cord from the wall outlet comes into the machine and plugs into the back of the main junction box located on the bottom right side of the cabinet. The voltage output to the board is 24 volts and 8 volts and is plugged into the (L5 position) of the Logic Center Board.

Lighting System

There is only one fluorescent lamp in the Snackshop 120 series. The lamp is located on the top of the door and lights up the main product area. The starter is located on the hinge side of the lamp. The ballast and line filter is located on the top front left shelf support. Bulb part# 380022-5 (F18T8/CW-24).

Main Product Shelves:

There are five or six main product shelves per machine. Each selection has its own motor mounted to the back of the shelf. Every shelf has its own harness and plug for connecting to the remainder of the circuit through the cabinet receptacle, located in the rear right of the cabinet. The motors are the same on either shelf. It is possible in the Snackshop 120 series to exchange a five selection shelf with a ten selection shelf or visa versa. You also have the capability to gain ½ inch either up or down on any shelf. To do this the shelf should be removed and the cabinet back harness receptacle lowered or raised with the right & left shelf tracks.

Note: When exchanging the shelves, you will not need any parts but you will have to reprogram the machines for prices and selections.

Removal of Product Shelf:

- A. Lift up and push the lock levers toward the back of cabinet.
- B. Pull the shelf to its loading position.
- C. Grasp shelf in front and rear center. Lift front of shelf up above horizontal and pull shelf forward while lifting.
- D. To install shelf, reverse above procedure.

Delivery Bin:

This is located below the display window on the door and is mechanically operated. The linkage on the hinge side of the delivery bin may require occasional lubrication. Should the door become difficult to operate, place a small amount of grease on the arm tracks.

Removal of Delivery Bin:

- A. Remove the screws from the left and right side of the delivery bin. These screws fasten into the lower door brace. Remove the two screws and brackets at the top of the delivery bin.
- B. Grasp delivery bin on both sides and lift up and pull back. Should the bin be tight, rock it by lifting on one end, then the other.



Replacement of Delivery Bin:

- A. Locate lip on front edge of delivery bin over lower edge of opening in door and behind trim. Press down along lip to make sure it is fully engaged between door and trim.
- B. Install the four screws and two brackets, to secure bin to door.



Removal of Gum And Mint Motor:

Disconnect the two wires going to the motor and remove the four screws holding it to the shelf. The components attached to the front base can also be replaced. These consist of the gum and mint shelf front (Price tabs and selection), gum and mint shelf front base, gum and mint display front stop (plastic) and the gum and mint ejector.

Note: Before replacing the gum and mint motor it is helpful to tap the motor first with the screws. Assemble the four components together and mount them to the motor making sure that the head crank of the motor is inserted into the ejector. Replace the four screws and test vend that selection for proper operation.



Removal of Gum and Mint Shelf:

Under the gum and mint shelf remove the two screws holding the gum and mint receptacle harness bracket. Loosen the other two screws on each end of the gum and mint pusher stop strap and disengage it from the cabinet. Grasp the shelf and pull the shelf straight out. With the shelf out you can replace the gum and mint pusher by removing the screw.

Reverse the procedure to replace the shelf. Pay special attention when you put the gum and mint pusher stop strap back on that all the gum and mint pushers have spring tension and are behind the strap.

DEX/UCS

The APi 120 supports DEX/UCS Communications Protocol - NAMA Vending Industry Data Retrieval Standard. The machine will automatically recognize the DEX/UCS device when it is plugged into the control board and will recognize when the device initiates the communication protocol. The transmission/reception of data to the device will then take place automatically.

Printer Support

The machine is able to print to a 40 character wide printer connected to the serial port. The communication is as specified by the user in the Printer Setup Menu . The machine uses only standard printer control codes to maximize the number of possible supported printers. The machine is able to print any of the following types of information set by a menu item in the MIS Menu heading:

- MIS Data
- Machine Setup/Configuration Parameters
- Diagnostic Information

When an attempt is made to output data to the printer without a printer connected, an error message will be displayed indicating that the printer is not connected.

The 20 Series Machines Support the 24V Micromech, executive, and MDB protocols for Coin Mechs, Validators and Card Readers.

NOTE: DO NOT ATTEMPT TO OPERATE TWO DIFFERENT PERIPHERALS SIMULTANEOUSLY. FOR EXAPMLE: MDB WITH PULSE OR MICROMECH. Peripherals in Column 1 and 2 can work together and columns 4 and 5 can work together.

	Micro Mech 24V 15 pin	Pulse Validator 24V	Executive	MDB Coin Mechanism	MDB Bill Validator
Mars	TRC-6010XV VN4010XV	VN2502-U5E VN2512-U5E VFM1-L2-U4C VFM3-L2-U4C	540 560	TRC-6510 TRC-6512 VN-4510	VN2502-U5M VN2512-U5M
CoinCo	9302 LF USD-L701 USQ-L701	BA32SA BA32R		9302-GX USQ-G701 USO-G703 USQ-L701	BA32SA** BA32R

The APi 20 Series will automatically determine at power up which peripherals are connected and configure itself accordingly.

components

Vend Motors

The vend motors used in the APi 120 machines have been specifically developed to operate with the APi MasterVend™ Control System. One primary difference that distinguishes the new motors from previous motors is the presence of an eight sided star at the drive hub of the motor. This permits the stopping position of the spiral to be customized by the operator to ensure the best possible delivery of product. Motors used in the 120 & 320 are of the fast trac style, with all electronics required to correctly operate the motor contained inside the gear case or the motor housing and no external control board. Each of the motors used with the MasterVend™ Control System will have two terminals. The two terminals continue to be used to identify the shelf and column (selection) to be vended.

SHELF WIRING DIAGRAM



Each motor requires two wires to operate correctly. These wires are: shelf common, and selection.

Each selection on a shelf has the same common shelf wire - all shelf harness use the wire #12 as a shelf common. This corresponds to the selected shelf wire in the cabinet harness. The terminal for the shelf common in the harness is the smallest of the two.

Selection numbers are assigned from left to right, starting with selection 0. Each selections number corresponds to the number of the wire for that selection.

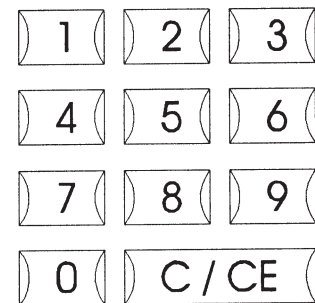
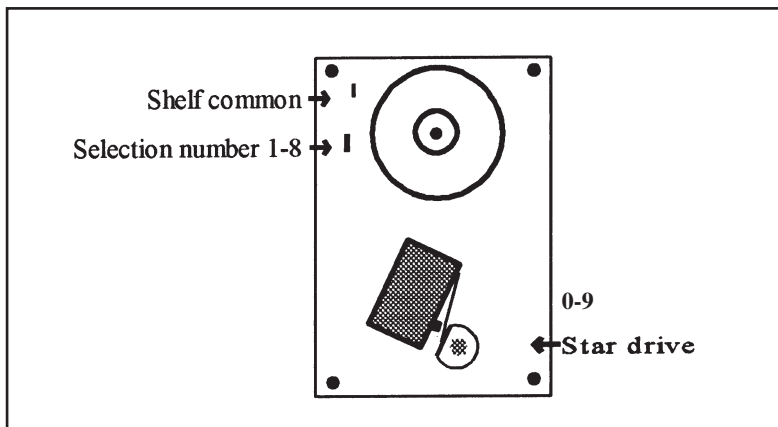

Figure 2.4

Selection System

The selection system used with the MasterVend™ Control System is different from all previous alpha-numeric systems we have manufactured. The eleven digit selection panel (see figure 2.4) is located on the front control bezel and consists on the numbers 0 through 9 and the letter C, which is defined as a clear button. The selection system used with the MasterVend™ Control System is all numeric and uses three digits to identify all the selections. The first digit is used to determine which cabinet is selected, the second digit determines the shelf selected, and the third digit, the selection on that shelf. The left or first selection on each shelf is designated as selection 0, and on a ten select shelf the selection numbers would be increase by one, so that the right hand selection will be selection 9. The numeric keys on the selector panel can be used to enter numeric data any time it is required during setup or maintenance of the equipment.

Wildcarding

Anywhere in the programming where you are allowed to enter selection numbers you can use wildcarding. Wildcarding makes use of the * key on the MasterMenu keypad. The * key in any position means all. The following examples are using wildcarding for pricing the machine:

Entering *** will price all cabinets, all shelves & all selections to the price shown.

Entering 1** will price cabinet 1, all shelves & selections to the price shown.





Entering 11* will price cabinet 1, shelf 1, all selections to the same price.

MasterMenu™ Keypad







The MasterMenu™ keypad (see figure 2.3) is located on the front of swing out panel directly below the selection keypad. The MasterMenu™ keypad is only active when the Control module door is open, so even in the event of vandalism to the control bezel, no access to the control functions is permitted. The MasterMenu™ keypad consists of seven function buttons, a  key, four coin payout buttons and the eight keys used to operate the MasterMenu™ functions. The entire keypad becomes active once the machine door is opened.



Function Buttons

The seven function keys (F1-F7) are assigned to specific pre-determined functions, primarily for route service personnel.

The  key shall be used to enter the character “*”. Pressing the  key before one of the function keys  through  are specific to the second level of menu heading/items currently active. The  key can also be used for wildcarding in the pricing and motor configuration menus. For more information on wildcarding see the configure motors menu in section 4 of this manual.

Coin Payout Buttons



The four coin payout buttons are used to pay coins out of an L+ or a standard US (dummy mech). The four coin payout buttons are , ,  and . The four coin payout buttons may also be used to enter pricing information while assigning prices. For example, to enter a price of \$.65, pressing the  key twice, the  key once and the  key once, would result in .65 appearing on the display. See the price setting section for additional information.

The  key is used for exiting the current menu without making any changes prior to commitment. Note: Closing the main cabinet door will have the same effect as if the user depressed the  key and causes the machine to exit the MasterMenu™ System and return to Operational Mode.

The  key provides a dual purpose operation. It provides the a mechanism for choosing a menu heading. It also provides a means to commit insertions/modifications/deletions made in a menu item.

The  and  keys provides are used for incrementing and decrementing the available choices in a menu.

Note: Anywhere in this manual that the  or  keys are defined to sequence through numeric data, the front panel may be used as an alternate input source.

The  and  keys have a dual purpose operation. They provide a means to select the menu heading immediately to the left or right of the current menu heading. When inserting data within a menu, these keys also provide a means to move the cursor from its current position to the position directly to its left or right.

The  key is used to delete the character on the current cursor position, shifting all subsequent characters to the right of that position left by one.

The  key provides a mechanism to insert a character to the left of the current cursor position, shifting all characters to the right of that position (including the current character) right by one.

Note: Depressing a function key will not cause you to enter the MasterMenu™ System.

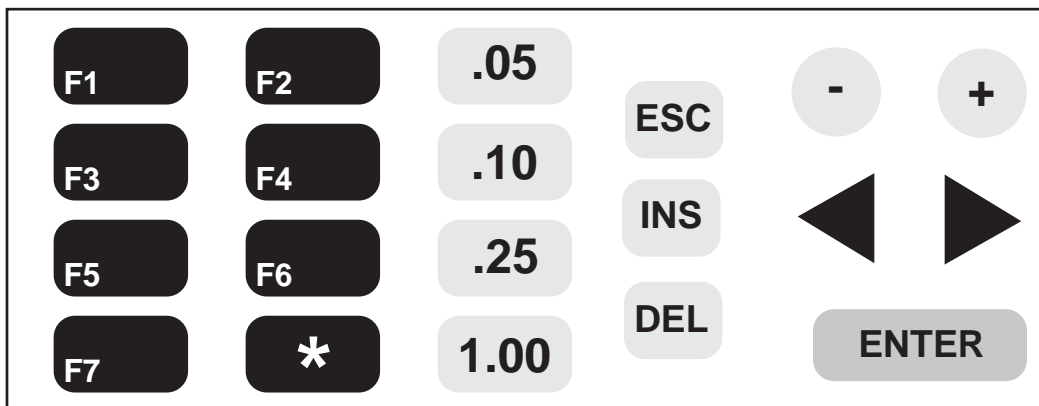

Control System and Boards

The MasterVend™ Control System consists of up to three different boards, depending on the configuration. All Model 120 and all towers consist of the LogicCenter board (LCB) and the display board. When a machine is slaved off of the APi 120 (320 series 127) this cabinet will have a Food Driver Board (FDB) contained in it.

LogiCenter Board (LCB)

The LCB interfaces with the FDB (when used), display board, selector panel, MasterMenu keypad, coin mechs, bill validators and all other peripherals. The LCB also stores all the programming and mis information.

Food Driver Board (FDB)

This board is only used in a food/frozen machine or a slave snack. This board contains all the temperature monitoring functions for cabinet that it is contained in, and communicates with the LCB via a 6 wire computer level interconnect harness. The FDB has three LEDs on it and the status of the FDB can be determined by observing the LEDs.

The Front Panel Display

The display is capable of displaying 20 alpha-numeric characters. The supported character set includes:

- Upper and lower case alphabetic characters "A" through "Z"
- Numeric characters "0" through "9"
- Special characters: (,), [,], ., ', -, =, \$, /, \, *, ^, +, , , ", ?, _.

The Chime

The chime will sounded when the following events occur:

- Three times when an invalid key sequence is entered from either the front panel or the MasterMenu™ Keypad.
- Three times when the customer enters an invalid key sequence from the front panel.
- Five times when the customer has won a free vend due to WINNER MODE.
- For fifteen seconds if a motor configuration mismatch is detected when the main cabinet door is closed.
- Five times when the customer attempts to purchase a sold-out item as determined by spiral selection.
- A single time to indicate the acceptance of an action by the control system.

Introduction

The Dual Zone Snack merchandiser is designed to allow two separate temperature settings in one machine. The cabinet is divided into two sections determined by the placement of the barrier shelf with the insulated bottom and an air duct Barrier. A 24vdc circular fan (P/N 16700018) is mounted just above the barrier and circulates chilled air in the upper section of the cabinet. Pressing and holding the 0 button on the selection keypad for three seconds will show the current temperature in the machine for both the upper and lower section of the cabinet in Fahrenheit, Pressing and holding the C/CE button will show the temperatures in Celsius. It is not recommended that the shelf configurations be modified in the field.

Lower (Primary) area

The primary area is below the barrier shelf and consists of the bottom three shelves. The barrier shelf has an insulating panel attached to the underside of the shelf and insulating blocks along each shelf rail.

Each of the shelves in the primary area has a clear plastic deflector curtain covering the front of the shelf. The curtain is attached to the underside of the shelf above. This curtain prevents the colder air in the lower section from circulating throughout the machine, and prevents condensation from developing on the exterior glass of the machine. As an item is vended from a shelf in the primary area, the curtain pivots forward to allow the product to drop into the delivery bin, and then return to its normal vertical position.

The temperature in the primary area is settable from 32° F to 70° F (0° C to 21° C) or ambient. The primary area is normally used for can drinks or juices. The recommended temperature setting for can drinks is 38° F (3° C).

Note: NAMA requirements state that if cold perishable food is sold, there must be a Health Control cutoff device. This machine does not have a Health Control.

Upper (Secondary) area

The secondary area is above the barrier shelf. Although the temperature in the secondary area is settable from 32° F to 70° F (0° C to 21° C), the upper section of the cabinet will only be able to achieve approximately 15° F below the external ambient temperature. The cool air in the upper section of the cabinet is circulated by a 24Vdc fan mounted in the air duct to the right of the lowest shelf in the upper area. If the secondary area is 2° F (1° C) or warmer than the set temperature, the fan speed runs at 50% of maximum, circulating the air through the upper section of the cabinet. If the secondary area is at or below the set temperature, the fan runs at 20% of maximum.

The Refrigeration Unit

The refrigeration unit is comprised of a 1/3 horsepower compressor and is a hermetically sealed system (no service ports). The Dual Zone uses the same

Refrigeration unit as the Model 121,122 or 123 chilled machines. The compressor assembly is easily removed by taking out two screws and pulling the unit forward out the front of the cabinet. There is a wedge shaped insulator above the evaporator that mates with a matching wedge in the cabinet to ensure a tight seal. The refrigerant used in the refrigeration system is R134a and the charge is 11 ounces. The refrigeration system is controlled by the Temperature Control Board. The 123 Dual Zone merchandisers are designed to operate at ambient temperature of 55°F to 90°F (13° C to 32° C).

Note: The chiller can NOT be added at a later date.

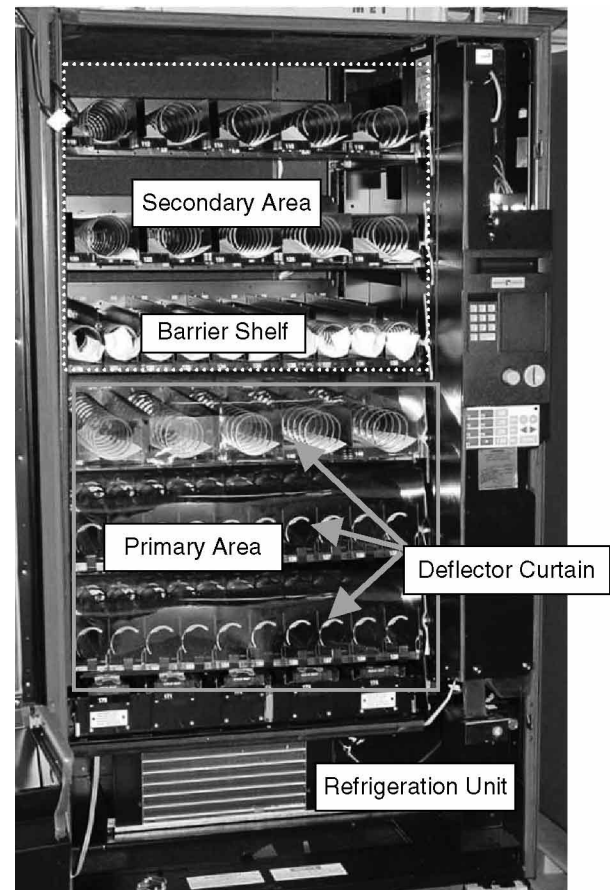

Primary Dual Zone Components

APi 123 Dual Zone Manual Supplement

Temperature Control Board

The Dual Zone Temperature Control board (P/N 13600005-01) is located in the power supply box that is located behind the swing panel. Power to operate the Dual Zone Temperature Control Board (DZCB) is supplied via the MDB connector on the logic board using a short communications cable (P/N 660649-1). Mains voltage to operate the refrigeration unit is supplied to the DZCB immediately after the EMI filter and is switched on and off by a relay located on the DZCB. The Dual Zone Temperature Control Board will maintain the temperature as measured by the two temperature probes (P/N 13600001-01). The lower section of the cabinet is controlled by the probe connected to the pins marked JP3, the upper section of the cabinet is controlled by the probe connected to the pins marked JP5. The fan for the secondary area is connected on the pins marked JP1 and the fan speed is controlled by the temperature probe in the upper section of the cabinet.

Setting the target temperature:

The temperature setting is programmed in the Logic Control Board (LCB). To set the temperature:

1. Press and hold the * key while pressing the F2 button, the display will prompt "Set Temperatures".
2. Press Enter, the display will prompt "TC_L Ambient --- F". TC_L is the lower section of the cabinet.
3. Press the > and the t in ambient will start flashing.
4. Press the + key until the display says "TC_L Chilled +32 F".
5. Press the > and the "+32" will start flashing.
6. Press the + or - key to change the display to the desired temperature and press enter to set the temperature shown (recommended 38°F or 3°C for cans).
7. Press Enter to lock in the set temperature.
8. Press the > two times and the L in "TC_L" will be flashing.
9. Press the + key and the display will say "TC_H Ambient --- F". TC_H is the upper section of the cabinet.
10. Repeat steps 3-7 above to set the temperature for the upper section of the cabinet. Recommended temperature for the upper section of the cabinet is not less than 70°F (21°C)

Note: to set temperatures in Celsius, Press the > to "F" and use the + key to change it to "C".

Refrigeration Processing:

The Digital Temperature Control maintains the temperature as measured by the temperature sensor. The chiller unit will be turned on at the set temperature plus 2°F and will be turned off at the target temperature minus 2°F. A minimum of 1 minute is required for both the cycle on and cycle off time of the relay. This insures the compressor is not cycled on and/or off too rapidly. Independent of the temperature, the relay, and therefore the compressor, will be off 7 minutes every hour for a defrost cycle. The power for the Evaporator fan motor is constant and is not switched by the relay.

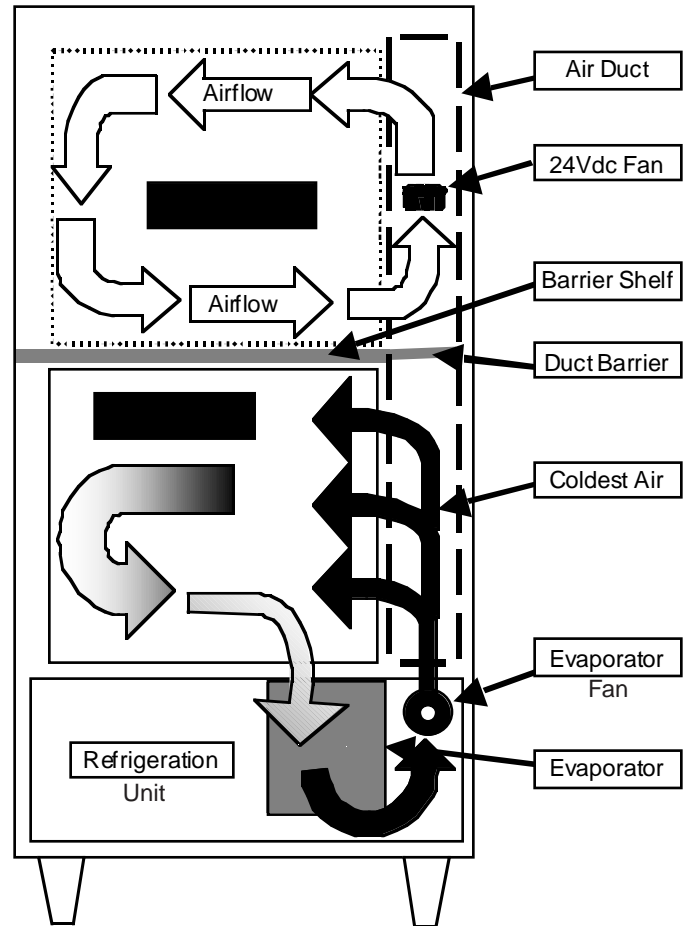

DUAL ZONE AIRFLOW DIAGRAM

The APi 120 machine is shipped with the software already set up, the only setup that is necessary before putting the machine on location is to set the prices.

SET PRICES

Press the F4 on the MasterMenu keypad

Press **ENTER** to access **SET PRICE menu**. **<**

Press **>** 1 time to price.

Using the selection buttons, enter desired price, Calculator style.

Press **<** 1 time to selection.

Using the selection buttons, enter desired selections at the price shown

Repeat the above process for all additional prices to be set.

ESC to exit.

The F 1 - F7 keys on the MasterMenu keypad are preprogrammed to perform a specific function. On the next page you will find a Copy of the decal on the door of the machine. This decal explains what the function keys are used for as well as how to use them. For most applications the function keys give you all the options and functionality necessary. For advanced set up options see the operating system section of the manual.

function keys

Press F1 - View Historical MIS Menu

Press **ENTER** to View Historical MIS
Use **>** to scroll through MIS data. Press **ESC** to exit.

Press F2 - View Errors Menu

Press **ENTER** to View Errors, the first error will appear.
Use **>** to Scroll through the error list.
Pressing F2 when viewing an Error will cause extended diagnostics to be displayed.
Press **ESC** to exit or **>** to go to next error.

Press F3 - Clear Errors Menu

Press **+** or **-** to toggle between "N" and "Y".
Press **ENTER** clear Errors. Press **ESC** to exit.

Press F4 - Set Price Menu

Press **ENTER** to access Set Price menu.
Press **>** 1 time to price.
Using the selection buttons, enter desired price, calculator style.
Press **<** 1 time to selection.
Using the selection buttons, enter desired selections at the price shown. Repeat the above process for all additional prices to be set.
Press **ESC** to exit.

Press F5 - Check Price Menu

Press **ENTER** to View Price and Product Code information. Using the selection buttons, enter selection number of price to be checked. Press **ESC** to exit.

Press F6 - Test Vend Menu

Use **+** or **-** to toggle between "N" and "Y".
Press **ENTER** and the front panel keypad becomes active. Press **ESC** to exit.

Press F7 - Tube Fill

Press **ENTER** the display will prompt TO 0.00 0.00
Drop coin through the top of the coin mech and the TO (TO-T3) will change to indicate which tube the coin went into, the first set of numbers indicate the value of coins in that tube and the second set of numbers indicate the value of coin in all tubes.
Press **ESC** to exit. **NOTE: It is only necessary to teach the coin mech how much money it has if you have changed the payback option or if you track coin tube accountability.**

The second level of Menu items can be accessed by pressing and holding in the * key while pressing one of the function buttons F1 - F7.

Press * F1 - Set Motor Pairs

Press **ENTER** to access Set Motor Pairs.
Press **>** 1 time to change the paired state of the motor. Use the **+** and **-** key to toggle the paired state of the motor between Y (yes) and (no). Press **<** 1 time to selection. Using the selection buttons, enter desired selections for paired state shown.
Press **ESC** to exit.

F1 MIS Motor Pairs	F2 View Errors Set Temps
F3 Clear Errors Set Time	F4 Set Price Bill Escrow
F5 Check Price Door Test	F6 Test Vend Transmit MIS
F7 Tube Fill Set Defrost	*

Press * F2 - Set Temps

Press **ENTER** to access Set Temperatures menu.
Use the **<** and **>** keys to move through cabinet, temperature range, target temperature and temperature scale fields.
Use the **+** and **-** keys to increase or decrease the currently selected field.
Press the **ENTER** key when the desired temperature settings are displayed
Press **ESC** to exit.

Note: If you are NOT using a second cabinet, you do not need to set Cabinet 2.

Press * F3 - Set Time and Date

Press **ENTER** to access Set Time and Date Menu.
Use the **<** and **>** to move left or right through the time/date fields.
Use the **+** or **-** Keys to change the currently selected field.
Press **ENTER** to update the machine with the current date and time shown on the display.

Press * F4 - Bill Escrow

Press **ENTER** to access Bill Escrow.
Use the **+** and **-** to toggle between Y/N.
Press **ENTER** to commit to changes.

Press * F5 - Trap Door Test

Press **ENTER** to access Trap Door Test Menu.
Use the **<** and **>** to move through the door operation and cabinet fields.
Use the **+** or **-** to toggle the above fields
Press **ENTER** to start test.

Press * F6 - Transmit MIS Data

Press **ENTER** to access Transmit MIS Data.
Use the **<** and **>** to move through the available Peripherals.
Press **ENTER** to transmit MIS Data. Note: When using Dex the MIS information will automatically transmit upon connection.

Press * F7 - Set Defrost

Allows you to customize target defrost time for cabinets 1 and 2. It is not necessary to set this menu the default defrost time is set to a default at midnight.

TABLE OF CONTENTS

Operating System	4.01
Operational Mode	4.01
Service Mode	4.01
MasterMenu™ System	4.02
Quick Reference Directory for MasterMenu™	4.03
Mis Menu	4.04
View MIS Data Menu	4.04
Transmit MIS Data Menu	4.05
Clear MIS Data Menu	4.07
Tube Fill Menu	4.07
Software Revision	4.07
Setup Menu	4.08
Bill Escrow Menu	4.08
Free Vend Menu	4.08
Winner Vend Menu	4.08
Multiple Vends Menu	4.08
Force Vend Menu	4.08
Combo Vend Menu	4.08
Set Max Payout Menu	4.09
Set Payout type	4.09
Configuration Menu Items	4.10
Motor Pairs	4.10
Configuration Upload/Download Menu	4.10
Set Temperatures Menu	4.10
Set Function Keys Menu	4.11
Set Spiral Count Menu	4.12
Printer Setup Menu	4.12
Set Lockout Menu	4.12
Free Token/Coupon Menu	4.12
Speech Synthesis Menu	4.12
Setup Defrost Menu	4.12
Diagnostic Menu Items	4.14
View Errors Menu	4.14
Clear Errors Menu	4.14
Test Vend Menu	4.14
Motor Test Menu	4.14
Baffle Door Test Menu	4.14
Security Menu Items	4.15
Machine Identification Menu	4.15
Serial Number Menu	4.15
Password Definition Menu	4.15
Password Prompt Menu	4.15
Set Security Level Menu	4.15
Machine Reset Menu	4.15
Factory Test Menu Item	4.15

table of contents continued

- Time Functions Menu Items4.16
 - Setting Discount Time of Day and Day of Week Menu4.16
 - Discount Options Menu4.16
 - Set Time and Date Menu4.17
 - Setting Shutdown Time of Day and Day of Week Menu4.17
 - Shutdown Options Menu4.17

- Price Menu Items4.18
 - Price Assignment Menu4.18
 - View Pricing Menu4.18

- Display Menu Items4.19
 - Set Menu Order Menu4.19
 - Set Language Menu4.19
 - Set User Messages Menu4.19
 - Set Out of Service Menu4.20
 - Set After Sale Message Menu4.20

Introduction

The APi MasterMenu™ system is user friendly and provides a common look and feel across all menu items. The system allows the user to move freely through the menus and provides ease of insertion, modification, and deletion of operational parameters and data. In addition, the system provides the user with status and diagnostic messages to aid in the use and service of the machine.

Operational Mode

The Operational mode provides the machine with the ability to vend products. The machine is in Operational Mode whenever the main cabinet door of the machine is closed. Upon opening of the main cabinet door, the machine will remain in Operational Mode until the **ENTER** key is depressed at which time it will enter the Service Mode. This allows for vends to occur while the main cabinet door of the machine is open and the user has not yet entered Service Mode by depressing the **ENTER** key. This is referred to as Enhanced Operational Mode. Enhanced Operational Mode differs from Operational Mode in that the Function keys and Payout keys are active. If any key in either of these sets of keys is depressed, it will perform its function and return the machine to Enhanced Operational Mode when complete.

The Service Menu provides access to all configurable items in the machine as well as retrieval of MIS information. The Service Menus shall only be available when the machine is in Service mode.

Service Mode

Service Mode provides the ability to configure the machine. When the Control Module door is opened, the display indicates "ENTER FOR MASTERMENU" if no errors have been logged, or "ERRORS-NN" in the case where errors exist (where "NN" is the number of errors). The machine returns to Operational Mode whenever the main cabinet door is closed.

mastermenu™ system





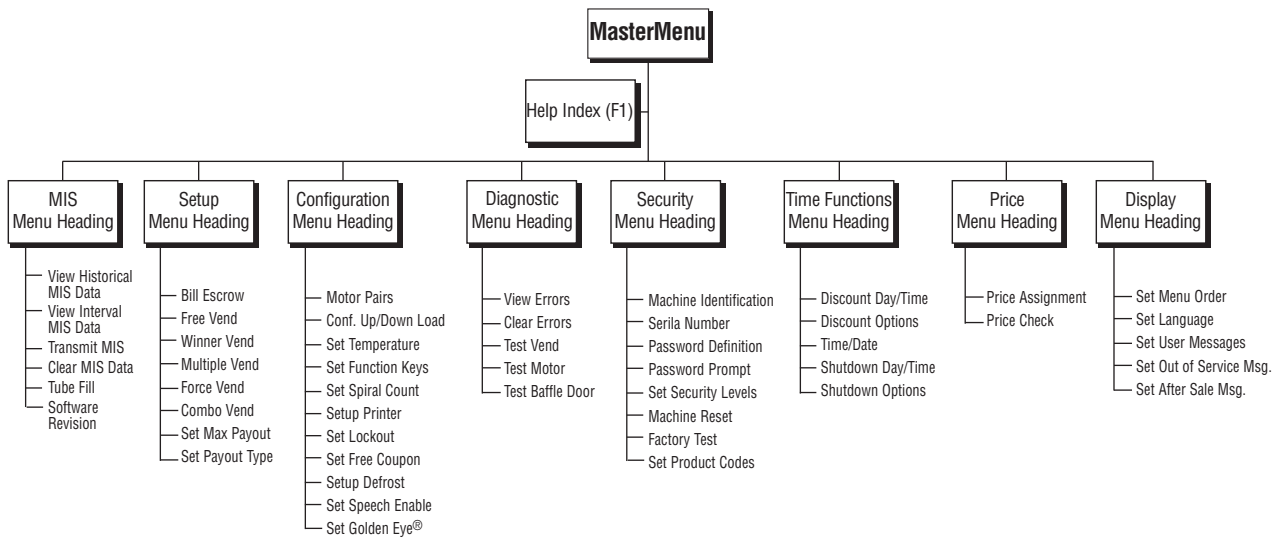







The MasterMenu™ System provides a set of text based Service Menus which allows interface to all functions of the machine. Menus appearing at the upper most level of the menu system are referred to as Menu Headings. Menus appearing under the Menu Headings are referred to as Menu Items.

Figure 1.1: illustrates a diagram of the MasterMenu™ System.



quick reference directory for mastermenu™

The following is a quick reference for the keys on the MasterMenu™ keypad, for a detailed list see page 2.05 of the components section.

-  Used to enter the character “*”.
-  The four coin payout buttons may also be used to enter pricing information while assigning prices.
-  Used for exiting the current menu without making any changes.
-  Used to choose a menu heading and to commit to insertions/modifications/deletions made in a menu item.
-  and  Used to move the cursor from its current position to the position directly to its left or right also to select the menu heading immediately to the left of the current menu heading.
-  and  Used for incrementing and decrementing the available choices in a menu .
Note: Anywhere in this manual that the  or  keys are defined to sequence through numeric data, the front panel may be used as an alternate input source.
-  Used to delete the character on the current cursor position.
-  Used to insert a character to the left of the current cursor position.

Note: Depressing a function key will not cause you to enter the MasterMenu™ System.

Operating System Quick Reference Index

On the bottom of each page is a quick reference index (figure 1.2). The white box indicates where you are in the MasterMenu™ System, the shaded areas can be used as a reference to move through the sections of the manual. Figure 1.2 below indicates that you would be in the diagnostics menu.

Figure 1.2

M I S MENU	SETUP MENU	CONFIGURATION MENU	DIAGNOSTIC MENU	SECURITY MENU	TIME FUNCTIONS	PRICE MENU	DISPLAY MENU
------------	------------	--------------------	-----------------	---------------	----------------	------------	--------------

mis menu heading

The MIS Menu heading contains all the MIS (accounting) information collected by the machine.

Pressing ENTER when the display indicates MIS will cause the display to be updated with View Historical MIS.

Use the < or > arrow keys to scroll through the following menu items:

View Historical MIS View Interval MIS Transmit MIS Data Clear MIS Data Tube Fill Software Revision

Pressing ENTER when any of the above items are on the display will give you access to that Menu Item.

Below is a detailed list of each of the above Menu Items:

Display

VIEW HISTORICAL MIS Press ENTER
 hTOT SALES 00.00 Use the < or > keys to scroll through the MIS Data.

VIEW INTERVAL MIS Press ENTER
 iTOT SALES 00.00 Use the < or > keys to scroll through the MIS Data.

Table 4.1 below is a list of all the viewable MIS Data

NAME	Display Format of Historical MIS	Display Format of Interval MIS
Total Value of Sales	hTOT SALES 000000.00	iTOT SALES 000000.00
Number of Vends	h# VENDS 0000000	i#VENDS 0000000
# of Test Vends	h# TEST VNDS 0000000	i# TEST VNDS 0000000
# of MIS Resets	h# MIS RESETS 0000000	i# MIS RESETS 0000000
# of Machine Resets	h# MACH RESET 0000000	i# MACH RESET 0000000
Number of Bills Stacked	h\$ BILLS 000000.00	i\$ BILLS 000000.00
Value of Coins To Tubes	h\$ to TUBE 000000.00	i\$ TUBES 000000.00
Value of Coins In Tubes	h\$ in TUBE 000000.00	i\$ TUBES 000000.00
Value of Cash Dispensed	h\$ DISPENSED 000000.00	i\$ DISPENSED 000000.00
Value of Cash Dispensed Manually	h\$ MAN DSP 000000.00	i\$ MAN DSP
Value of Cash In	h\$ CASH IN 000000.00	i\$ CASH IN 000000.00
# of Free Vends	h# FREE VENDS 0000000	i# FREE VENDS 0000000
Value of Free Vends	h\$ FREE VENDS 000000.00	i\$ FREE VENDS 000000.00
# of Token Vends	h# TOKEN VENDS 0000000	i# TOKEN VENDS 0000000
Value of Token Vends	h\$ TOKEN VENDS 000000.00	i\$ TOKEN VENDS 000000.00
Value of Coins To Cash Box	h\$ BOX 000000.00	i\$ BOX 000000.00
Value of Discount, Discounted Vends	h\$ OF DISC 000000.00	i\$ OF DISC 000000.00
# of Discounted Vends	h# DISC 0000000	i# DISC 0000000
Value Discount, for Combo Vends	h\$ COMBOS 000000.00	i\$ COMBOS 000000.00
# of Combo Vends	h# COMBOS 0000000	i# COMBOS 0000000
# of Winner (Free) Vends	h# WINNERS 0000000	i# WINNERS 0000000
Value Winner (Free) Vends	h\$ WINNERS 000000.00	i\$ WINNERS 000000.00
# of Card Vends	h# CARD VENDS 0000000	i\$ CARD VENDS 0000000
Value of Card Vends	h\$ CARDS 000000.00	i\$ CARDS 000000.00
Value/Number of Vends by Cabinet	h\$/# BY CABINET C01- 00000.00 000000 C02- 00000.00 000000	i\$/# BY CABINET C01- 00000.00 000000 C02- 00000.00 000000
Value/Number of Vends By Sel #	h\$/# BY SELECTION NUMBER	i\$/# BY SELECTION NUMBER
Time of Last Vend By Selection #	TIME BY SELECTION 110- HH:MM DD/MM/YY DEF1- HH:MM DD/MM/YY DEF1- HH:MM DD/MM/YY	TIME BY SELECTION 110- HH:MM DD/MM/YY DEF1- HH:MM DD/MM/YY DEF1- HH:MM DD/MM/YY
Last Defrost Cab-1	DEF1- HH:MM DD/MM/YY	DEF1- HH:MM DD/MM/YY
Last Defrost Cab-2	DEF1- HH:MM DD/MM/YY	DEF1- HH:MM DD/MM/YY
Door History For Tower	DOOR OPEN TOWER	DOOR OPEN TOWER
(Repeated For Last 5 Openings)	1-MM HH:MM DD/MM/YY	1-MM HH:MM DD/MM/YY
Door History Cab-1	DOOR OPEN CAB-1	DOOR OPEN CAB-1
(Repeated For Last 5 Openings)	1-MM HH:MM DD/MM/YY	1-MM HH:MM DD/MM/YY
Door History Cab-2	DOOR OPEN CAB-2	DOOR OPEN CAB-2
	1-MM HH:MM DD/MM/YY	1-MM HH:MM DD/MM/YY
Mach Id #	MACH ID 1234567890	MACH ID 1234567890
Mach Asset #	API1234	API1234
Mach Serial #	SER NUM 123456789012	SER NUM 123456789012
Software Version #	PXX LXX.XX C1XXC2XX	PXX LXX.XX C1XXC2XX

M I S MENU	SETUP MENU	CONFIGURATION MENU	DIAGNOSTIC MENU	SECURITY MENU	TIME FUNCTIONS	PRICE MENU	DISPLAY MENU
------------	------------	--------------------	-----------------	---------------	----------------	------------	--------------

Display

TRANSMIT MIS DATA
TRANSMIT TO DEX

Press ENTER

Use the > to PRINTER or Press ENTER to TRANSMIT TO DEX (Dex transfer is automatic on connection of dex device on software version 3.50 or higher) See table 4.2 for a list of MIS Data transferred and Dex definitions.

TRANSMIT TO PRINTER

Press ENTER then use the + or – key to toggle between SHORT LIST and FULL LIST. Press ENTER to start the print. See table 4.3 for a list of MIS data transferred to the printer.

Table 4.2

DEX/UCS	Definition
ID1*0987654321*LCB120*3993* API**1234567890	* Serial # * Model # * Software Version * Machine Location** Machine ID #
VA1*300*9*300*9	*Total Cash (H) * Total Vends (H) * Total Cash (I) * Total Vends (I)
VA2**2**2	** # Test Vends (H) ** # Test Vends (I)
VA3*50*1*50*1	*Value of Winner (free) Vends (H) * Number of Winner (free) Vends (H) * Value of Winner (free) Vends (I) * Number of Winner (free) Vends (I)
TA2***0*0*0*0	*** Value of Token Vends (I) * Number of Token Vends (I) * Value of Token Vends (H) * Number of Token Vends (H)
PA1*CAB1	* Cabinet 1
PA2*7*250*7*250	* # of Vends for PA1 above (H) * Value of Vends (H) * # of Vends (I) * Value of Vends (I)
PA1*CAB2	* Cabinet 2
PA2*3*150*3*150	* # of Vends for PA1 above (H) * Value of Vends (H) * # of Vends (I) * Value of Vends (I)
CA3*600*0*300*300*600*0*300	*Value of Cash in (I) * Value of Cash to box (I) * Value of cash to tubes (I) * Value of bills to box (I) * Value of Cash in (H) * Value of cash to box (H) * Value of Cash to Tubes (H) * Value of Bills to box (H)
CA4*200*540*200*540	Value of Cash Dispensed (I) * Value of Cash Manually Dispensed (I) * Value of Cash Dispensed (H) * Value of Cash Manually Dispensed (H)
CA7*50*50	* Value of Discounts (I) * Value of Discounts (H)
CA15*0	Value of Coin Tubes
DA2*0**0*	* Value of Card Sales (H) * Number of Card Sales (H) * Value of Card Sales (I) * Number of Card Sales (I)
EA2*MIS RES**0	*MIS Resets ** # of MIS Resets Since Installation
EA2*MACH RES**0	* Machines Resets * # of Machine Resets Since Installation
MA5*DISC*1*1	* Discounts * # of Discounts (H) * # of Discounts (I)
MA5*COMBO*50*1*50*1	* Combo * Value of Combo Vends (H) * # of Discount Vends (H) * Value of Combo Vends (I) * # of Discount Vends (I)
MA5* Winner *50*1*50*1	* Winner * Value of Winner Vends (H) * # of Winner (H) * Value of Winner Vends (I) * # of Winner Vends (I)
LS*0001	* Loop Header (Start of information by selection or product code)
PA1*110*20*001*0 (duplicated for all selections in the machine)	* Selection # * Selection Price * Product code * Spiral Count
PA2*7*250*7*250 (duplicated for all selections in the machine)	* # of Vends for PA1 above (H) * Value of Vends (H) * # of Vends (I) * Value of Vends (I)
PA5*TIME*020421*1655 (duplicated for all selections in the machine)	* Time of last Vend for PA1 above * YYMMDD * HHMM Note: If date = 000000 Selection is not in use.
EA1*M DOOR 1*020421*1655*60 (repeated 5 times for last 5 door openings)	* Last Time of Door Opening for Tower or Snack * YYMMDD * HHMM * MM, # of Minutes Door was Open
EA1*C1 DOOR 1*000000*0000*00 (repeated 5 times for last 5 door openings)	* Last Time of Door Opening for Cabinet 1 * YYMMDD * HHMM * MM, # of Minutes Door was Open
EA1*C2 DOOR 1*000000*0000*00 (repeated 5 times for last 5 door openings)	* Last Time of Door Opening for Cabinet 2 * YYMMDD * HHMM * MM, # of Minutes Door was Open
EA1*DEF 1*000000*0000	* Last Time of Defrost for Cabinet 1 * YYMMDD * HHMM
EA1*DEF 2*000000*0000	* Last Time of Defrost for Cabinet 2 * YYMMDD * HHMM

I = Interval vends since last reset

H = Historical vends

M I S MENU	SETUP MENU	CONFIGURATION MENU	DIAGNOSTIC MENU	SECURITY MENU	TIME FUNCTIONS	PRICE MENU	DISPLAY MENU
------------	------------	--------------------	-----------------	---------------	----------------	------------	--------------

mis menu heading

Table 4.3

Below are the definitions for the MIS information downloaded to a printer.

S - indicates short list

F - indicates full list and includes everything in the shortlist

Field	Size	Definition	Field	Size	Definition
ID101	S	LCB Serial Number	EA101	S	Door Opening, Tower/Snack Header
ID102	S	LCB Model Number	EA102	S	YYMMDD Open for Tower/Snack
ID103	S	LCB Software Revision	EA103	S	HHMM of Open for Tower/Snack
ID106	S	LCB Machine (Asset) Number	EA104	S	Minutes of Opening Tower/Snack
VA101	S	Value of all Paid Sales (H)			
VA102	S	Number of all Paid Sales (h)	EA101	S	Door Opening for Cabinet 1 Header
VA103	S	Value of all Paid Sales (I)	EA102	S	YYMMDD of Opening for Cab 1
VA104	S	Number of all Paid Sales (I)	EA103	S	HHMM of Opening for Cab 1
VA202	S	Number of Test Vends (H)	EA104	S	Minutes of Opening Cabinet 1
VA204	S	Number of Test Vends (I)			
VA301	S	Value of Winner (Free) Vends (H)	EA101	S	Door Opening for Cabinet 2 Header
VA302	S	# of Winner (Free) Vends (H)	EA102	S	YYMMDD of Opening for Cab 2
VA303	S	Value of Winner (Free) Vends (I)	EA103	S	HHMM of Opening for Cabinet 2
VA304	S	Number of Winner (Free) Vends (I)	EA104	S	Minutes of Opening Cabinet 2
CA302	S	Value of Cash to Cashbox (I)			
CA304	S	Number of Bills to Stacker (I)	PA101	S	Cabinet 1 Header
CA306	S	Value of Cash to Cashbox (H)	PA201	S	Number of Vends for Cabinet 1 (H)
CA308	S	Number of Bills to Stacker (H)	PA202	S	Value of Vends for Cabinet 1 (H)
CA701	S	Value of Cash Discounts (I)	PA203	S	Number of Vends for Cabinet 1 (I)
CA702	S	Value of Cash Discounts (H)	PA204	S	Value of Vends for Cabinet 1 (I)
DA201	S	Value of Card Vends (H)			
DA203	S	Value of Card Vends (I)	PA101	S	Cabinet 2 Header
EA201	S	Number of MIS Resets Header	PA201	S	Number of Vends for Cabinet 2 (H)
EA203	S	Number of MIS Resets (H)	PA202	S	Value of Vends for Cabinet 2 (H)
EA201	S	Number of Machine Resets Header	PA203	S	Number of Vends for Cabinet 2 (I)
EA203	S	Number of Machine Resets (H)	PA204	S	Value of Vends for Cabinet 2 (I)
MA501	S	Value of Coins in Tubes Header			
MA502	S	Value of Coins in Tubes	PA101	F	Selection Number 110 Header
MA501	S	# of Discounted Vends Header	PA102	F	Product Price Delection # 110
MA502	S	Number of Discounted Vends (H)	PA103	F	Product Code for Selection # 110
MA503	S	Number of Discounted Vends (I)	PA104	F	Spiral Count for Selection # 110
MA501	S	\$ of Disc for Combo Vends Header	PA201	F	# of Vends Selection # 110 (H)
MA502	S	\$ of Discount for Combo Vends (H)	PA202	F	Value Vends Selection # 110 (H)
MA503	S	Number of Combo Vends (H)	PA203	F	# of Vends for Selection # 110 (I)
MA504	S	Value of Dicounted Vend/s (I)	PA204	F	Value Vends for Selection # 110 (I)
MA505	S	Number of Combo Vends (I)	EA101	F	Time of Last Vend Selection # 110
EA101	S	Last Defrost Date for Cab 1 Header	EA102	F	YYMMDD Last Vend Sel # 110
EA102	S	YYMMDD of Last Defrost, Cab 1	EA103	F	HHMM Last Vend Selection # 110
EA 103	S	HHMM of Last Defrost for Cab 1			
EA 101	S	Last Defrost Date for Cab 2 Header			
EA102	S	YYMMDD of Last Defrost Cab 2			
EA103	S	HHMM of Last Defrost for Cab 2			

Note: PA101-EA103 is repeated for each selection.

M I S MENU	SETUP MENU	CONFIGURATION MENU	DIAGNOSTIC MENU	SECURITY MENU	TIME FUNCTIONS	PRICE MENU	DISPLAY MENU
------------	------------	--------------------	-----------------	---------------	----------------	------------	--------------

Display

CLEAR MIS DATA - N Pressing the + key to toggle the N (no) to Y (yes) then press ENTER will reset the interval MIS data. It will also increase the MIS reset field by 1 reset each time a reset is done.

TUBE FILL

Allows you to fill the coin mech and the logic board will count the money as it goes in and continually track the coin mech inventory. This is the count the board uses when you choose tube leveling as a Payout type in the Setup menu heading.

NOTE: It is not necessary to fill the coin mech in this mode unless you have changed to tube leveling. To proceed press ENTER

TO = 00.00 (XX.XX

TO is the tube # of the last coin inserted (1-4, 0 for a non tube coin)
 00.00 is the value of the coins in the tube shown.
 XX.XX is the value of coins in all tubes.

SOFTWARE REVISION

Press ENTER

P030 L04.00 C117 C217

P030 is the software version of the Microprocessor on the logic board. (large chip).
 L04.00 is the software version of the Flash Memory chip on the logic board. (small chip).
 C117 is the software version of the Flash Memory chip on the Food Driver Board (small chip) in cabinet 1.
 C217 is the software version of the Flash Memory chip on the Food Driver Board (small chip) in cabinet 2.

SETUP VIEW MIS HTOT SALES - Y

Press ENTER and the display will prompt you with the first viewable MIS item:
 Use the < or > key to scroll through the list of viewable MIS items. Press the + key to toggle the Y (yes) to (no) to N (no) if you do not want the item shown to be viewed in the View MIS Menu.
 When you have finished making changes press ENTER for the changes to take effect.

The MIS data is incremented as follows:

Field	Vend Type						
	Normal	Discount Winner	Token or Winner	Discount & Winner or Token	Combo	Testvend	Freevend
#VENDS	•	•	•	•	•		•
\$VENDS (Sale Price)	•	•	0	0	•		0
#/PROD	•	•	•	•	•		•
\$/PROD (Sale Price)	•	•	0	0	•		0
#/TESTVEND						•	
#/DISCOUNT		•		•			•
\$/DISCOUNT (Amount)		•		•			• (List)
#/WINNER			•	•			
\$/WINNER (Sale Price)			•	•			
#/COMBO					•		
\$/COMBO (Discount)					•		

- Indicates which field is updated for a given vend type.

(List Price - Discount Amount if any = Sale Price)

Note: \$Winner accumulates sale prices of Winners. If the Winner is also Discounted, the vend is counted in #Discount and the discount is accumulated in \$Discount.

setup menu heading

The Setup Menu heading contains all the Setup Menu Items in the machine.

Pressing ENTER when the display indicates Setup will cause the display to be updated with Bill Escrow.

Use the < or > arrow keys to scroll through the following menu items:

Bill Escrow Free Vend Winner Vend Multiple Vend Force Vend Combo Vend Max Payout Set Payout Type

Pressing ENTER when any of the above items are on the display will give you access to that Menu Item.

Below is a detailed list of each of the above Menu Items:

Display

- BILL ESCROW - N** Use the + or – key to change between N, FIRST or LAST. Press ENTER to commit to any changes.
N - Disables bill escrow and all bills will be stacked. Pressing the coin return the customer will receive all change.
First - Holds the first bill in escrow and pressing the coin return will return the bill.
(All other money added will need to be coin).
Last - The machine will accept bills to the highest vend price, pressing the coin return will return the last bill and all other bills inserted will be returned in change.
Note: Force vend overrides bill escrow.
-
- FREE VEND-N** Use the + or – key to change between N (no) and Y (yes). Press ENTER to commit to any changes. When Free vend is set to yes the display will prompt "ALL ITEMS ARE FREE" unless overridden by a custom point of sale message.
-
- WINNER VEND -OFF** To turn on Winner vend, enter a number between 1 and 500 using the selection key pad or the + and – keys. Off is between 1 and 500. Press ENTER to commit to changes. When a customer wins an item, credit will be returned to the customer and the display will indicate ***WINNER***. Note: When a machine is set to free vend, test vend or the second vend of a combo vend are not counted for the purposes of determining a winner.
-
- MULTIPLE VEND-N** Use the + or – key to change between N (no) and Y (yes). Press ENTER to commit to any changes. If you choose Y the display will prompt:
- TIMEOUT - 20** This is the amount of time the customer has to make another selection before their change is returned. During this time period the customer can make a selection, add more money to make another selection or press the coin return to receive their change. If the change due back is less than the lowest priced item in the machine, change will be returned immediately. This time period is settable from Five to Ninety seconds. To change the time use the selection key pad or the + and – keys. Press ENTER to commit to the time period.
-
- FORCE VEND - N** Use the + or – key to change between N (no) and Y (yes). Press ENTER to commit to any changes. When Force vend is turned on, once there is enough credit established to purchase the lowest priced item in the machine, the customer must make a purchase.
Note: Force vend overrides bill escrow and does not apply when debit cards are used.
-
- COMBO VEND - N** Use the + or – key to change between N (no) and Y (yes). Press ENTER to enter the combo vend menu item.
- TIMEOUT - 20** This is the amount of time the customer has to add more money and/or make the second selection of a combo vend. This time period is settable from Five to Ninety seconds. To change the time use the selection key pad or the + and – keys. Press ENTER to commit to the time period.
- 01XXX-YYY FREE N** Use the < or > to move the flashing cursor between the fields.
01 is the combo #. Use the + or – key to scroll through the combo #, a maximum of ten is supported
XXX-YYY - XXX is the item selected by the customer, YYY is the item to be vended in combination with the customer-selected item.
Free is the discounted price of YYY when selected after XXX is selected. Any price can be set for the second item including free. To set the price use the selection key pad or the + and – keys. Free is located below 00.05 cents.
N - Use the + or – key to toggle between N (not active) and Y (active). This allows you to program in combo vends and turn them on and off as desired.

MAX PAYOUT - N Use the + or – key to change between N (no) and Y (yes). Press ENTER to commit to any changes.

MAX PAYOUT - 01.00 When to choose Y the display will show the maximum amount of money to be paid back after a vend. To change the Maximum payback amount use the selection key pad or the + and – keys. Press ENTER to commit to the Maximum payback amount.

PAYOUT - LEVELING There are 3 payback options are fewest, MDB level 3 and leveling. Use the + or – key to change between the 3 different options. Press ENTER to commit to a payback option. Here is a discription of the three payback options:

Fewest - This option is the factory default and will always payback the least number of coins available based on the sensors in the coin mech.

Leveling - The board makes all the payback decisions based on how much money it thinks is in each tube. When using this option it is important that you teach the board how much money is in the coin mech (use "Tube fill" menu item) when you set up the machine.

MDB Level 3 - The changer makes all the pay back decisions based up how much money it thinks is in the tubes. This option will only work with MDB coin mechs. All payback options will work with MDB also, you are not limited to this option with MBB coin mechs.

configuration menu heading

The Configuration Menu heading contains all the Configuration Menu Items in the machine.

Pressing ENTER when the display indicates Configuration will cause the display to be updated with Motor Pairs.

Use the < or > arrow keys to scroll through the following menu items:

Motor Pairs	Configure Load	Set Temperature	Set Function Keys	Spiral Count	Setup Printer
Set Lockout	Set Free Coupon	Set Defrost	Speech Enable		

Pressing ENTER when any of the above items are on the display will give you access to that Menu Item.

Below is a detailed list of each of the above Menu Items:

Display

MOTOR PAIRS Allows you to pair any even numbered motor may be paired with the odd numbered motor next in sequence.

PAIR MOTOR NO N To pair motors Press the > one time this will cause the N (no) to start flashing. Press the + key, this will change the N to Y (yes). Press the < one time this will cause the last digit in the selection number to start flashing. Key in on the selection pad the selections to be paired. After each selection number that is keyed in you will here a beep. The beep indicates that the selection number has been accepted. Pressing C\CE at any time will clear the display as if it were a backspace key. To remove motor pairs follow the same procedure but key in the selections with the state of the motor set to N (no).

CONFIGURATION LOAD Allows the uploading or downloading of information to or from the logic board. Press ENTER and the display will prompt MasterMenu online. Use the + or – key to scroll through the following options:

MasterMenu Online - is software that allows you to program a machine with a Personal Computer. See the options section of this manual for more information.

TMU Upload - allows you to upload programing information to a machine for a touch memory button (chip) that has already been programed.

TMU Download - allows you to download programing information to a touch memory button (Chip), for more information on chip see the options section of this manual.

Press ENTER to start the upload or download process. Upon completion the display will prompt that the download is complete. If the information can't be transferred the display will prompt transfer error or transfer disconnect.

SET TEMPERATURE CAB1 AMBIENT --- F Press ENTER, the display will prompt:

Cab1 (Cabinet 1) - Use the + or – to change between cab1 and cab 2 (cabinet 2). Use the > to move the flashing digit to Ambient. Use the + or – to change between:

Ambient (outside air temperature)

Food - the target temperature (---) will automatically change to of +36 degrees Fahrenheit. The temperature is not adjustable when set to food.

Frozen - the target temperature (---) will automatically change to of + 10 Fahrenheit. Use the + or – to change between + 10 and –15 Fahrenheit.

Chilled - (Appears only when cabinet 1 is a snack or 128/129 Cabinet) the target temperature (---) will automatically change to of + 70 Farenheit. Use the + or - to change between + 70 and +40 Farenheit.

F = Fahrenheit, use the + or – to change between F and C (Celsius)

Press ENTER to commit to a temperature setting.

M I S MENU	SETUP MENU	CONFIGURATION MENU	DIAGNOSTIC MENU	SECURITY MENU	TIME FUNCTIONS	PRICE MENU	DISPLAY MENU
------------	------------	--------------------	-----------------	---------------	----------------	------------	--------------

SET FUNCTION KEYS Allows you to change the function keys F1-F7 or F1-*F7 to any of 30 pre defined function keys. Press ENTER and the display will prompt:

F1 - MIS Use the < or > to move the between the function key and the Menu Item.
Use the + or – to change the function key or menu item assigned to that key.
Press ENTER to commit to any changes.

Note: Function keys can be reset to the factory defaults in the machine reset menu item.

The pre-defined functions available for assignment are:

Function	Initial Function Key
VIEW HISTORICAL MIS	F1
VIEW ERRORS	F2
CLEAR ERRORS	F3
SET PRICE	F4
CHECK PRICE	F5
TEST VEND	F6
TUBE FILL	F7
MOTOR PAIRS	*F1
SET TEMPERATURE	*F2
SET TIME & DATE	*F3
BILL ESCROW	*F4
BAFFLE DOOR TEST	*F5
TRASMIT MIS	*F6
SETUP DEFROST	*F7
WINNER VEND	OPEN
MULTI VEND	OPEN
COMBO VEND	OPEN
SET MAX PAYOUT	OPEN
SET PAYOUT TYPE	OPEN
SET LOCKOUT	OPEN
CONFIGURE LOAD	OPEN
MOTOR TEST	OPEN
DISCOUNT DAY / TIME	OPEN
DISCOUNT OPTIONS	OPEN
SHUTDOWN DAY / TIME	OPEN
SHUTDOWN OPTIONS	OPEN
SET USER MESSAGES	OPEN
OUT OF SERVICE MESSAGE	OPEN
AFTER SALE MESSAGE	OPEN
SET SCROLLING	OPEN
SET MENU ORDER	OPEN
SERIAL NUMBER	OPEN

configuration menu heading

SET SPIRAL COUNT - N

This menu allows you program the number of spaces in each spiral. When a selection has vended all the product out of and individual spiral the machine will prompt make another selection and will beep 6 times. When the Set Spiral count is enabled and the door is opened to service the machine the display will prompt "Stock Machine N?", to reset the spiral count toggle the N to Y and press ENTER. Note: you must fill all selections each time you service the machine, change the spiral count or turn off spiral count for each selection not being completely filled to work properly.

This menu was implemented for locations with visually impaired customers. Some operators have also used this menu when vending high priced items.

Use the + or – key to change between N (no) and Y (yes). Press ENTER to commit to any changes. When Spiral Count is set to yes the display will prompt:

SPIRAL 110 00 N

Press the > two times to N (no)

Press the + or – key one time to Y (yes)

Press < one time to 00 (spiral count)

Use the selection buttons to key in the desired count.

Press < one time to 110 (selection number)

Using the selection buttons, enter the selections to be set for the spiral count shown.

Repeat the above process for all additional spiral counts to be set.

SETUP PRINTER BAUD - 9600 N81

Press ENTER to change the baud rate, parity, data, and stop bits.

Use the < or > key to scroll through baud rate, parity, data, and stop bits. Press the + or – key to change the flashing digit.

The available parameters are:

Baud rate	300	1200	2400	6900	19200
Parity	None (N)	Even (E)		Odd (O)	
Data Bits	Eight (8)		Seven (7)		
Stop Bits	One (1)	Two (2)			

SET LOCKOUT -N

Allows you to lock out specific selections when an external key switch is activated.

To enter lockout menu:

Press the > one time to N (no)

Press the + or - key one time to Y (yes)

Press ENTER and the display will prompt:

LOCKOUT SEL 110 N

Press the > one time to N (no)

Press the + or - key one time to Y (yes)

Press < one time to 110 (selection number)

Use the selection buttons to key in the selections to be locked out when the external key switch is activated. **Note: Wild Cards can be used when entering selections.**

SET FREE COUPON - N SEL 100 N

Use the + or – key to change between N (no) and Y (yes) and press ENTER the display will prompt:

Press the > one time to N (no)

Press the + or - key one time to Y (yes)

Press < one time to 100 (selection number)

Use the selection buttons to key in the selections to be free when a coupon is used.

Note: Wild Cards can be used when entering selections.

M I S MENU	SETUP MENU	CONFIGURATION MENU	DIAGNOSTIC MENU	SECURITY MENU	TIME FUNCTIONS	PRICE MENU	DISPLAY MENU
------------	------------	--------------------	-----------------	---------------	----------------	------------	--------------

SET DEFROST
CAB 1 00:00 AT 6HRS

Allows you to customize target defrost time for cabinets 1 and 2. It is not necessary to set this menu it is a target defrost time only. Press ENTER and the display will prompt:
Press the + or – key to change the flashing digit. Use the < or > key to scroll through the following:
Cab1 - Use the + or – key to Toggle between Cab1 (cabinet 1) and Cab2 (cabinet 2).
00:00 (midnight) - Is the target time for the defrost cycle. Use the + or – key or the selection key pad to change the target time for the defrost cycle.
6hrs - This is the amount of time between defrosts. Use the + or - key to toggle between 6 hours and 8 hours.
Note: Pressing F2 on the keypad will initiate a manual defrost for the cabinet currently being displayed.

SPEECH SYNTHESIS - N

Use the + or – key to change between N (no) and Y (yes). When Y is chosen a Voice Synthesizer can be connected to the DEX/UCS port. The Voice Synthesizer will echo the display while in the service mode.
Note: When Speech Synthesis is enabled, the DEX/UCS port can no longer be used for any other communications.

SET GOLDEN EYE - N

Use the + or – key to change between N (no) and Y (yes). Pressing Enter when the Y is flashing will enable Golden Eye®.
The Display will Prompt: GOLDENEYE SEL 110 N
Press the > one time this will cause the N (no) start flashing.
Press the + key, this will change the N to Y (yes).
Press the < one time this will cause the last digit in the selection number to start flashing.
Key in on the selection pad the selection to set to work with Golden Eye®. After each selection number that is keyed in you will here a beep. The beep indicates that the selection number has been accepted. Pressing C\CE at any time will clear the display as if it were a backspace key.
Note: Pressing 1** will enable Golden Eye® for the entire machine.
To remove selection from working with Golden Eye® follow the same procedure but key in the selections with the state of the motor set to N (no).

diagnostic menu heading

The Diagnostic Menu heading contains all the self-diagnostic capabilities of the machine.

Pressing ENTER when the display indicates Diagnostics will cause the display to be updated with View Errors.

Use the < or > arrow keys to scroll through the following menu items:

View Errors Clear Errors Test Vend Test Motors Test Baffle Door

Pressing ENTER when any of the above items are on the display will give you access to that Menu Item.

Below is a detailed list of each of the above Menu Items:

Display

VIEW ERRORS

Pressing ENTER to will cause the first of any pending errors to be displayed. Use the < or > to sequence through the error list. Pressing F2 when viewing any error will cause the time and the date the error occurred to be shown on the display.

The following lists the possible error codes;

- MOTOR XYZ STALLED
- MOTOR XYZ STUCK HOME
- MOTOR XYZ DIDNT HOME
- MOTOR XYZ OFF HOME
- MOTOR XYZ MISSING
- CAB X DEFROST ERROR
- BAFFLE X CURRENT
- BAFFLE X TIMEOUT
- HEALTH SHUTDN CAB X

CLEAR ERRORS - N

Use the + or – key to change between N (no) and Y (yes). Pressing ENTER, when set to Y will cause all errors to be cleared.

TEST VEND - N

Use the + or – key to change between N (no) and Y (yes). Pressing ENTER, when set to Y will cause the display to prompt:

TEST VEND ACTIVE

The Selection buttons will become active allowing test vends. Closing the door will automatically turn Test Vend off.

TEST MOTORS

TEST MOTOR - 110

Press ENTER will prompt:

Key in any selection number to be tested. To test the entire cabinet key in 1** for cabinet 1, or 2** for cabinet 2. The test will show Motor XXX Passed /Failed for 3 seconds for every selection tested. This is a motor detection test and does not vend the motor.

TEST BAFFLE DOORS

OPEN DOOR - CAB1

Pressing ENTER will cause the display to prompt:

Use the < or > arrow to move between Open Door and Cab1.

Open Door - Use the + or – to toggle between open door and close door.

Cab1 - Use the + or – to toggle between Cab1 (cabinet 1) and Cab2 (cabinet 2).

Pressing ENTER will cause the baffle door to perform the test shown on the display.

security menu heading

Pressing ENTER when the display indicates Security will cause the display to be updated with Machine ID.

Use the < or > arrow keys to scroll through the following menu items:

Machine ID Serial Number Password Definition Password Prompt Set Security Levels
Set Product Codes Machine Reset

Pressing ENTER when any of the above items are on the display will give you access to that Menu Item.

Below is a detailed list of each of the above Menu Items:

Display

MACHINE ID 1234567890	Press ENTER to assign a machine ID number. Use the selection keypad to enter a Machine ID number up to 10 digits long. Press ENTER to commit to any changes.
SERIAL NUMBER 0987654321	Press ENTER to assign a machine Serial number. Use the selection key pad to enter a Serial number up to 10 digits long. Press ENTER to commit to any changes.
PASSWORD DEFINITION	The four levels of security they are: SuperUser - highest security level Level 1 - SuperUser and level 1 have access Level 2 - SuperUser , level 1 and level 2 have access Level 3 - this is the lowest level of security and no password can be assigned. Press ENTER to change the factory passwords to custom passwords. The display will Prompt:
PASSWORD 2 2222	Use the < or > arrow to move between the security level and the password. The + or – key will toggle the flashing digit or use the selection keypad to change the numeric digits. Press ENTER to commit to the password for the security level shown on the display.
PASSWORD PROMPT - N	Use the + or – key to change between N (no) and Y (yes). Pressing ENTER, when set to Y will cause the password prompt to be displayed as soon as the user attempts to press ENTER. If the password prompt is set to N (no) and menu items have been assigned security levels, the user must know to press ENTER, then escape to get the password prompt to appear on the display.
SET SECURITY LEVEL - N	This menu allows you to set a Security Level for each Menu Heading and Menu Item. Note: Setting a Menu Heading to a Security Level will also hide all Menu Items under the Menu Heading. The four levels of security they are: SuperUser (S) - highest security level. Level 1 - SuperUser and level 1 have access. Level 2 - SuperUser, level 1 and level 2 have access. Level 3 - this is the lowest level of security and no password can be assigned. Use the + or – key to change between N (no) and Y (yes). Pressing ENTER, when set to Y will cause the display to prompt:
MIS 3	MIS - Is the first Menu heading. Use the < or > to scroll through the Menu Headings and Menu Items. 3 - is the current security level for the Menu Heading or Menu Item shown on the display. Use the + or – keys to change the security level. Press ENTER to commit to security level changes.
FACTORY TEST - N	Use the + or – key to change N (no) to Y (yes) & press ENTER to test all spirals in the machine. The machine will begin to vend all spirals in sequence. If a motor is not present or bad the machine will beep three times and display the bad motor. To continue with the test press ENTER.
PRODUCT CODES - MANUAL	This menu allows you to choose the format the DEX/UCS information is transferred. Use the + or – key to change between MANUAL & AUTO, press ENTER to Set. MANUAL - The DEX/UCS information is transferred by Product Code. Product Codes can be assigned to a selection or number of selections. See Price setting instructions for details on manually setting product codes. AUTO - The DEX/UCS information is transferred by selection (How many times each selection was vended).
MACHINE RESET - N	This menu allows you to reset the machine. The Four Reset options are as follows: Messages - Resets all messages back to factory defaults. Options - Resets all set up options to factory defaults. MIS Data - Resets all MIS (accountability) data, interval and historical to zero. F Keys - Resets all the function keys F1-F7 and *F1-*F7 to factory defaults. All - Resets the entire board to the factory defaults of software in the board. Use the + or – key to change between N (no) and Y (yes). Pressing ENTER, when set to Y will cause the display to prompt:
RESET - MIS	Use the + or – key to change between the five reset options. Press ENTER to commit to the reset option. The display will prompt:
ARE YOU SURE - N	Use the + or – key to change N (no) to Y (yes) & press ENTER to commit to a reset.

MIS MENU	SETUP MENU	CONFIGURATION MENU	DIAGNOSTIC MENU	SECURITY MENU	TIME FUNCTIONS	PRICE MENU	DISPLAY MENU
----------	------------	--------------------	-----------------	---------------	----------------	------------	--------------

time functions menu heading

The Time Functions Menu Heading contains all the programmable time functions in the machine.

Pressing ENTER when the display indicates Time function will cause the display to be updated with Set Discount Times.

Use the < or > arrow keys to scroll through the following menu items:

Set Discount Times Set Discount Options Set Time / Date Set Shutdown Times Set Shutdown Options

Pressing ENTER when any of the above items are on the display will give you access to that Menu Item.

Below is a detailed list of each of the above Menu Items:

Display

SET DISCOUNT TIMES
Disc 01 00:00-00:00

Press ENTER, the display will prompt:

Disc 01 is the Discount period. You can set up to 10 different Discount periods. The < or > arrow keys will change which digit is flashing and the + or – key will toggle the flashing digit.

00.00-00.00 is the time settings for the Discount. The number on the left is the time the Discount will start. The second number is the time the machine resumes normal pricing. 00.00 is midnight and all times must to be set in Military time. The times set can not be set to cross over midnight, if you are setting a machine to be Discount all night long you will need to set two Discount periods. Example: If a machine is to be Discounted from 7PM to 7AM the two Discount periods would be set as follows: Disc 01 19:00-23:59 Disc 02 00:00-07:00

"SMTWTFs"

Pressing ENTER when viewing a Discount will change the display to:

Uppercase letters indicate that the Discount will be active that day.

The < or > arrow keys will change which digit is flashing and the + or – key will toggle the flashing digit between uppercase and lowercase. Pressing ENTER will apply the days of the week as they are currently set on the display.

Example: sMTWTFs = Monday through Friday the machine will Discount, Saturday and Sunday the machine will not Discount.

When all discount times are set:

- Press ESC to Exit back to the Menu item Set Discount Times.
- Press the > key one time to:

SET DISCOUNT OPTIONS
DISCOUNT ITEMS 01 0.00 N

Press ENTER. The Display will prompt:

01 is referring to Discount period 1 programmed above.

0.00 is the amount of discount for all items selected for discount period 01 (example 0.05 will reduce a 0.50 cent item to 0.45 cents.

the N (no) or Y (yes) indicated the current status of Discount period 1. Use the + or - keys to toggle between N and Y. Press "ENTER" the display will prompt:

01 DISCOUNT - 110 N

Press the > one time to N (no)

Press < one time to 110 (selection number)

Use the selection buttons to key in the selections to be dicounted when the discount period above is activated. **Note: Wild Cards can be used when entering selections.**

SET TIME/DATE
13:10 18.JAN.00

Press Enter to set the time and date. The Display will prompt.
13:10 (1:10 PM) is the current time, all times are in military time.
18, Jan, 00 is the 18th day of January 2000.
 The < or > arrow keys will change which digit is flashing and the + or - key will toggle the flashing digit or use the selection keypad to change the numeric digits. Press ENTER to commit to the time shown on the display.

SET SHUTDOWN TIMES
SHUT 01 00:00-00:00"

Press ENTER, The display will prompt:
Shut 01 is the Shutdown period. You can set up to 10 different Shutdown periods. The < or > arrow keys will change which digit is flashing and the + or - key will toggle the flashing digit.
00.00-00.00 is the time settings for the Shutdown. The number on the left is the time the Shutdown will start and the machine will be disabled. The second number is the time the machine will turn back on. 00.00 is midnight and all times must to be set in Military time. The times set can not be set to cross over midnight, if you are setting a machine to be Shutdown all night long you will need to set two Shutdown periods.
 Example: If a machine is to be Shutdown from 7PM to 7AM the two Discount periods would be set as Follows: "SHUT 01 19:00-23:59 SHUT 02 00:00-07:00

SMTWTFSS

Pressing ENTER when viewing a Shutdown will change the display to:
 Upper case letters indicate that the Shutdown will be active that day.
 The < or > arrow keys will change which digit is flashing and the + or - key will toggle the flashing digit between uppercase and lowercase. Pressing ENTER will apply the days of the week as they are currently set on the display.
 Example: sMTWTFs = Monday through Friday the machine will Shutdown, Saturday and Sunday the machine will not Shutdown.

- When all Shutdown times are set:
- Press ESC to Exit back to the Menu item Set Shutdown Times.
 - Press the > key one time to:

SET SHUTDOWN OPTIONS
SHUTDOWN ITEMS 01 N

Press ENTER. The Display will prompt.
ITEMS 01 is referring to Shutdown period 1 programmed above.
 The N (no) or Y (yes) indicates the current status of Shutdown period 1. Use the + or - keys to toggle between N and Y. Press ENTER, the display will prompt:
Note: If you are in a school and want to turn off the Shutdown feature for the summer and leave the times programmed, you can do this by changing the current status to N.

01 SHUTDOWN -110 N

Press the > one time to N (no)
 Press the + or - key one time to Y (yes)
 Press < one time to 110 (selection number)
 Use the selection buttons to key in all selections to be shutdown for the shutdown period above.
Wild Cards can be used when entering selections.

NOTE: The Selections to be Shutdown must be selected for each Shutdown period.
 If all selections are to be Shutdown, the display will prompt machine not available until the time the machine is programmed to turn back on. If only specific selections are to be Shutdown the display will prompt Selections (Selection numbers) not available until whatever time it is programmed to turn back on.

price menu heading

The Price Menu Heading contains all the pricing functions in the machine.

Pressing ENTER when the display indicates Price will cause the display to be updated with Price Assignment.

Use the < or > arrow keys to scroll through the following menu items:

Price Assignment

Check Prices

Pressing ENTER when any of the above items are on the display will give you access to that Menu Item.

Below is a detailed list of each of the above Menu Items:

Display

PRICE ASSIGNMENT

110 00.50 001

Press ENTER to set prices, the display will prompt:

110 - is the selection number, 00.50 - is the price, 001- is the product code.

Press the > one time to price, use the selection buttons key in the price to be set.

Note: if you are using product codes press the > one more time to price, use the selection buttons key in the product code to be set.

Press the < back to the selection number, use the selection buttons key in selections to set at the price and product code shown.

Repeat the above process for all prices to be set.

CHECK PRICES

110 00.50 001

Press ENTER to check prices currently set the display will prompt:

Use the selection buttons to key in a selection number, the current price and product code will appear on the display.

The Display Menu Heading provides access to all the Display Menu Items in the machine.

Pressing ENTER when the display indicates Display will cause the display to be updated with Set Menu Order.

Use the < or > arrow keys to scroll through the following menu items:

Set Menu Order Alt Language Set User Messages Set Out of Service Message Set After Sale Message

Pressing ENTER when any of the above items are on the display will give you access to that Menu Item.

Below is a detailed list of each of the above Menu Items:

Display

-
- SET MENU ORDER** This menu allows you to change the order that the Menu Headings appear on the display. Press ENTER the display will prompt:
- MENU } - M15** Use the < or > keys to move between the Menu number and the Menu Heading. Use the + or – key to scroll through the available menus or to change the menu number. Press ENTER to commit to changes in the menu order.
-
- ALT LANGUAGE - N** This menu allows you to use an alternate language for all messages. Use the + or – key to toggle between Y and N.
N - indicates all messages will be shown in English.
Y - Indicates all messages will be shown in the alternate language programmed by MasterMenu Online.
Press ENTER to commit to any changes.
-
- SET USER MESSAGE** Use this menu to program up to three different user messages. Press ENTER and the display will prompt:
- POS-E EDIT** Use the < or > keys to move between the fields.
Use the + or – key to toggle between:
POS-F, POS-A, POS-B and POS-C.
POS-F stands for the factory message; this message is not changeable.
POS-A/B/C are the three messages that can be programmed.
Pressing the ENTER key when the display prompts POS-A Edit allows you to program message A. The display will prompt:
- USER MESSAGE # 1** **Note: this is a two step process, first you need to Edit (program) a message (s) then you need to set the message to be active.**
To Edit the current message:
Use the + or – keys to scroll through the Upper and Lower case letters, the numbers 0-9 and a number of special characters including a blank space. Use the <or> to move the flashing cursor to the left or right. Start your message by overwriting the current message (User Message #1). Pressing the INS (insert) key will allow you to insert a character to the left of the flashing digit. Pressing the Del (delete) key will delete the flashing character. When the message is complete press ENTER. There is no start or end character required. **Note: this message will be stored and must be set for the message to become active.**
- To Set a Message:**
- POS-A SET** Use the + or – key to toggle the display to the message to be set (F, A, B or C). Press the > one time and the T in the word edit will start flashing. Press the + or – key one tome and the word set will appear. Press ENTER and the POS message shown will be set.
Note: if the message contains more characters than can be shown on the display the display will scroll. If the message is shorter than the display and you still want it to scroll you need to add blank spaces to the end of the message until the message starts to run off the display.

M I S MENU	SETUP MENU	CONFIGURATION MENU	DIAGNOSTIC MENU	SECURITY MENU	TIME FUNCTIONS	PRICE MENU	DISPLAY MENU
------------	------------	--------------------	-----------------	---------------	----------------	------------	--------------

display menu heading

SET OUT OF SERVICE

This menu allows you to set an out of service message. The out of service message is added on to the end of the machines out of service message.
Press ENTER and the display will go blank with a flashing cursor.
Use the + or – keys to scroll through the Upper and Lower case letters, the numbers 0-9 and a number of special characters including a blank space. Use the <or> to move the flashing cursor to the left or right
Press ENTER and the Out of Service message shown will be set.

SET AFTER SALE MESSAGE

This menu allows you to set an After Sale Message. Start your message by overwriting the current message
(Thank You Very Much).

Press ENTER and the display will prompt:

THANK YOU VERY MUCH

Use the + or – keys to scroll through the upper and lower case letters, the numbers 0-9 and a number of special characters including a blank space. Use the <or> to move the flashing cursor to the left or right.

Press ENTER and the After Sale Message shown will be set.

M I S MENU	SETUP MENU	CONFIGURATION MENU	DIAGNOSTIC MENU	SECURITY MENU	TIME FUNCTIONS	PRICE MENU	DISPLAY MENU
------------	------------	--------------------	-----------------	---------------	----------------	------------	--------------

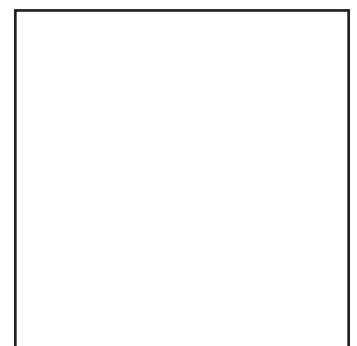
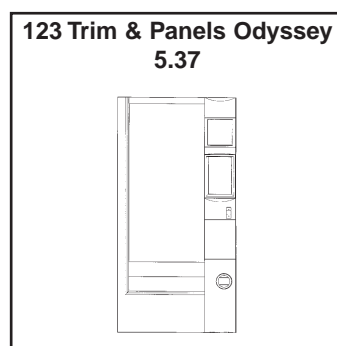
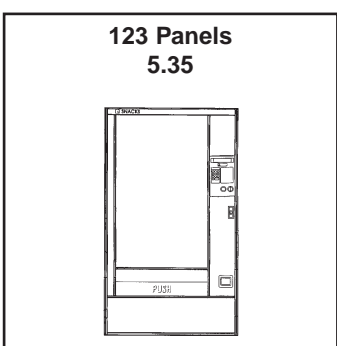
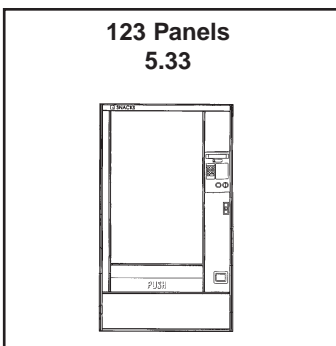
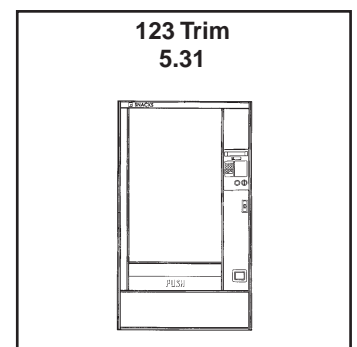
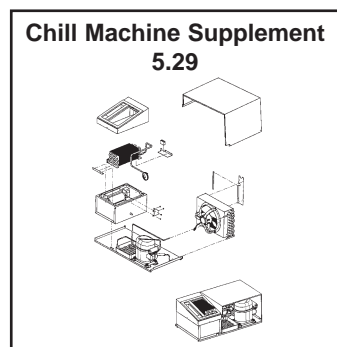
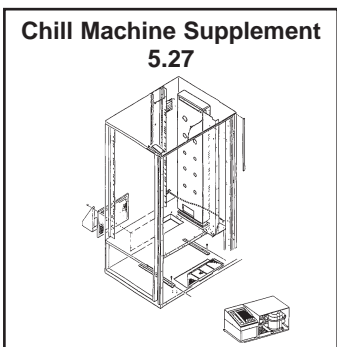
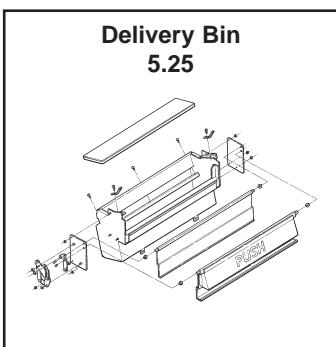
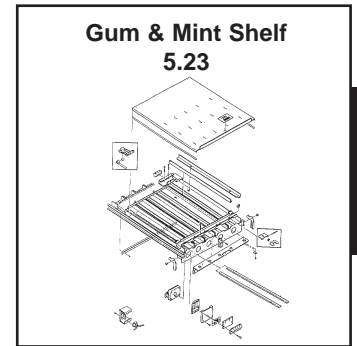
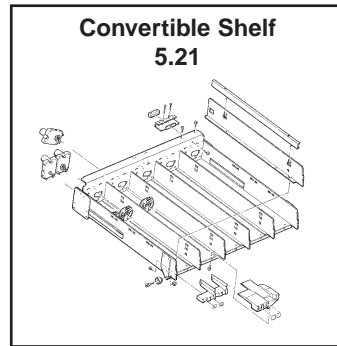
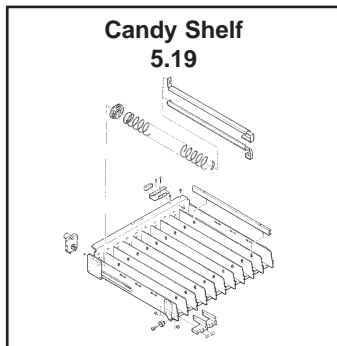
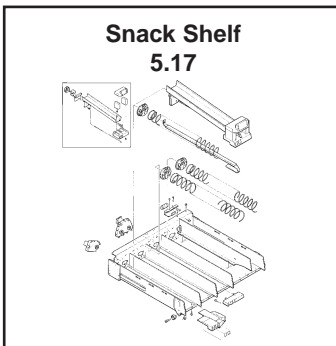
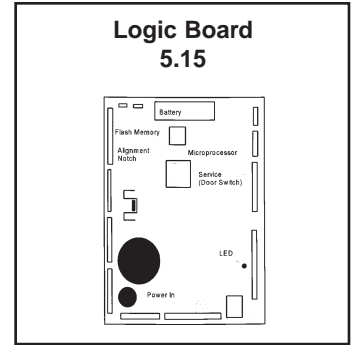
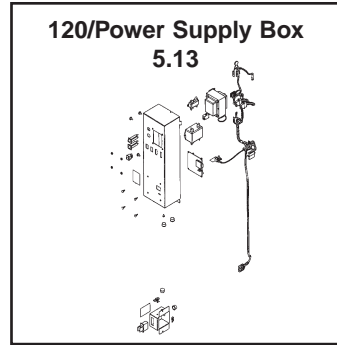
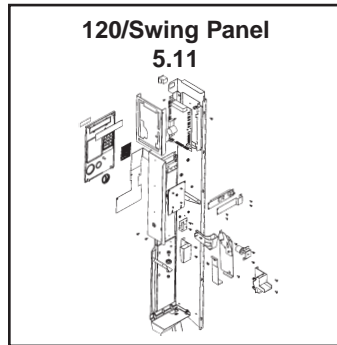
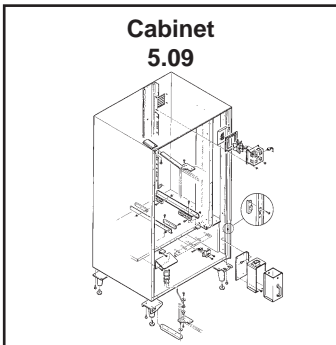
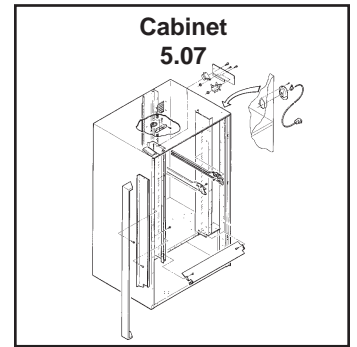
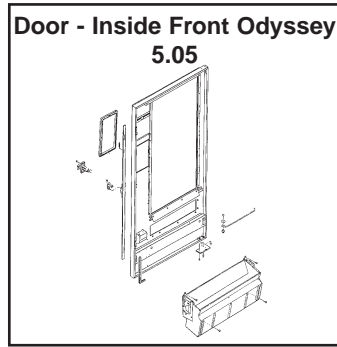
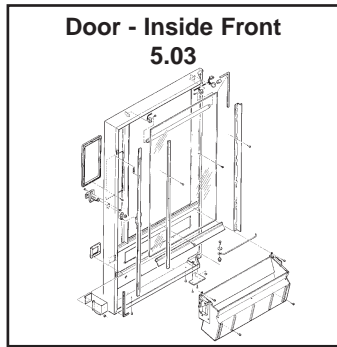
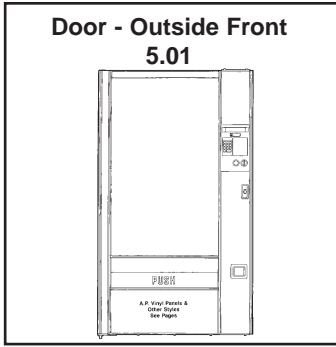

door - outside front

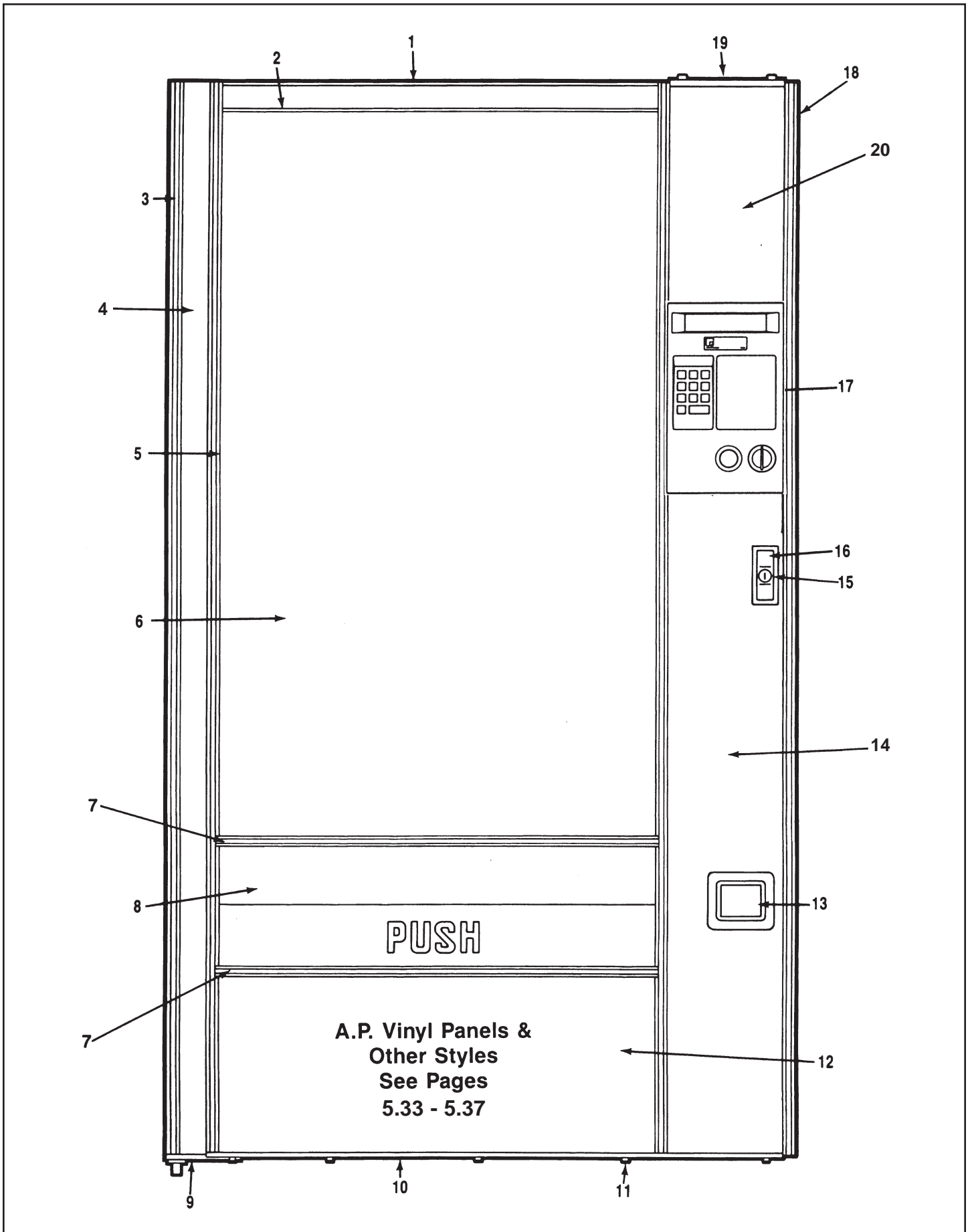

Item No.	Part No.	Description
1	340044-9	Top Trim Vantage
2	201690-2	Top Trim Insert, True Grit Black.
	201690-15	Top Trim Insert, Dark Gray.
3	340057-2	Trim Outside Vertical, Black, Right & Left.
4	202059-52	Panel, Left Side Vertical, Sterling Royce
	202059-48	Panel, Left Side Vertical, White.
	202059-50	Panel, Left Side Vertical, Dove Gray.
	202059-50	Panel, Left Side Vertical, Painted.
5	340058-46	Window Trim, Vertical, Black.
6	750141	Front Window (44 5/8 X 26 7/8 X 1/8). Note: Replacement Glass Must be Hard Tempered or Lexan Only.
	750141-8	Thermal Window, Optional (Can only be used on a machine ordered from the factory with a thermal window installed.
7	340058-5	Window Trim, Horizontal, Black.
8	201356-1	Deliver Tray Panel, True Grit Black.
	201356-43	Deliver Tray Panel, Dark Gray.
9	640154	Assembly, Lower Door Hinge Plate. Specify Color.
10	201678	Bottom Door Edging.
11	420186	Screw, Pan head
12	201692-1	Lower Horizontal Panel, Black.
	201692-56	Lower Horizontal Panel, Gray.
13	660581	Coin Cup Front Assembly, Black.
	660581-1	Coin Cup Front Assembly, Gray.
	201156	Coin Cup Door.
	440411	Coin Cup Trim Only, Black.
	440411-1	Coin Cup Trim Only, Gray.
14	202805-9	Panel, Right Side Vertical, Lower, Sterling Royce.
	202805-49	Panel, Right Side Vertical, Lower, White.
	202805-43	Panel, Right Side Vertical, Lower, Dove Gray.
	202805-15	Panel, Right Side Vertical, Lower, Painted.
15	420071	Ace Lock W/2 Keys.
16	16600254	Assembly, Lock Handle W Arm & Nut.
	17200002	Lock Handle Only.
17	440444-2	Bezel Ring, Black.
18	600810	Door Only, Specify Color.
	600811	Door Only, European Specify Color.
	600810-1	Door Only, with Validator and Card Reader Cut Out. Specify Color.
	600811-1	Door Only Euro With Validator and Card Reader Cut Out.
19	201678-6	Top Door Edging.

Item No.	Part No.	Description
20	202806-61	Panel, Right Side Vertical Upper, White.
	202806-55	Panel, Right Side Vertical Upper, Dove Gray.
	202806-19	Panel, Right Side Vertical Upper, Painted.
	202806-13	Panel, Right Side Vertical Upper, Sterling Royce.
	750202	Point of Sale Add ON Kit (Not Shown)

square & euro door - inside front

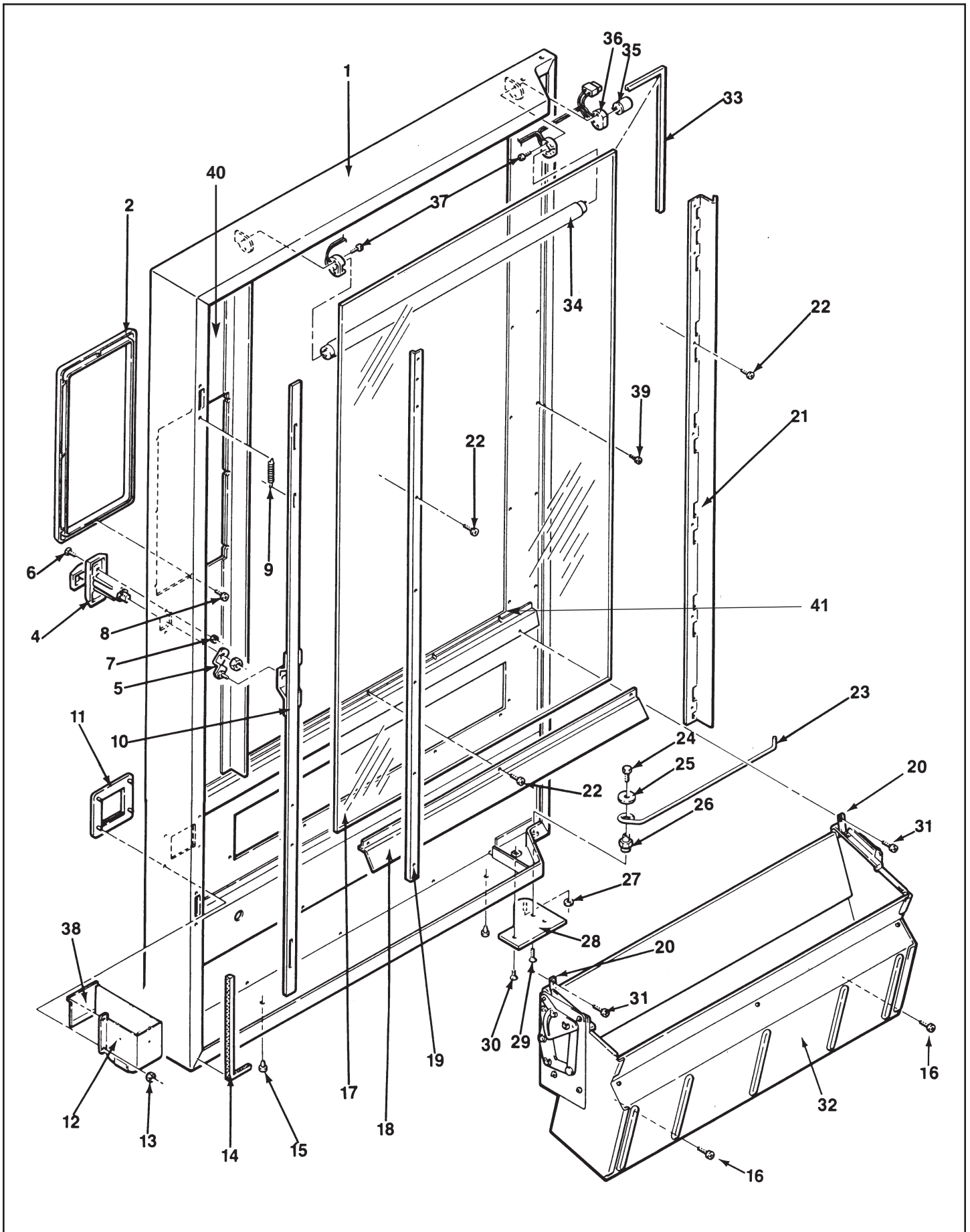

Item No.	Part No.	Description
1	600810 600811 600810-1 600811-1	Door Only. Specify Color. (Square) Door Only. European Style. Specify Color. Door Only. With Validator Hole And Debit Card Use. Specify Color. N/A at time of printing. Door Only European Style with Validator and Debit Card Hole
2	440444-2 440444-3	Trim Ring . Black. Bezel Ring. Gray.
4	660319 16600254 420146 17200002	T-Handle & Lock Arm Assembly. Chrome T-Handle & Lock Arm Assembly. Brushed T-Handle Only w/Nut. Chrome T-Handle Only w/Nut. Brushed
5	640131	T-Handle Lock Arm.
6	118-10-8	Carriage Bolt #10-24.
7	404-10	Nut, Hex #10-24.
8	116-6R4	Screw Pan HD. Phil. Type 23. #6-32x1/4.
9	400112	Lock Bar Spring.
10	600432-3	Lock Bar Assembly
11	440411 440411-1 660581 660581-1	Coin Cup Trim. Black. Coin Cup Trim. Gray Coin Cup Front Assembly, Black. Includes Trim, Door, Pin & Spring Coin Cup Front Assembly, Gray. Includes Trim, Door, Pin & Spring
	300212	Pivot Pin, Coin Cup Door Spring
12	202810 660863 202432 300184 276-8R6	Coin Return Cup Coin Return Cup with Stricker Striker, Door Switch Export Shoulder Bushing Export Screw, Pan HD Self Tap (8-32 X 3/8)(2) Spring, Striker Door Switch
13	420144	Ferrule.
13A	305-8R6	Screw
14	460041	Door Gasket Foam 1/4 x 1/4. 163" Required
15	420040-9	Hole plug.
16	276-8R6	Screw, Pan Hd. Phil. Type 23# 8-32x3/8.
17	750141 750141-8	Front Window. (44-5/8 x 26-7/8 x 1/8) NOTE: Replacement Glass Must Be Hard Tempered or Lexan Only. Thermal window, optional (can only be used on a machine ordered from the factory with a thermal window installed)

Item No.	Part No.	Description
	460570	Decal. "COOL - COOL" (not shown).
18	201384	Bottom Window Clamp.
19	202118	Window Clamp. Lock Side.
	12000056	Thermal Window Clamp
20	200906	Bin Anchor Strap.
21	201381-3	Shield & Window Clamp. Pivot Side.
22	201-6R11	ScrewRD. HD. Phillips Type B #6 x 11/16.
23	400090	Door Stop.
	400192	Chilled Machine Door Stop
24	114-41-8	Screw Hex. HD. Cap 1/4-20 x 1/ 2.
25	420010-10	Washer 1 1/8 OD.
26	300156	Door Stop Anchor.
27	420010-18	Washer, Brass (Door Adjustment).
28	640154	Lower Door Hinge Plate Assembly. Specify Color.
29	420003	Flat Head Socket Screw. 3/4 Lg.
30	420003-1	Flat Head Socket Screw. 1/2 Lg.
31	217-8R10	Screw. Pan Head, Phillips Type B #8 x 5/8.
32		Delivery Bin . Assembly Complete. See Page #5.25 For Itemized Parts.
	33a	460436 Window Edging (Order Per Inches). 143 Total.
	33b	13300007 Thermal Window Edging.
34	380022-5	Fluorescent Lamp F18T8/CWK24.
	380023-4	Starter FSII 240 volt
35	380023	Starter FS-25.
36	680512	Lamp Harness Assembly.
37	420062-1	Screw Round Head Slot Mach. #4-36 x 3/4.
38	440412	Coin Cup Door.
39	2016R7	Trim Screws. Screw Rd. Hd. Phillips Type A (6-18 x 3/8).
	200-6R6	Trim Screws. Screw Rd. Hd. Phillips Type A (6-18 x 3/8).
40	460756	Decal Function Keys
41	300206	Window Screw

odyssey door - inside front

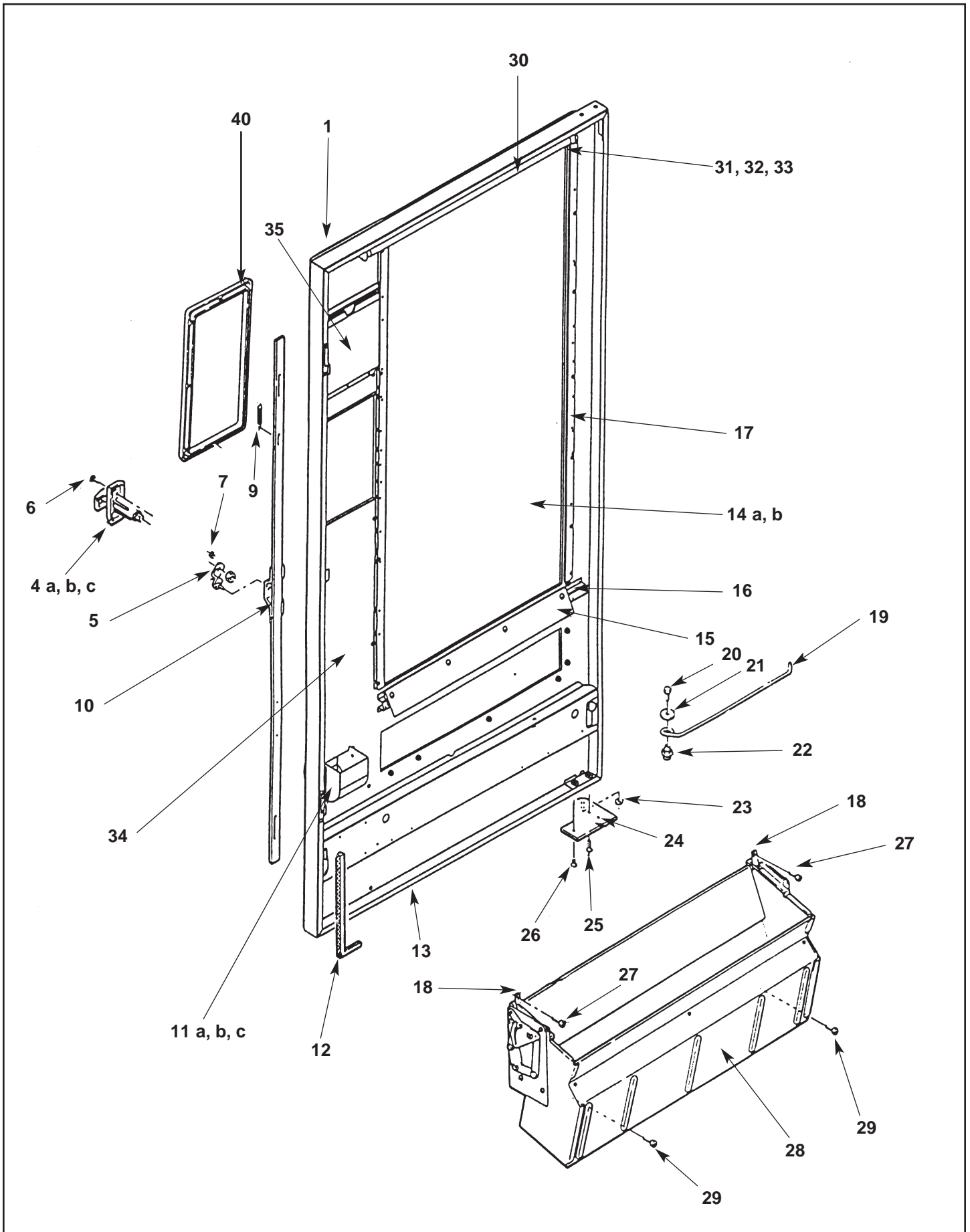

odyssey door - inside front

Item No.	Part No.	Description
1	16000043	Door Only, Odyssey
	1600043-01	Thermal Door Only
2	38527	Trim Ring, Odyssey
4a	16600114	T Handle and Lock arm Assembly (includes 4a, 4b, & 5)
4b	38332-1	T Handle only w/Nut
4c	22000190	Spacer, T Handle
5	16400012	T Handle Lock Arm
6	118-10-8	Carriage Bolt #10-24
7	404-10	Nut Hex, #10-24
9	400112	Lock Bar Spring
10	16000093	Lock Bar Assembly
11a	16000051	Coin Cup
11b	38529	Coin Cup Door
11c	38530	Coin Cup Axle Pin
12	460041	Door Gasket Foam 1/4 X 1/4
13	420040-9	Hole Plug
14a	750141	Front Window (44 5/8 X 26 7/8 X 1/8) Note: Replacement Glass Must be Hard Tempered or Lexan Only.
	14500003	Thermal Window, Optional (can only be used on a machine ordered from the factory with a thermal window installed.
	460570	Decal. "COOL - COOL" (not shown)
14b	460436	Window Edging (Order Per Inches) 143 Total
15	202461	Bottom Window Clamp.
	12000086	Bottom Window Clamp Thermal
16	202462	Lower Window Support
17	12000193	Vertical Window Clamp (Lock and Pivot Side)
18	200906	Bin Anchor Strap
19	400090	Door Stop
20	114-41-8	Screw Hex Head, 1/4 - 20 X 1/2
21	420010-10	Washer, 1 1/8 OD.

Item No.	Part No.	Description
22	300156	Door Stop Anchor
23	420010-18	Washer, Brass (Door Adjustment)
24	640154	Lower Hinge Plate Assembly. Specify Color.
25	420003	Flat Head Socket Screw, 1/4 Lg.
26	420003-1	Flat Head Socket Screw, 1/2 Lg.
27	217-8R10	Screw, Pan Head, Phillips #8 X 5/8
28		Delivery Bin, Assembly Complete See Page 5.25 For Itemized Parts.
29	276-8R6	Screw Pan Hd. 8-32 x 3/8
30	380022-5	Fluorescent Lamp, F18T8/CWK24
31	380023	Starter FS25
	380023-3	Starter, 240 Volt
32	680512	Lamp Harness Assembly
33	420062-1	Screw, Flat Head Machine, #8-36 x 3/4
34	460756	Decal, Function Keys (Not Shown)
35	16600111	POS Assembly Complete
35A	12000201	POS Theft Guard
36	305-7R8	Screw, Plastite, #7 x 1/2
37	276-6R4	Screw, Self Tap, 6-32 x 1/4
38	438-8	Nut, 8-32
39	420144	Ferrule
40A	350-8R6	Ferule Screw, Plastite, #8 x 3/8
40B	38527	Bezel Coin Insert

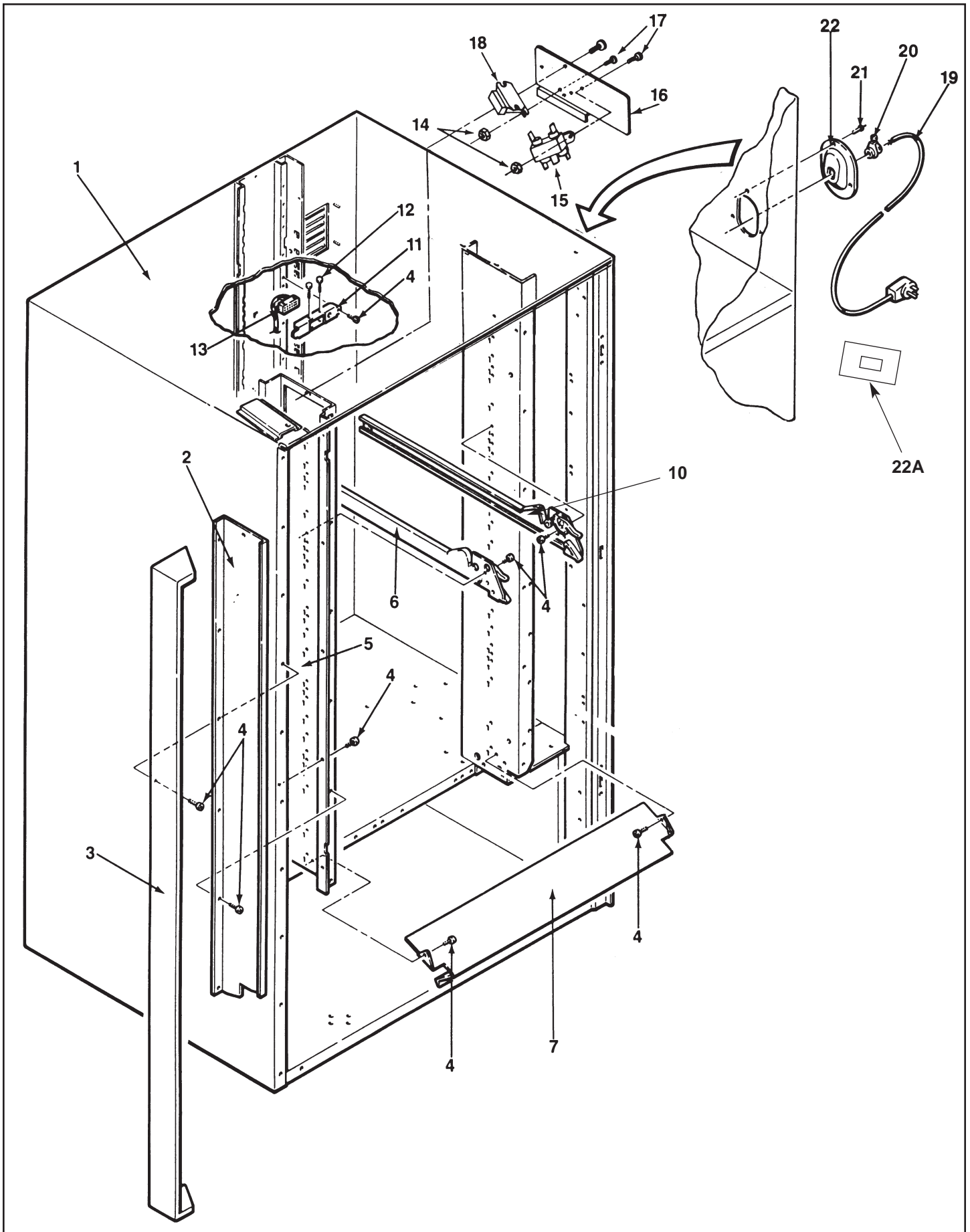

Key	Description	123 Below Serial # 12399090000	123A Between Serial #'s 123A99090000 123A01042200	123B Above Serial # 123B01043000	123C Above Serial# 123C02xxxxxx
1	Cabinet Assembly Complete, with Legs. Specify Color. (123)	750100-5	750101-10	750101-10	17500025-02
	Chilled Machine Cabinet Assembly Complete, with Legs. Specify Color. (123)	N/A	750101-13	750101-13	17500025-07
	Cabinet Assembly Complete, with Legs. Specify Color. (124)	N/A	750101-16	N/A	N/A
2	Filler Plate, Left Front.	202821	202821	202821	12000246
3	Door Filler, Specify Color.	600310	600310	600310	600310
4	Screw Pan Head, (8-32 X 3/8)	276-8R6	276-8R6	276-8R6	276-8R6
5	Shelf Support, Front Left	202120	12000062	12000062	12000062
6	Assembly, Shelf Cabinet Track, Left	640177	640177	640177	640177
7	123 Gum & Mint Filler Panel, for use with no Gum & Mint	12000121	12000121	12000121	12000121
10	Assembly, Shelf Cabinet Track, Right.	640177-1	640177-1	640177-1	640177-1
11	Cabinet Receptacle Mounting Bracket Only	202177	202177	12000173	12000173
12	Drive Pin	440142-2	440142-2	N/A	N/A
13	Cabinet Back Harness, Assembly Complete 5,6, & 7 Shelf with Expander Plug,Kit #	17500015	16600085	16600127	16600127
	Cabinet Back Harness, Assembly Complete 6 & 7 Shelf.	660442-1	N/A	N/A	N/A
	Cabinet Back Harness, Assembly Complete 5 Shelf.	660442	N/A	N/A	N/A
14	Nut Hex Head (6-32)	404-6	404-6	404-6	404-6
15	Line Filter	380303	380303	380303	380303
16	Assembly Complete, Light Ballast & Filter, 117 Volt.	16600092	16600092	16600092	16600092
	Assembly Complete, Light Ballast & Filter, 230 Volt.	16600092-03	16600092-03	16600092-03	16600092-03
17	Screw, Pan Head, (6-32 X 3/8)	276-6R6	276-6R6	276-6R6	276-6R6
18	Ballast only, 117 Volt.	680514	680514	680514	680514
	Ballast only, 230 Volt.	680513-2	680513-2	680513-2	680513-2
19	Power Inlet Cord Only, Domestic.	16800052	16800052	16800052	16800052
	Power Inlet Cord with Plate, Domestic.	16600098	16600098	16600098	16600098
	See Page 5.16 for a complete list of Power Cords				
20	Strain Relief Bushing.	380052-3	380052-3	380052-3	380052-3
21	Pop Rivet	420078-1	420078-1	420078-1	420078-1
22	Cord Plate, Power Inlet.	202270	202270	202070	202070
22A	Expander Mounting Plate.	14400016	14400016	14400016	14400016

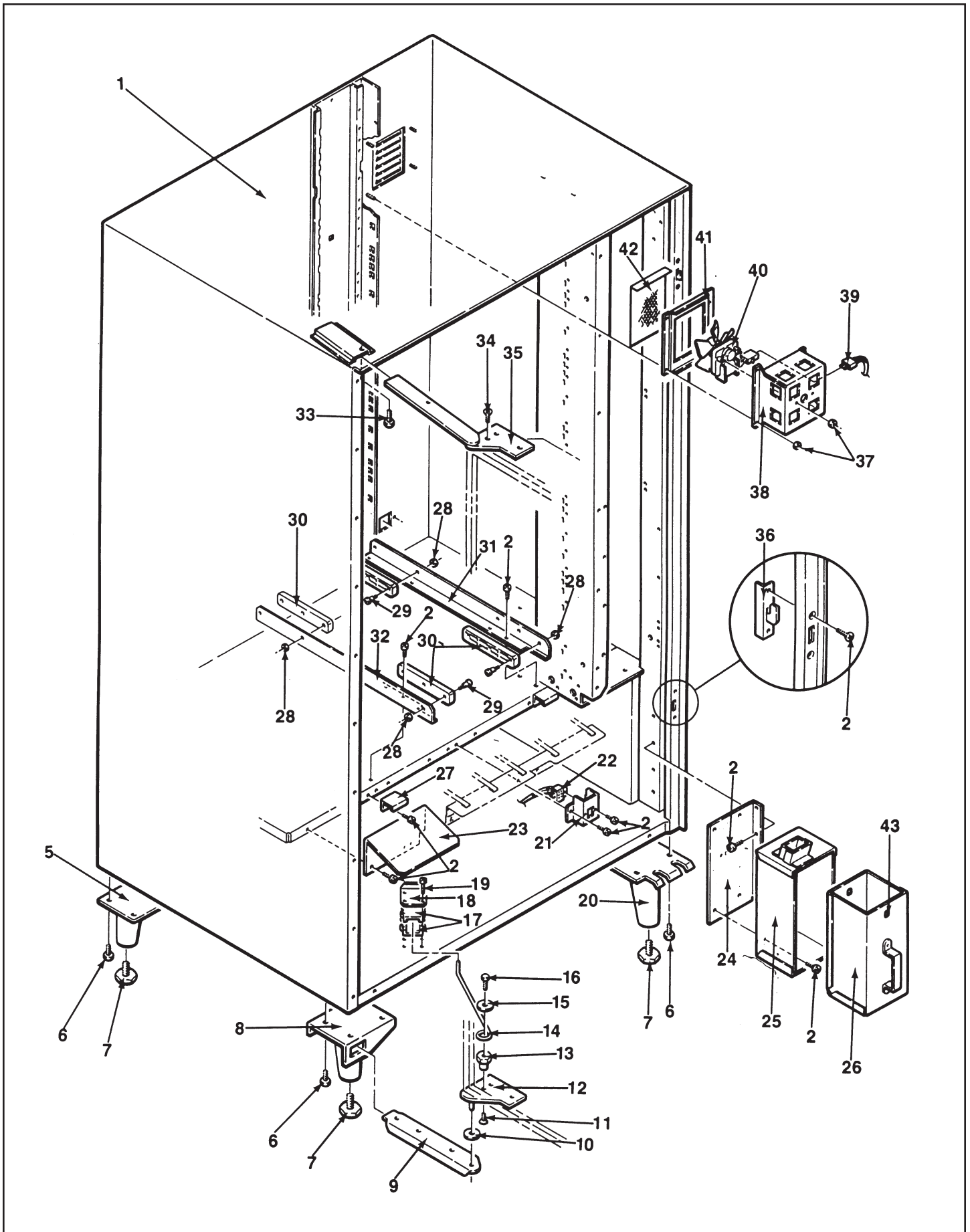

Key	Description	123 Below Serial # 12399090000	123A Between Serial #'s 123A99090000 123A01042200	123B Above Serial # 123B01043000	123C Above Serial# 123C02xxxxxx
1	Cabinet Assembly Complete, with Legs. Specify Color. (123)	750100-5	750101-10	750101-10	17500025-02
	Chilled Machine Cabinet Assembly Complete, with Legs. Specify Color. (123)	N/A	750101-13	750101-13	17500025-07
	Cabinet Assembly Complete, with Legs. Specify Color. (124)	N/A	750101-16	N/A	N/A
2	Screw, Pan Head, (8-32 X 3/8)	276-8R6	276-8R6	276-8R6	276-8R6
5	Leg Assembly Rear, Specify Color.	600195	600195	600195	600195
6	Screw, Hex Head, (5/16 – 18 X _)	420187	420187	420187	420187
7	Leg Leveler.	300103	300103	300103	300103
	Leg Leveler Bolt "Multisnack".	660599	660599	660599	660599
8	Front Leg Assembly, Pivot Side, Specify Color.	600302	600302	600302	600302
9	Lower Hinge Support, Specify Color.	202088	202088	202088	202088
10	Washer (1-1/4).	420010-18	420010-18	420010-18	420010-18
11	Screw, Flat Head (1/4 – 20 X _)	420003	420003	420003	420003
12	Lower Door Plate Assembly	640154	640154	640154	640154
13	Door Stop Anchor	300156	300156	300156	300156
14	Door Stop Rod	400095	400095	400095	400095
15	Washer	420010-10	420010-10	420010-10	420010-10
16	Screw, Hex Head Machine, (1/4–20 X _)	114-41-8	114-4-8	114-4-8	114-4-8
17	Friction Pad	420204	420204	420204	420204
18	Door Stop Plate	201042	201042	201042	201042
19	Screw, Pan Head, Self Tap, (10-32 X 1)	277-10R16	277-10R16	277-10R16	277-10R16
20	Front Leg Assembly, Lock Side.	600197	600197	600197	600197
23	Plate, Gum & Mint Deflector.	12000038	12000038	12000038	12000038
24	Cash Box Support.	202809	202809	202809	202809
25	Assembly, Cash Box Mounting.	600813	600813	600813	600813
26	Cash Box.	600179-1	600179-1	600179-1	600179-1
27	Gum & Mint Tray Catch	201453	12000006	12000006	12000006
28	Nut (1/4 - 28)	437- 41	437- 41	437- 41	437- 41
29	Screw, Shelf Roller.	300137	300137	300137	300137
30	Gum & Mint Tray Slide.	440278	440278	440278	440278
31	Assembly Complete, Gum & Mint Support, Right.	660439	16600039	16600039	16600039
31a	Rail, Gum & Mint Support, Right.	202064	12000061	12000061	12000061
32	Assembly Complete, Gum & Mint Support, Left.	660439-1	16600039-01	16600039-01	16600039-01
32a	Rail, Gum & Mint Support, Left.	202064-1	12000061-01	12000061-01	12000061-01
33	Screw, Hex Head, (5/16 – 18 X 3/8).	164-51-7	164-51-7	164-51-7	164-51-7
33a	Nut, Keps, (1/4 – 20).	N/A	N/A	N/A	N/A
34	Screw, Flat Head, (1/4-20 X _).	420003-01	420003-01	420003-01	420003-01
35	Upper Hinge Assembly.	640107-1	640107-1	640107-1	640107-1
36	Door Catch Assembly.	12000290	12000290	12000290	12000290
37	Hex Nut (8-32).	404-4	404-4	404-4	404-4
38	Kit, Fan add on 117 Volt. Includes items 37-43.	750102-4	750102-4	750102-4	750102-4
	Kit, Fan add on 240 Volt. Includes items 37-43.	750102-5	750102-5	750102-5	750102-5
	Fan Housing only.	202072	202072	202072	202072
39	Harness, Fan.	680456	680456	680456	680456
40	Fan Motor Only, 117 Volt.	360122-2	360122-2	360122-2	360122-2
	Fan Motor Only, 230 Volt.	360122-3	360122-3	360122-3	360122-3
41	Screen Bracket.	202070	202070	202070	202070
42a	Screen.	202071	202071	202071	202071
42b	Louver.	640178	640178	640178	640178
42c	Cover Plate (used with no fan), Not Shown.	16400024	16400024	16400024	16400024
43	Lock and Cam w/2 Keys, Cash Box.	750097	750097	750097	750097

120 / swing panel

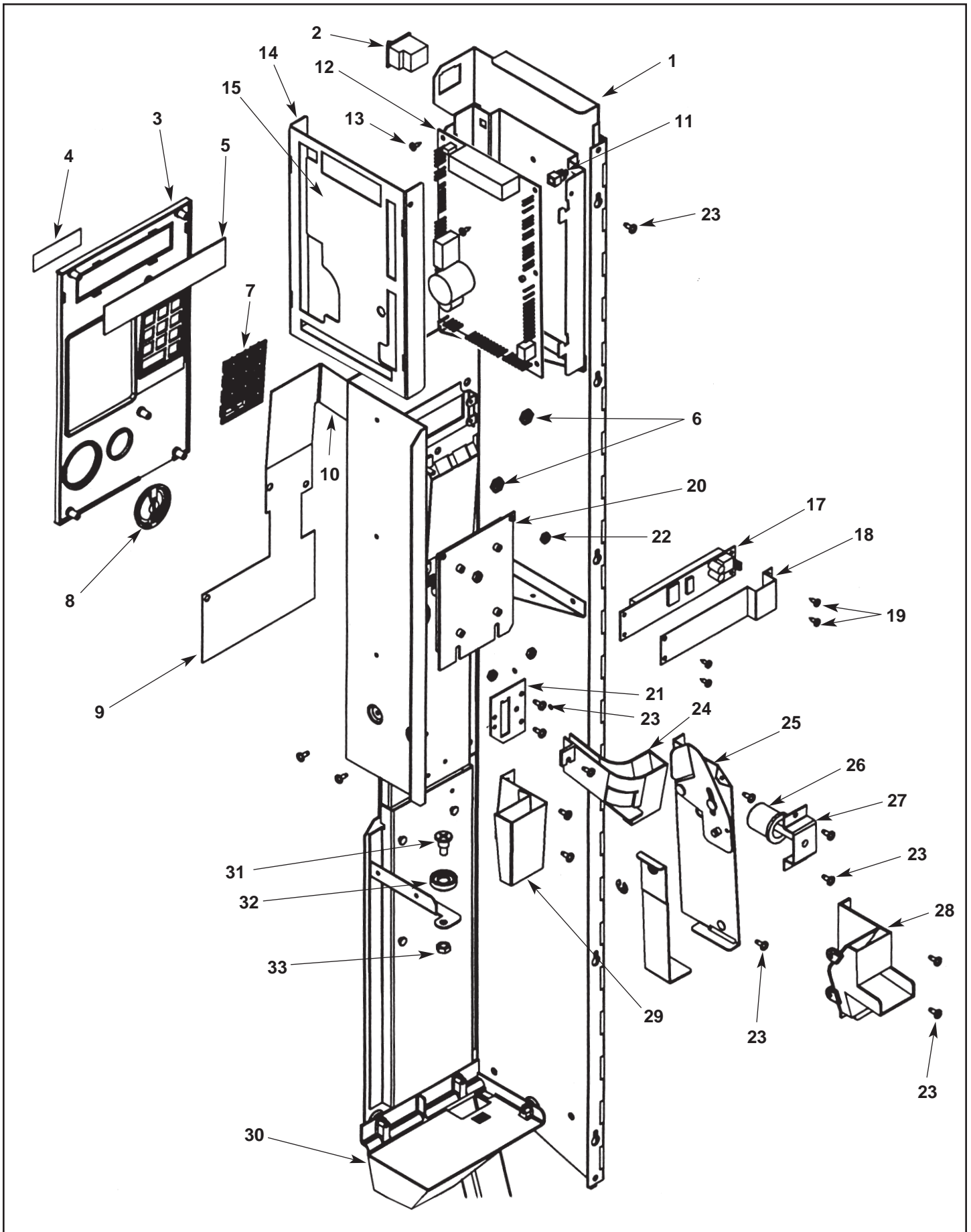

Key	Description	123	123A	123B	123C
1	Swing Panel Assembly Complete W/O Logic Board. (Black)	660681	660681	660681	16600244
	Swing Panel Assembly Complete W/O Logic Board. (Euro Gray)	660681-1	660681-1	660681-1	16600244-01
	Swing Panel Assembly Complete W/O Logic Board. (Odyssey)	660681-2	660681-2	660681-2	16600244-02
	Swing Panel Weldment, Specify Color.	600812	600812	600812	16000146
2	Door Switch and Harness Assembly.	660266	660266	660266	660266
3	Selector Bezel – Black	440442	440442	440442	440442
	Selector Bezel – Lt Gray	440442-1	440442-1	440442-1	440442-1
	Selector Bezel - Dk Gray. (Odyssey)	440442-2	440442-2	440442-2	440442-2
4	Api Logo – Lt Gray.	17400102-01	17400102-01	17400102-01	17400102-01
	Api Logo – Dk Gray.	17400102	17400102	17400102	17400102
5	Display Lens.	440310	440310	440310	440310
6	Pal Nut 1/4" Self Threading.	18443	18443	18443	18443
7	Selection Buttons Braille – Dark Gray.	14400015	14400015	14400015	14400015
	Selection Buttons Braille – Lt Gray.	14400015-01	14400015-01	14400015-01	14400015-01
8	Coin Insert – Dark Gray (USA, El Salvador, Ethiopia, Tahiti).	440445	440445	440445	440445
	Coin Insert – Dark Gray (Chile, Brazil, France, Germany, Taiwan).	440445-1	440445-1	440445-1	440445-1
	Coin Insert – Dark Gray (UK, Turkey, Panama, Columbia, China, Peru, Sweden, South Africa, Saudi Arabia).	440445-2	440445-2	440445-2	440445-2
	Coin Insert – Dark Gray (Belgium, Spain, Argentina, Canada).	440445-3	440445-3	440445-3	440445-3
	Coin Insert – Dark Gray (Australia, New Zealand, Italy, Lebanon, Mexico, Holland, Israel, Malaysia, Tunisia, Singapore, Oman, Uruguay, Denmark, Philippines, United Arab Emirate).	440445-4	440445-4	440445-4	440445-4
	Coin Insert – LT Gray (USA, El Salvador, Ethiopia, Tahiti).	440445	440445	440445	440445
	Coin Insert – LT Gray (Chile, Brazil, France, Germany, Taiwan).	440445-1	440445-1	440445-1	440445-1
	Coin Insert – LT Gray (UK, Turkey, Panama, Columbia, China, Peru, Sweden, South Africa, Saudi Arabia).	440445-2	440445-2	440445-2	440445-2
	Coin Insert – LT Gray (Belgium, Spain, Argentina, Canada).	440445-3	440445-3	440445-3	440445-3
	Coin Insert – LT Gray (Australia, New Zealand, Italy, Lebanon, Mexico, Holland, Israel, Malaysia, Tunisia, Singapore, Oman, Uruguay, Denmark, Philippines, United Arab Emirate).	440445-4	440445-4	440445-4	440445-4
9	Selector Switch (MasterMenu Keypad).	360253	360253	360253	360253
	Braille Overlay, Selection Switch (Not Shown)	17400008	17400008	17400008	17400008
10	Selection Switch Extension Cable.	680633	680633	680633	680633
11	Board Standoff.	420096	420096	420096	420096
12	Logic Board, See Page 5.15	360274	360274	360274	360274
13	Board Mounting Screw, 8 X 3/8 Plastite.	305-8R6	305-8R6	305-8R6	305-8R6
14	Board Cover W/O Decal.	202802	202802	202802	202802
15	Decal, Board Cover.	460734	460734	460734	460734
17	Display Board.	360244	360244	360244	360244
18	Insulator, Display Board.	360256	360256	360256	360256
19	Screw, Display Board Mounting.	200-6R6	200-6R6	200-6R6	200-6R6
20	Validator Blocking Plate, Black.	660580	660580	660580	660580
	Validator Blocking Plate, Lt Gray.	660580-1	660580-1	660580-1	660580-1
	Validator Blocking Plate, Dk Gray. (Odyssey)	660580-2	660580-2	660580-2	660580-2
21	Coin Chute Bracket.	201712	201712	201712	201712
22	8-32 Hex Nut.	404-8	404-8	404-8	404-8
23	Screw, 8-32 X 3/8	276-8R6	276-8R6	276-8R6	276-8R6
24	Coin Chute.	440311	440311	440311	440311
25	Coin Return Assembly.	660682	660682	660682	660682
26	Coin Return Button – Dark Gray	440289	440289	440289	440289
	Coin Return Button – Milled, Card Only.	440289-1	440289-1	440289-1	440289-1
	Coin Return Button – Black.	440281-2	440281-2	440281-2	440281-2
27	Coin Return Bracket.	201660	201660	201660	201660
28	Coin Chute Assembly, Water Diverter.	660488	660488	660488	660488
29	Coin Chute.	14400008	14400008	14400008	14400008
30	Assembly Complete, Coin Chute. (2 pieces)	750182	750182	750182	750182
31	Odyssey Coin Chute Assembly. (2 pieces)	16600069	16600069	16600069	16600069
32	Hole Snap Bushing.	420040-3	420040-3	420040-3	420040-3
33	Nut, 1/4-28 Keps.	437-41	437-41	437-41	437-41
34	Harness Mounting Bracket (Micromech) . Not Shown.	202024	202024	202024	202024

120 / power supply box

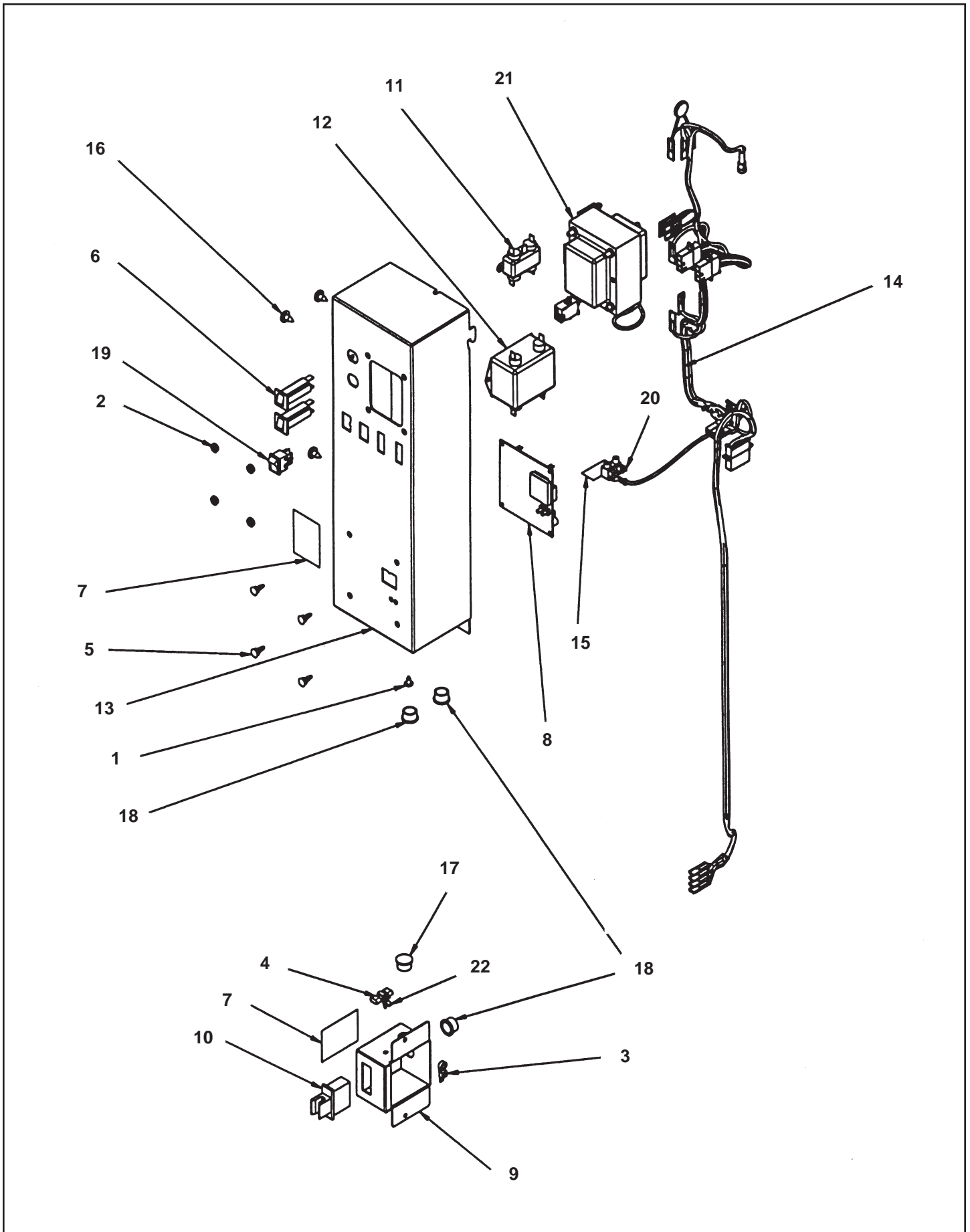

Item No.	Part No.	Description
	16600073	Junction Box Complete 117V Ambient, Domestic. (When using in machines sel # 12399094999 or below alsoorder part # 12000103).
	16600053	Junction Box Complete 117V, Chilled, Domestic
	16600053-01	Dual Zone Junction Box Complete 117V.
	16600057	Junction Box Complete 117V Chilled Export
	16600074	Junction Box Complete 117V Ambient, Export.
	16600075	Junction Box Complete 230V Ambient, Export.
	16600054	Junction Box Complete 230V, Chilled, Export
	16600054-01	Dual Zone Junction Box Complete 230V
	210-8R6	# 8 X 3/8 Screw
2	438-8	8-32 Nut
3	380078	Cable Tie
4	380263	Interlock Cheat Tool
5	17100002	Circuit Board Standoff
6	380241	Circuit Breaker 3 Amp
7	460642	Decal, Voltage
8	13600001	Chilled Digital Temp Control Assembly, Includes Board and Probe.
	13600005	Dual Zone Temp Control Assembly, Includes Board and Probe's.
	13600001-01	Chilled Temp Control, Board Only.
	13600005-01	Dual Zone Temp Control, Board Only.
	13600001-02	Probe Only, Dual Zone (2 each) & Chilled (1 each).
9	12000122	Door Switch Box
10	380262	Door Switch
11	380303	RFI Filter
12	380304	RFI Filter
13	12000099	Weldment, Junction Box
14	16800031	Junction Box Harness, 117V, Ambient
	16800022	Junction Box Harness 117V, Chilled & Dual Zone
	16800015	Junction Box Harness 230V, Chilled & Dual Zone
	16800030	Junction Box Harness, 230V, Ambient, Export.
	16800030-01	Junction Box Harness, 117V, Ambient, Export.
15	440065	Mylar Insulation
16	216-41R8	Screw 1/4 X 2
17	420040-1	Snap Bushing / Hole Plug
18	420040-2	Snap Bushing / Hole Plug
19	380243	Rocker Switch
20	380285	Terminal Block
21	13900003	Transformer, 117V
	13900004	Transformer, 230V
22	380321	Clip for Interlock Switch Tool
23	12000103	Power Box Mounting Panel (not shown).

Item No.	Part No.	Description

logic board

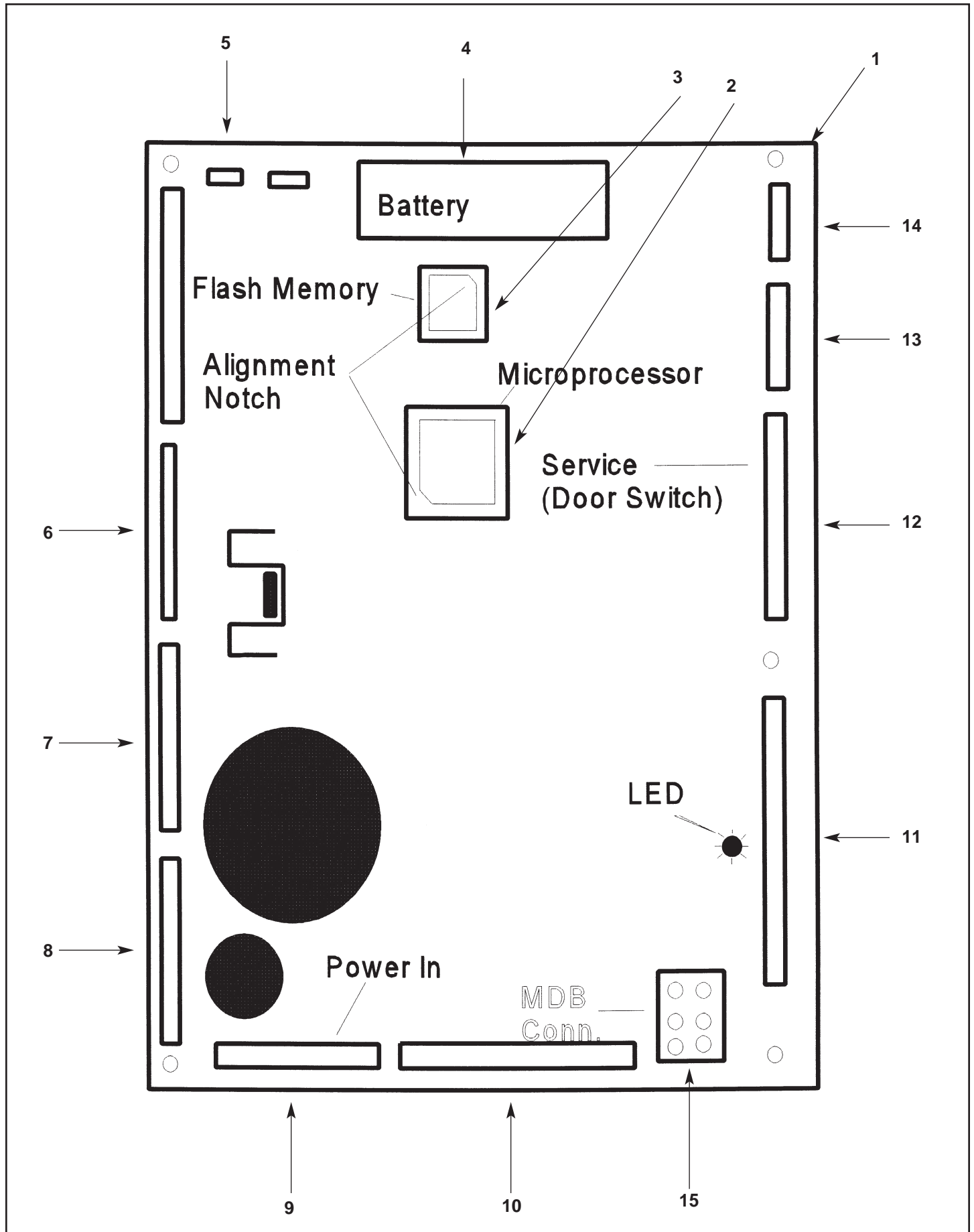

snack shelf

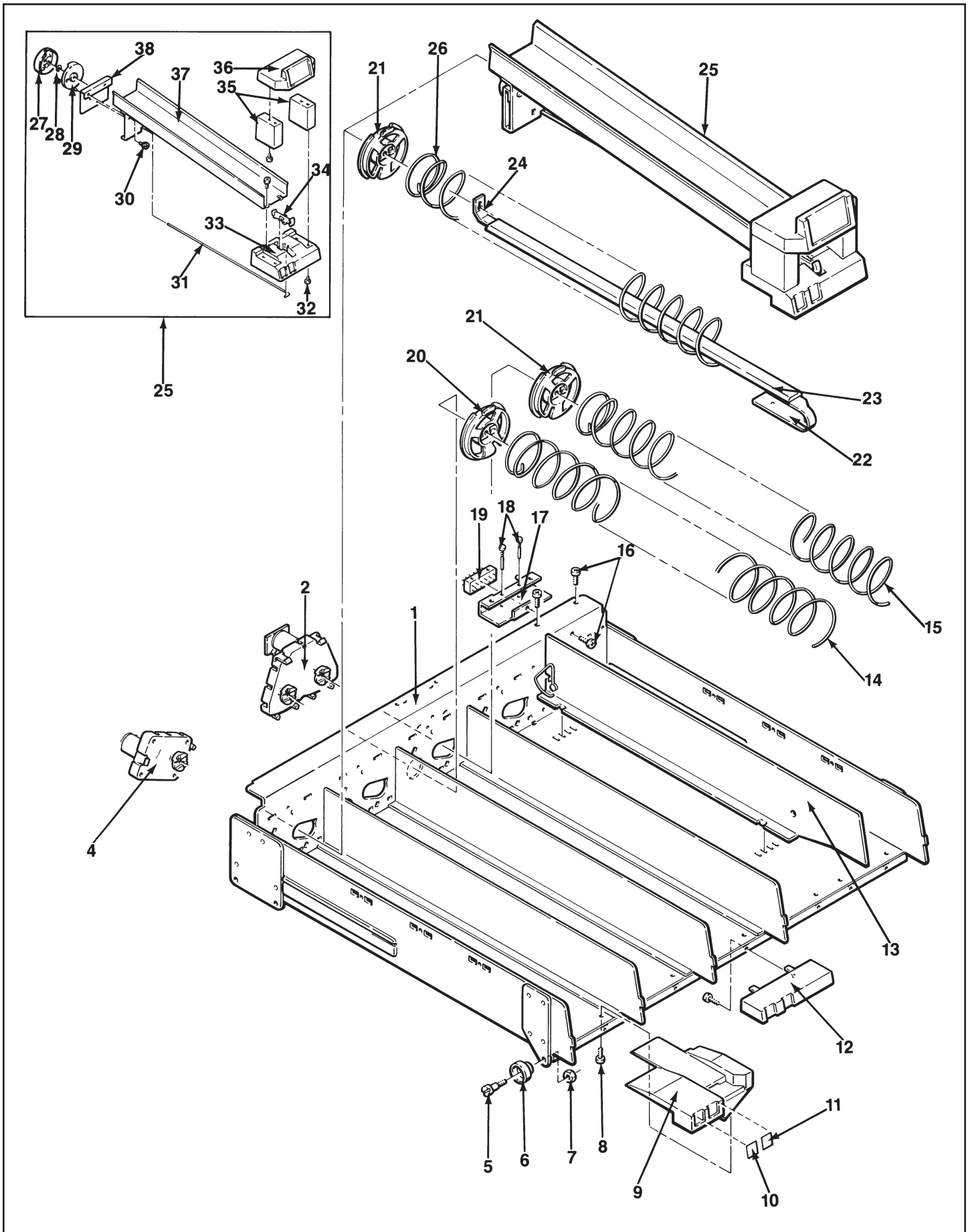

Key	Description	123 & 123A	123B & 123C
1	Snack Shelf w/o Spirals, Complete, including motors and harness	750121-10	750121-15
	Dual Snack Shelf w/o Spirals, Complete, including motors and harness	750162-9	750162-13
	Snack Shelf Only (Weldment)	600761	600761
2	Dual Spiral Motor Only, White/Blue	360240	360240
	Kit, Dual Spiral Add on	750159-2	750159-2
4	Vend Motor Complete, White/Blue	360275	360275
5	Screw, Shelf Roller	300203	300203
6	Roller, Shelf	440362	440362
7	Nut, Keps (1/4 x 28)	437-41	437-41
8	Screw, Pan Head, Phillips, Plastite (8-16 x 3/8)	305-8R6	305-8R6
9	Price and Selection Tab Holder (Single Spiral)	440285	440285
10	Item Tabs	460669	460669
11	Price Tabs. See Chart on Page 5.22		
12	Dual Spiral Pastry Shelf Front	440367	440367
13	Spacer, Snack Shelf	640101	640101
	Snack Shelf Extender (Not Shown)	202770	202770
14	Left Hand Dual Spirals, See Chart at bottom of page		
15	Right Hand Dual Spirals, See Chart at bottom of page		
16	Screw, Pan Head. Self Tap (8-32 x 3/8)	276-8R6	276-8R6
17	Bracket Only	600601	16000083
18	Pin, Shelf Plug	420142-2	420046-4
19	Assembly Complete, Harness Plug and Bracket	660435-2	660435-7
	Harness only, no Bracket	680448	16800049
20	Spiral Retainer, Left Hand. Gray	440406	440406
21	Spiral Retainer, Right Hand. White	440405	440405
22	Front Rail Support Only	201534	201534
23	Product Rail Assembly, for use with Single Pastry Spiral	660330-2	660330-2
24	Rear Bracket Only	200913	200913
25	Kit, Can Dispenser	750083	750083
26	Single Snack Spirals, See Chart at bottom of page		
27	Drive Cam Rear	440201	440201
28	Retaining Ring #31	751-31	751-31
29	Drive Cam, Front	440200	440200
30	Shoulder Bushing	300184	300184
	Screw Type # 23	277-10R8	277-10R8
31	Actuator Wire	400094-1	400094
32	Screw, Plastite (8-16 x 3/8)	305-8R6	305-8R6
33	Price & Selection Trim	440196	440196
34	Stop Leveler	440199	440199
35	Leg, Top Can Guide & Sign Trim	440198	440198
36	Top Can Guide & Sign Trim	440197	440197
37	Can Dispenser, Trough Only	600308-1	600308
38	Cam, Mounting Bracket & Spring Assembly	640109	640109

	Single Snack Spirals		Left Hand Dual Spirals		Right Hand Dual Spirals	
	121	122-123	121	122-123	121	122-123
3 Space	N/A	N/A	400184-1	N/A	400185-1	N/A
4 Space	400165-1	14000002-01	400186-1	N/A	400183-1	N/A
6 Space	400124-1	400162-1	400174-1	14000003-01	400173-1	400167-1
7 Space	N/A	400153-1	N/A	400178-1	N/A	400164-1
8 Space	400125-1	N/A	400175-1	N/A	400116-1	N/A
9 Space	N/A	N/A	N/A	400179-1	N/A	400166-1
10 Space	400126-1	400127-1	400176-1	400169-1	400117-1	400168-1
12 Space	N/A	400128-1	N/A	400170-1	N/A	400120-1
15 Space	N/A	400129-1	N/A	400171-1	N/A	400121-1
30 Space	N/A	400136-1	N/A	N/A	N/A	N/A
40 Space	N/A	400137-1	N/A	N/A	N/A	N/A

candy shelf

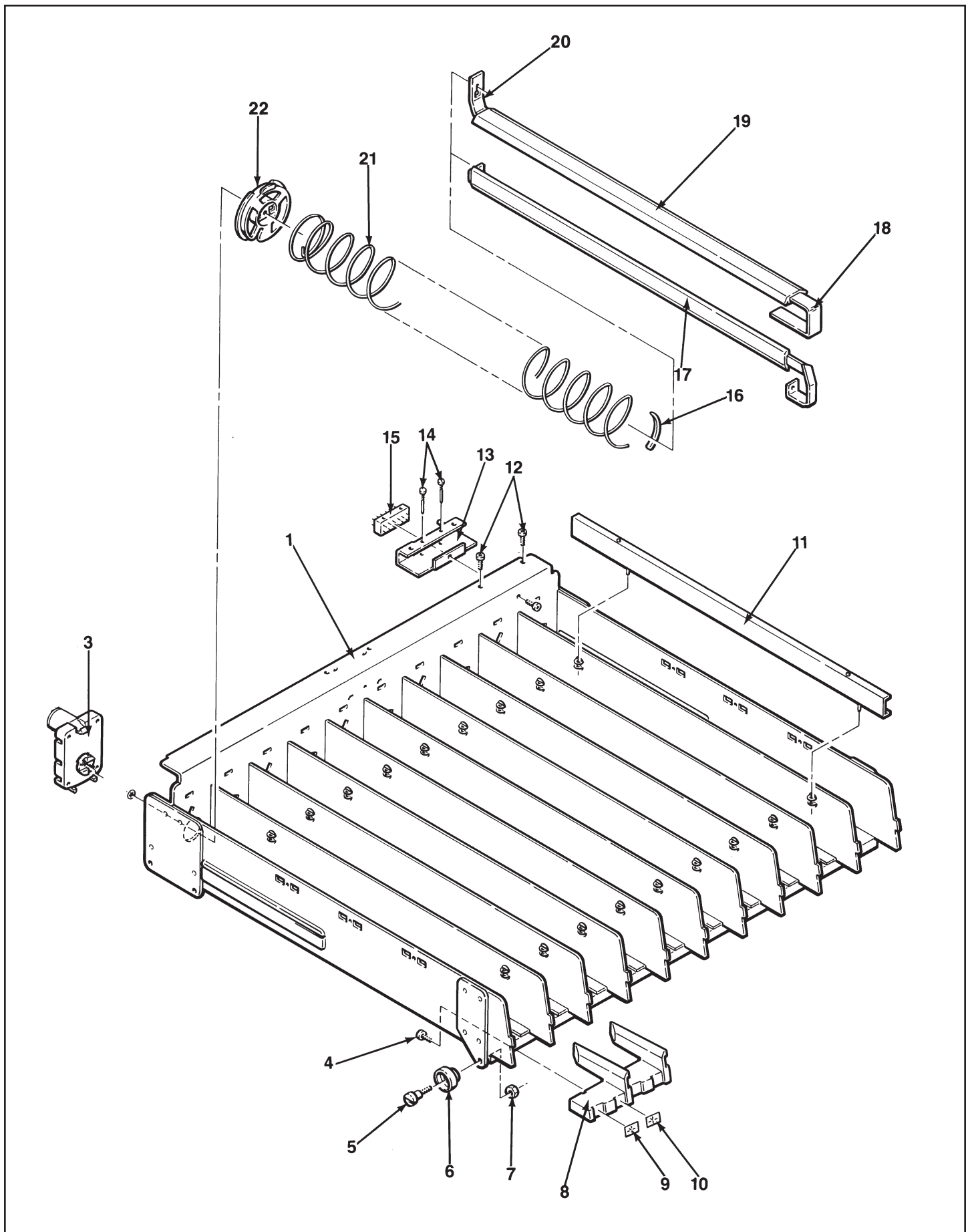

Key	Description	123 & 123A	123B & C
1	Candy Shelf Complete with Fixed Dividers, w/o Spirals	750122-10	750122-16
	Fixed Candy Shelf Only. Weld Assembly	600762	600762
3	Vend Motor Complete, White/Blue	360275	360275
	Vend Motor Half Cycle, Brown/White	360241	360241
	Kit, 2 Selection Add-On	750150-4	750150-4
	Kit, Dual Spiral Add on w/o Spirals. (one per selection)	750159-2	750159-2
	Kit, Half Cycle Add-On	750135-2	750135-2
4	Screw, Plastite (8-16 x 3/8)	305-8R6	305-8R6
5	Screw, Shelf Roller	300203	300203
6	Shelf Roller	440362	440362
7	Nut (1/4 - 28)	437-41	437-41
8	Price & Selection Tab Holder, Candy	440262	440262
9	Item Tabs	460669	460669
10	Price Tabs See Chart on Page 5.22		
11	Assembly, Candy Spacer	660178	660178
	Assembly, Candy Spacer. For use with Half Cycle Motor	600178-4	600178-4
12	Screw, Pan Head (8-32 x 3/8)	276-8R6	276-8R612
13	Bracket Only	600601	16000083
14	Shelf Plug Pin	420142-2	N/A
15	Harness, Candy Shelf with Bracket	660435-1	660435-8
	Harness Only	680445-1	16800050
16	Product Pusher	440141-1	440141-1
17	Product Guide Assembly. For use with Half Cycle Motor Domestic	660503	660503
	Half Cycle Rail Export	600669	600669
	Small Product Guide for use with Thin Mints	660296	6602961
	Product rail for use with Kit Kat	660191-8	660191-8
18	Front Support Bracket Only	201258	201258
19	Product Rail Assembly, For use with a Candy Spiral. Includes 18, 18a, & 18b	660191	660191
	Plastic Rail Only	440148-1	440148-1
	Product Rail for use with 12 oz. Cans	600618	600618
20	Rear Support Bracket Only	200913	200913
21	Candy Spirals, See Chart at Bottom of Page		
22	Spiral Lock, White	440405	440405

Candy Spirals	122/123
5 Space	14000004-01
6 Space	400174-1
7 Space	400164-1
9 Space	400166-1
10 Space	400168-1
12 Space	400120-1
15 Space	400121-1
18 Space	400122-1
24 Space	400123-1
30 Space	400135-1
40 Space	400138-1

convertible shelf

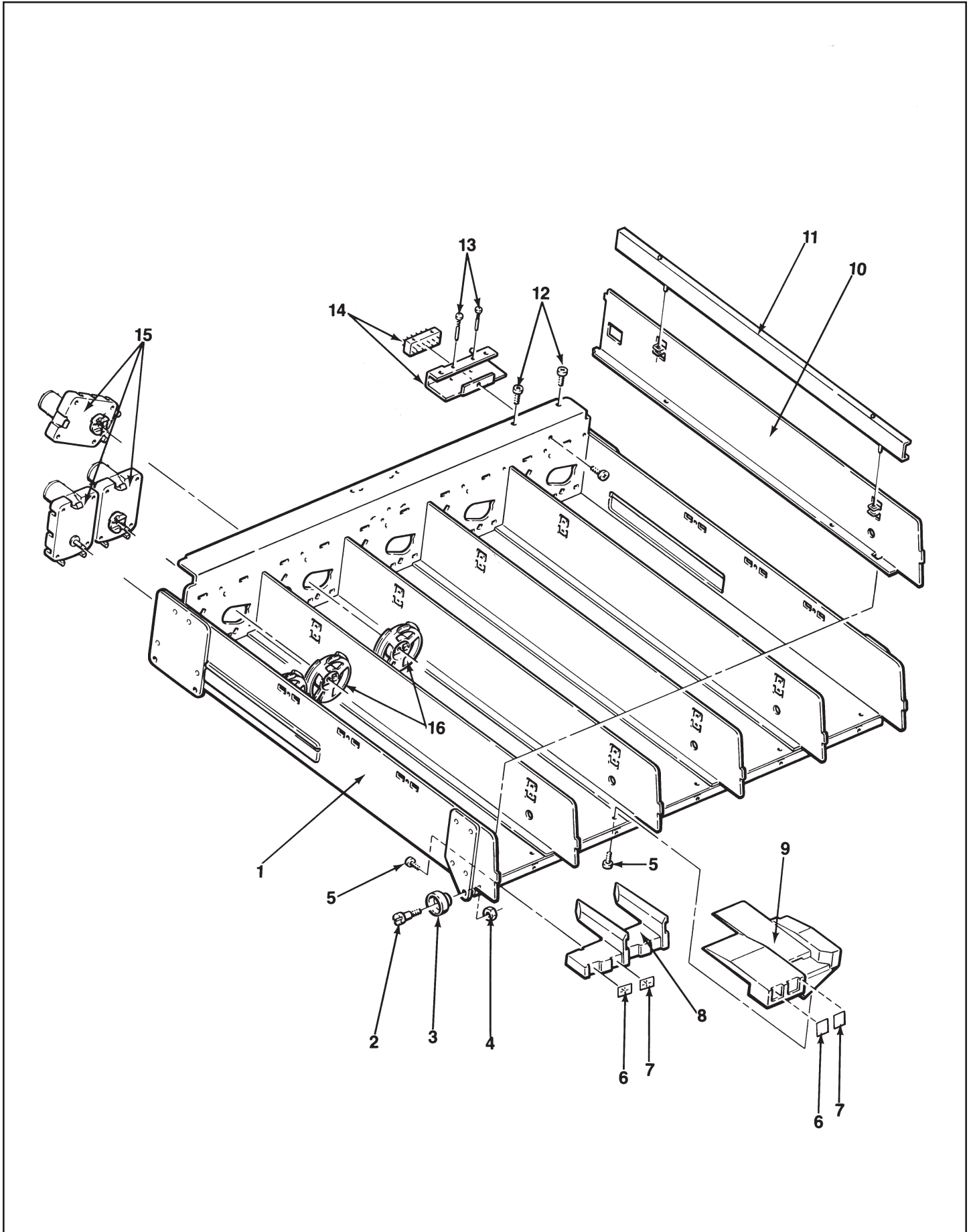

Key	Description	123 & 123A	123B & 123C
1	Convertible Candy Shelf Complete, w/o Spirals (All Candy Selections)	750147-18	16600125-02
	Convertible Pastry Shelf Complete, w/o Spirals (All Pastry/Snack Selections)	750159-2	16600125-01
	Convertible Shelf Only, Weld Assembly	600761	600761
2	Screw, Shelf Roller	300203	300203
3	Shelf Roller	440362	440362
4	Nut (1/4 - 28)	437-41	437-41
5	Screw, Plastite (8-16 x 3/8)	305-8R6	305-8R6
6	Item Tabs	460669	460669
7	Price Tabs, See Chart at Bottom of Page		
8	Price & Selection Tab Holder, Candy	440262	440262
9	Price and Selection Tab Holder, Snack	440285	440285
10	Shelf Divider, Candy	200753-2	200753-2
11	Assembly, Candy Spacer	660178	660178
12	Screw, Pan Head (8-32 x 3/8)	276-8R6	276-8R6
13	Pin, Shelf Plug	420142-2	N/A
14	Harness, Candy Shelf with Bracket	660435	660435-8
	Harness Only	680445	16800050
15	Vend Motor Complete, White/Blue	360275	360275
	Vend Motor Half Cycle, Brown/White	360241	360241
	Kit, 2 Selection Add-On	750150-4	750150-4
	Kit, Dual Spiral Add-On w/o Spirals (One per selection)	750159-2	750159-2
	Kit, Half Cycle Add-On	750135-2	750135-2
16	Spiral Lock, White	440405	440405

price tabs

460347	Price Tabs Ass't 25¢ - \$1.50
460740	Price Tabs Ass't &.75 - \$1.25
460602	Price Tabs Ass't \$3.10 - \$4.05
14600010	Price Tabs Ass't \$3.25 - \$5.50
460347-1	Price Tabs, All \$.30 - \$.35
460347-2	Price Tabs, All \$.40 - \$.45
460347-3	Price Tabs, All \$.50 - \$.55
460347-4	Price Tabs, All \$.60 - \$.65
460347-5	Price Tabs, All \$.70 - \$.75
460347-6	Price Tabs, All \$.80 - \$.85
460347-7	Price Tabs, All \$.90 - \$.95
460347-8	Price Tabs, All \$1.00 - \$1.05
460347-9	Price Tabs, All \$1.10 - \$1.15
460347-10	Price Tabs, All \$1.20 - \$1.25
460347-11	Price Tabs, All \$1.30 - \$1.35

460347-12	Price Tabs, All \$1.40 - \$1.45
460347-13	Price Tabs, All \$1.50 - \$1.55
460347-14	Price Tabs, All \$1.60 - \$1.65
460347-15	Price Tabs, All \$1.70 - \$1.75
460347-16	Price Tabs, All \$1.80 - \$1.85
460347-17	Price Tabs, All \$1.90 - \$1.95
460347-18	Price Tabs, All \$2.00 - \$2.05
460347-19	Price Tabs, All \$2.10 - \$2.15
460347-20	Price Tabs, All \$2.20 - \$2.25
460347-21	Price Tabs, All \$2.30 - \$2.35
460347-22	Price Tabs, All \$2.40 - \$2.45
460347-23	Price Tabs, All \$2.50 - \$2.55
460347-24	Price Tabs, All \$2.60 - \$2.65
460347-25	Price Tabs, All \$2.70 - \$2.75
460347-26	Price Tabs, All \$2.80 - \$2.85

460347-27	Price Tabs, All \$2.90 - \$2.95
460347-28	Price Tabs, All \$3.00 - \$3.05
460529	Price Tabs, French Ass't
460540	Price Tabs, Mexico, Ass't
14600013	Price Tabs, Mexico \$1.00 - \$7.50
460561	Price Tabs, Spanish .35 pts - 125 pts
17400135	15 pents - 1.20pounds
460727	Price Tabs, Italian 100 - 600
14600022	Price Tabs, Italian 300 - 2000
14600023	Price Tabs, Italian 500 - 3000
460777	Price Tabs, Myl rm 60 - rm 2.00
460775	Price Tabs, Aus \$1.20 - \$1.60
460776	Price Tabs, Aus \$1.70 - \$2.50
17400119	Price Tab Euro \$.10 - \$3.60

gum & mint shelf

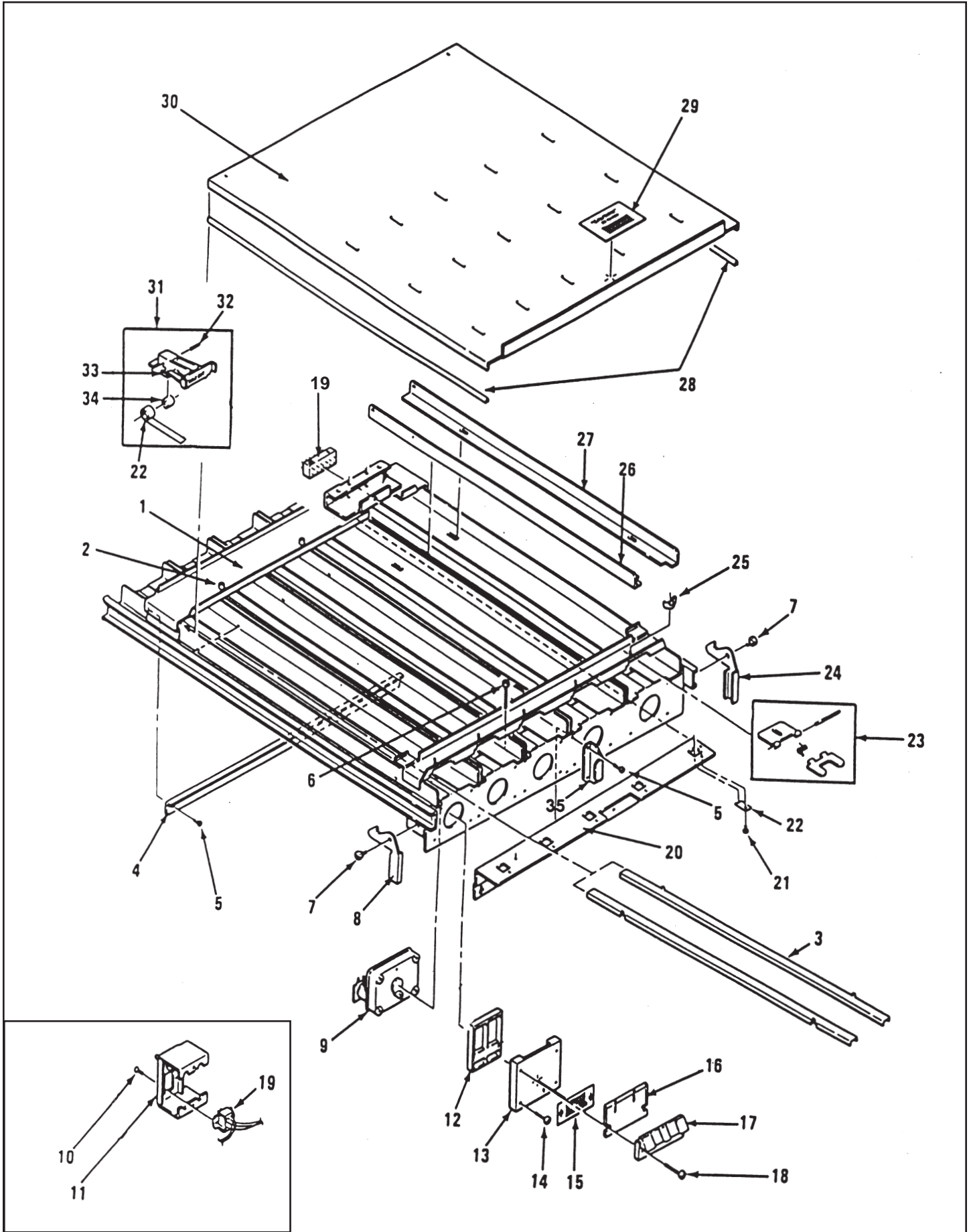

Key	Description	123 Below Serial # 12399090000	123A Between Serial #'s 123A99090000 123A01xxxxxx	123B & 123C Above Serial # 123B99090000
1	Assembly Complete, G & M Domestic	660316	16600019	16600198
	Add on Kit, G & M Domestic	750165	750165-18	750165-36
	Shelf Only, G & M Domestic	600420	16000004	16000004
	Assembly Complete, G & M Export	660317-6	16600018	16600200
	Add on Kit, G & M Export	501592	750165-16	750165-38
	Shelf Only, G & M Export	600463-3	16000007	16000007
	Assembly Complete, G & M Australia	660317-12	16600017	16600199
	Add on Kit, G & M Australia	750165-10	750165-17	750165-37
	Shelf Only, G & M Australia	600463-3	16000007	16000007
2	Snap Bushing	420040-9	420040-9	420040-9
3	Thin Mint Adapter	201412	201412	201412
4	G & M Rear Pusher Stop, Domestic	201458-1	201458-1	201458-1
	G & M Rear Pusher Stop, Export	201458-3	201458-3	201458-3
5	Screw (8-32 x 3/8), Pan Head, Self Tap	276-8R6	276-8R6	276-8R6
6	Screw (1 3/8), Pan Head, Phillips	217-8R22	217-8R22	217-8R22
7	Shoulder Bushing	300184	300184	300184
8	G & M Shelf Latch, Left Side	12000032-01	12000032-01	12000032-01
9	G & M Motor, White	360105	360105	360105
10	Screw (6-32 x 1/2) Flat Head	400089	Not Used	Not Used
11	G & M Mounting Bracket	600427	Not Used	Not Used
12	G & M Ejector	440267	440267	440267
13	G & M Front Shelf Base	440266	440266	440266
14	Screw (#8 x 1") Pan Head	218-8R16	218-8R16	218-8R16
15	Decal, G & M Shelf Latch	460352	460352	460352
16	Display Stop, Column Front	440270	440270	440270
17	G & M Shelf Front	440273	440273	440273
18	Screw (#8 x 1 3/8) Pan Head	218-8R22	218-8R22	218-8R22
19	Harness with Bracket, Domestic	660341	16600064	16600179
	Harness W Bracket, Export & Australia	660341	16600067	16600182
	Harness only, no Bracket, Domestic	680306	16800002	16800077
	Harness only, no Bracket, Export & Aus	680328	16800005	16800080
20	Strap, G & M Pusher Stop, Domestic	201414-1	12000002-02	12000002-02
	Strap, G & M Pusher Stop, Export & Aus	201553	12000002	12000002
21	Screw (6-32 x 5/16) Flat Head	262-6R5	262-6R5	262-6R5
22	Spring, G & M Pusher Return	400106	400106	400106
23	G & M Display Hinge Assy. Domestic & Export except Australia	660314	660314	660314
	G & M Display Hinge Assy, Australia Only	660314-1	660314-1	660314-1
24	G & M Shelf Latch, Right Side	12000032	12000032	12000032
25	Wing Nut (8 x 32)	420023	420023	420023
26	Column Spacer, Left	201411-1	201411-1	201411-1
27	Column Spacer, Right	201411	201411	201411
28	Shelf Grommet (NGS #122)	420296	420296	420296
29	Caution Decal, G & M Shelf	460351	460351	460351
30	Cover, G & M Shelf, Domestic	201409-2	201409-2	201409-2
	Cover, G & M Shelf, Export & Aus	201530-2	201530-2	201530-2
31	Assembly Complete, Pusher & Spring	660313	660313	660313
32	Roll Pin	801C125-12	801C125-12	801C125-12
33	Pusher Only	440265	440265	440265
34	Roller, G & M Pusher	440274	440274	440274
35	Shelf Closer	201691	201691	201691

delivery bin

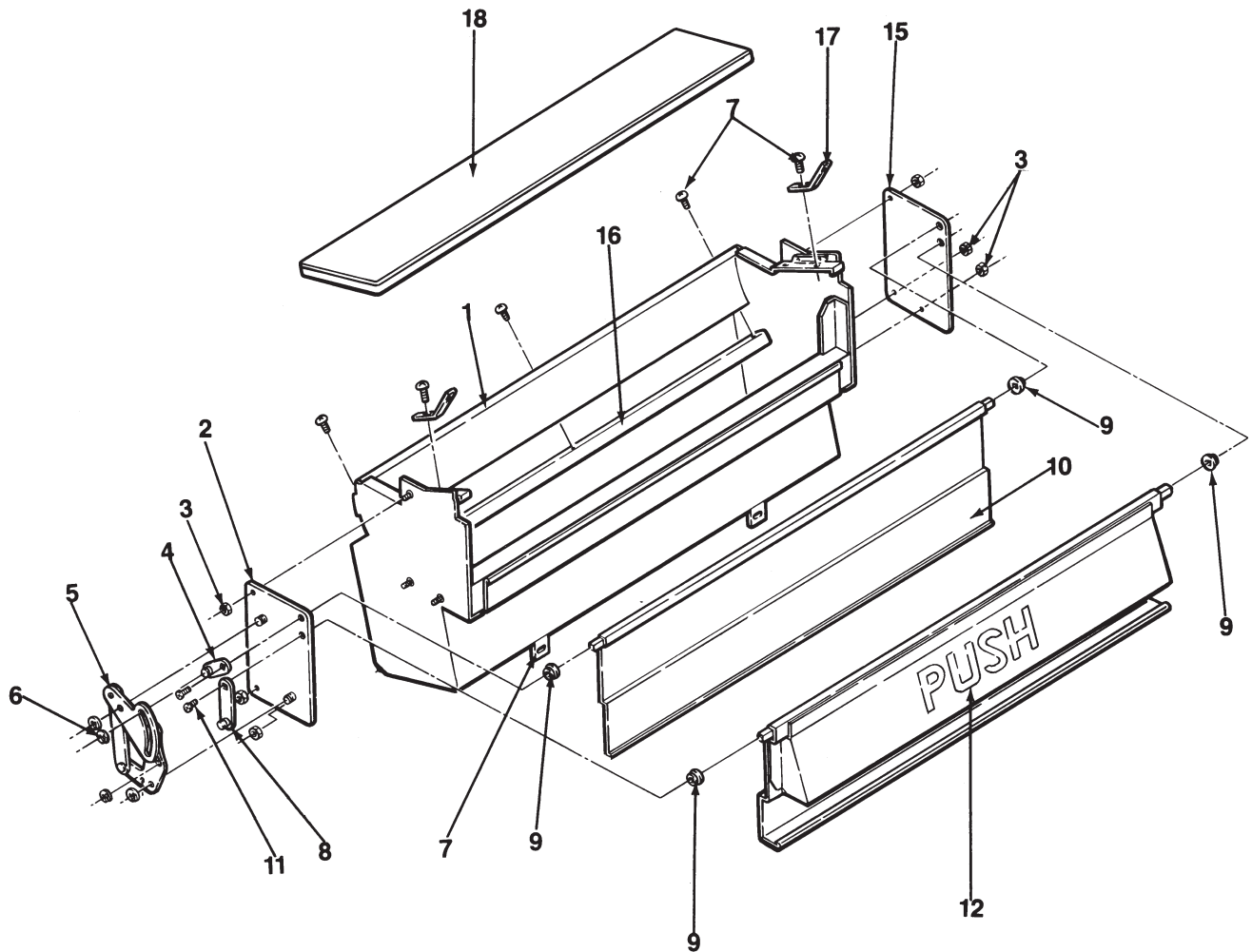

Key	Description	123	123A	123B	123C
1	Delivery Bin Assembly, Complete. Black	660558-5	660558-5	660558-5	16600268-02
	Delivery Bin Assembly, Complete. Gray	660558-7	660558-7	660558-7	16600268-03
	Delivery Bin Assembly, Complete. Odyssey	660558-20	660558-20	660558-20	16600268-09
	Delivery Bin Only.	600817	600817	600817	16000167-01
2A	Bin End Assembly Complete	16600293	16600293	16600293	16600293
2B	Arm Mounting Bracket.	640230	640230	640230	640230
3	8-32 Nut.	438-8	438-8	438-8	438-8
4	Inner Bin Arm.	640098	640098	640098	640098
5	Bin Door Drive Assembly.	640100-1	640100-1	640100-1	640100-1
6	Retaining Ring # 37	751-37	751-37	751-37	751-37
7	Kit, Lower Bracket Repair.	750183	750183	750183	750183
8	Door Drive Arm.	640097	640097	640097	640097
9	Door Bearing.	440129	440129	440129	440129
	Bin Door Washer (Not Shown).	420282	420282	420282	420282
10	Inner Door.	200763	200763	200763	200763
	Inner Door Steel.	200763-3	200763-3	200763-3	200763-3
11	Screw, (8-32 X 3/8)	276-8R6	276-8R6	276-8R6	276-8R6
12	Door, Delivery Bin Black.	440373	440373	440373	440373
	Door, Delivery Bin Gray.	440373-2	440373-2	440373-2	440373-2
	Door, Delivery Bin Odyssey.	440373-10	440373-10	440373-10	440373-10
15	Arm Mounting Bracket (Lock Side).	202820	202820	202820	202820
16	Rear Barrier	200902	200902	200902	200902
17	Anchor Strap	200906	200906	200906	N/A - Part of Bin
18	Delivery Bin Pad, for Cans or Heavy Products.	660238	660238	660238	660238

123C Golden Eye® Sensor Assembly

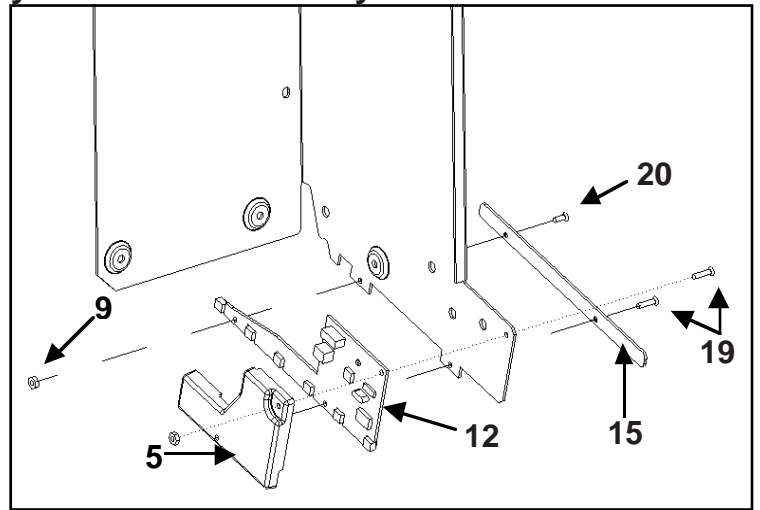
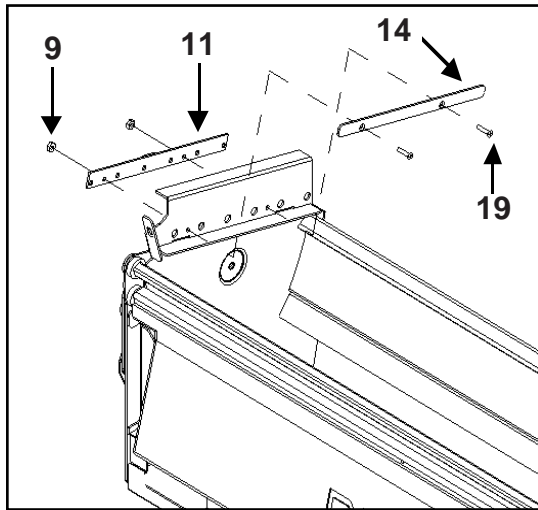

123, 123A & 123B Golden Eye Sensor

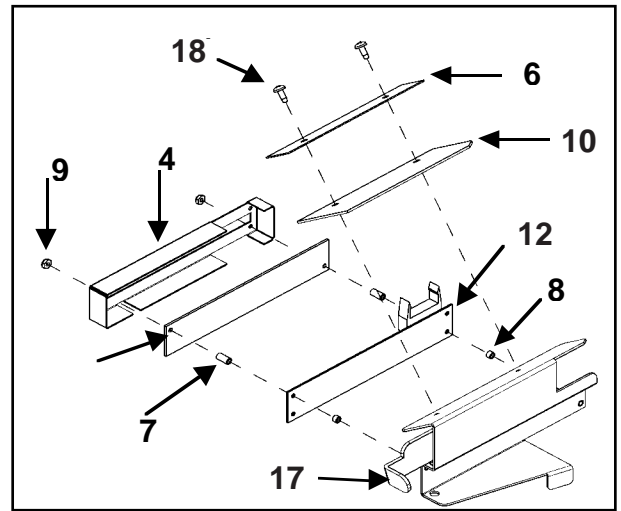
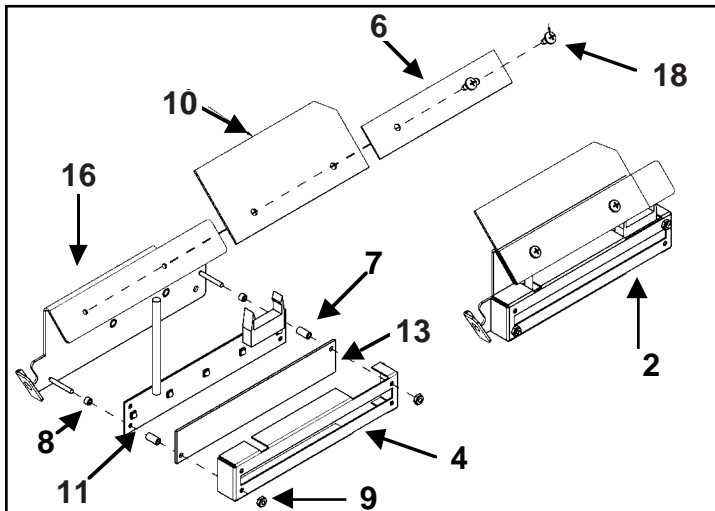

Golden Eye® Bin Sensor Parts		123	123A	123B	123C
1	Golden Eye® (bin sensor) Add On Kit Complete.	17500021	17500021	17500021	17500027
2	Sensor Assembly Complete Hinge Side, Includes	16600218	16600218	16600218	N/A
3	Sensor Assembly Complete Lock Side	16600242	16600242	16600242	N/A
4	Sensor Cover. (Hinge & Lock Side)	12000325	12000325	12000325	N/A
5	Sensor Cover, Lock Side Only.	N/A	N/A	N/A	14400039
6	Side Deflector Bracket. (Hinge & Lock Side)	12000343	12000343	12000343	N/A
7	Stud Spacer 3/16 X .115 X 3/8. (Hinge & Lock Side)	13100016	13100016	13100016	N/A
8	Stud Spacer 3/16 X .115 X 1/8. (Hinge & Lock Side)	13100016-01	13100016-01	13100016-01	N/A
9	Nylon Stop Nut (#4-40). (Hinge & Lock Side)	13100021	13100021	13100021	13100028
10	Deflector Side. (Hinge & Lock Side)	13300012	13300012	13300012	N/A
11	Printed Circuit Board Only, Hinge Side.	13600006	13600006	13600006	13600011
12	Printed Circuit Board Only, Lock Side.	13600006-01	13600006-01	13600006-01	13600010
13	Red Lens (Hinge & Lock Side)	14400029	14400029	14400029	N/A
14	Red Lens, Hinge Side Only.	N/A	N/A	N/A	14400038-01
15	Red Lens, Lock Side Only.	N/A	N/A	N/A	14400038
16	Sensor Bracket Pem Assembly Hinge Side Only.	16400027	16400027	16400027	N/A
17	Sensor Bracket Weldment, Lock Side Only.	16000126	16000126	16000126	N/A
18	Screw (8-32 X 3/8). (Hinge & Lock Side)	276-8R6	276-8R6	276-8R6	N/A
19	Screw, #4 - 40 X 1/2 Flat Head .	N/A	N/A	N/A	13100027
20	Screw, #4 - 40 X 3/8 Flat Head .	N/A	N/A	N/A	13100027-01
21	Harness, Golden Eye® to Control Board. (not shown)	16800096	16800096	16800096	16800100
22	Harness. Sensor Board to Sensor Board. (not shown)	13600007-02	13600007-02	13600007-02	16800101

chill machine supplement

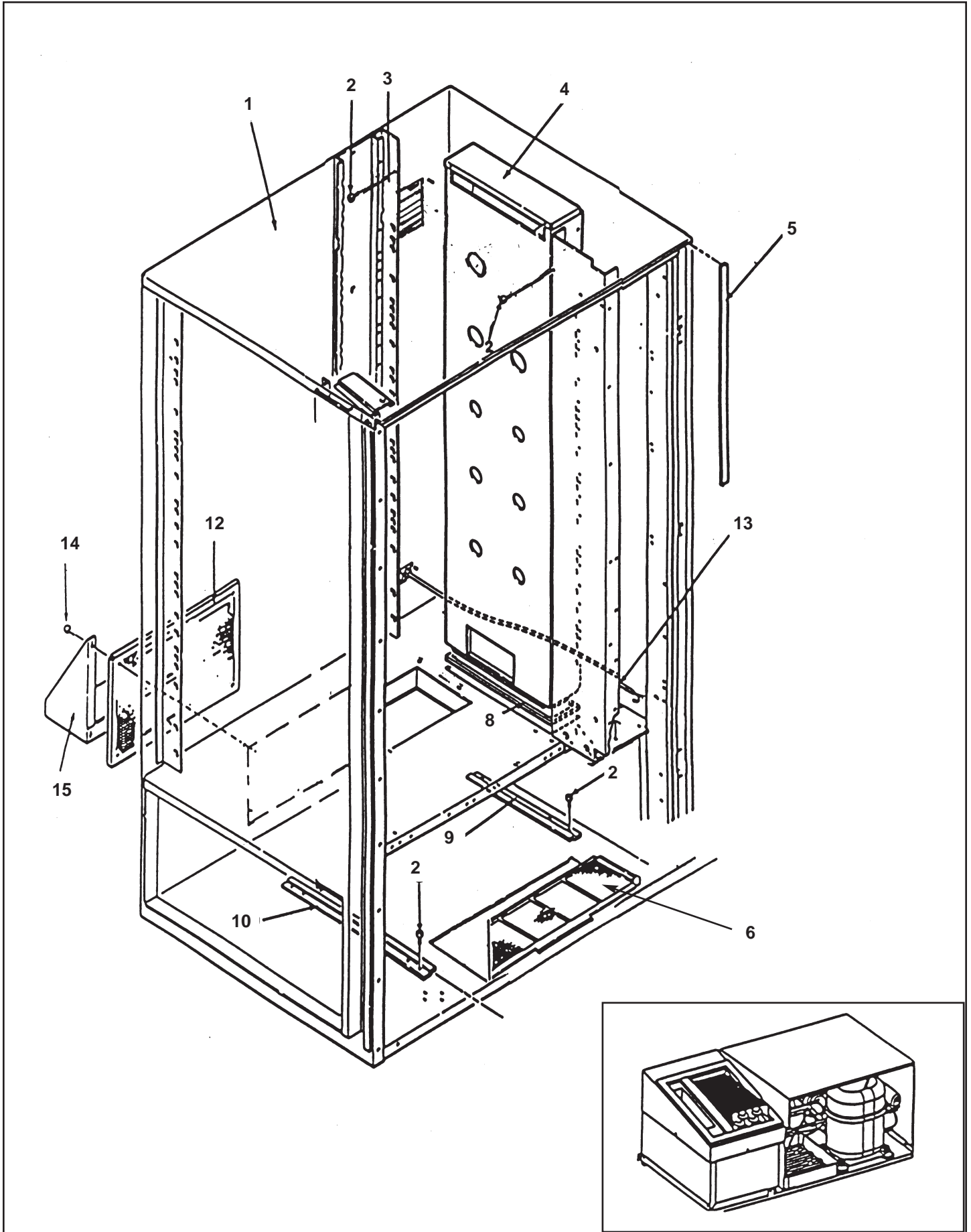

chill machine supplement

Key	Description	123 Below Serial # 12399090000	123A Between Serial #'s 123A99090000 123A01042200	123B Above Serial # 123B01043000	123C Above Serial# 123C02xxxxxx
1	Chilled Cabinet Assembly Complete, with Legs. Specify Color.	N/A	750101-13	750101-13	17500025-07
2	Screw, Pan Head, (8-32 X 3/8)	N/A	276-8R6	276-8R6	276-8R6
4	Air Duct	N/A	12000087	12000087	12000087
5	Door Gasket, Order by Inches.	N/A	460468	460468	460468
6	Front Vent Screen	N/A	12000401	12000401	12000401
8	Door Gasket, Order by Inches.	N/A	460468	460468	460468
9	Right Retainer	N/A	202145	202145	202145
10	Left Retainer	N/A	202144	202144	202144
11	Refrigeration Assembly Complete 117 V, See Page 5.28 for Itemized Parts.	N/A	16600041	16600041	16600041
	Refrigeration Assembly Complete 230 V, See Page 5.28 for Itemized Parts.	N/A	16600041-01	16600041-01	16600041-01
12	Back Vent Screen Assembly.	N/A	16600047	16600047	16600047
13	Power Inlet Cord Only, Domestic.	16800052	16800052	16800052	16800052
	Power Inlet Cord with Plate, Domestic.	16600098	16600098	16600098	16600098
	Power Inlet Cord with Plate, Europe.	16600099	16600099	16600099	16600099
	Power Inlet Cord with Plate, Australia.	16600099-01	16600099-01	16600099-01	16600099-01
	Power Inlet Cord with Plate, Israel	16600099-02	16600099-02	16600099-02	16600099-02
	Power Inlet Cord with Plate, UK.	16600099-03	16600099-03	16600099-03	16600099-03
	Power Inlet Cord with Plate, India.	16600099-04	16600099-04	16600099-04	16600099-04
	Power Inlet Cord with Plate, 120 Volt Export.	16600099-05	16600099-05	16600099-05	16600099-05
14	Screw, Pan Head, (#8-32 X 1/2).	N/A	276-8R8	276-8R8	276-8R8
15	Air Deflector	N/A	202842	202842	202842
	Bin Close off Plate (not shown).	N/A	12000003	12000003	12000003

Insulation - Chilled Machine					
	Right Rear.	N/A	12200001	12200001	12200001
	Right Shelf Support.	N/A	12200002	12200002	12200002
	Back Left.	N/A	12200004	12200004	12200004
	Shelf Rear.	N/A	12200008	12200008	12200008
	Back.	N/A	12200009	12200009	12200009
	Pivot Side.	N/A	12200010	12200010	12200010
	Left Shelf Support.	N/A	12200012	12200012	12200012
	Foam Insulation, Shelf.	N/A	12200017	12200017	12200017
	Foam Insulation, Front.	N/A	12200024	12200024	12200024
	Foam Insulation, Rear.	N/A	12200025	12200025	12200025
	Shelf Front.	N/A	12200030	12200030	12200030
	Foam Insulation, Rear Shelf Front, Pivot Side.	N/A	12200032	12200032	12200032
	Top.	N/A	12200034	12200034	12200034
	Lock Side.	N/A	12200035	12200035	12200035
	Top Lock Side Insulation, Shelf.	N/A	12200036	12200036	12200036
	Insulation Back.	N/A	12200037	12200037	12200037
	Insulation Cabinet top.	N/A	12200038	12200038	12200038
	Insulation, Top Front.	N/A	12200039	12200039	12200039
	Insulation Pivot Side Chanel Top 1/2".	N/A	420385-1	420385-1	420385-1
	Insulation Pivot side Chanel Front 3/4".	N/A	420386-1	420386-1	420386-1

chill machine supplement

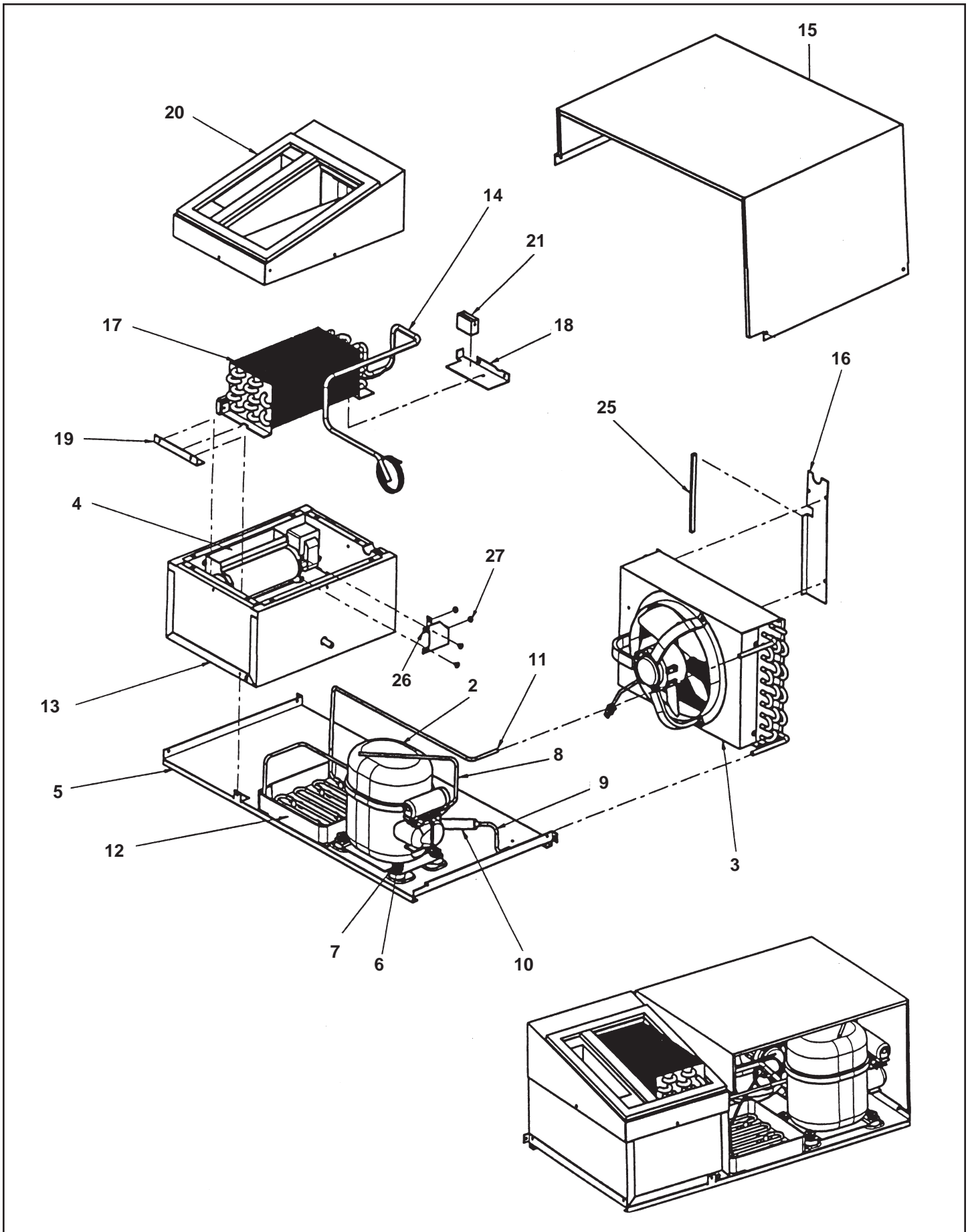

Key	Description	117V, 60 Hz Domestic	230V, 50 Hz Export	220V, 60 Hz Brazil
	Chiller Assembly Complete	16600041	16600041-01	16600198
1	#8 x 3/8 Screw (All Screws)	210-8R6	210-8R6	210-8R6
2	Compressor Complete w/Start Components	360270	360271	16700004
2A	Compressor Only	360270-1	360271-1	16700004-01
2B	Start Capacitor	360270-2	360271-2	16700004-08
2C	Capacitor End Cap	360270-5	360271-3	16700004-09
2D	Thermal Overload Switch	360270-8	360271-8	16700004-04
2E	Start Relay	360270-11	360271-11	16700004-10
2F	Compressor Foot	360270-4	360271-4	16700004-05
3G	Electrical Cover	360270-14	360270-14	360270-14
3H	Clip, Electrical Cover	360270-9	360270-9	360270-9
3	Condenser Coil Complete w/Fan and Motor	660720	660720-1	660720-1
3A	Condenser Coil Only	420422	420422	420422
3B	Condenser Fan with Housing	360269	360269-1	360269-1
3C	Condenser Shroud	202879	202879	202879
4	Evaporator Fan Motor	16700017	16700017-01	16700017-01
5	Refrigeration Mounting Plate	12000063	12000063	12000063
6	Compressor Mounting Plate	300225	300225	300225
7	Compressor Mounting Clip	420426	420426	420426
8	Tube, Process	12100001	12100001-01	121000007
9	Tube Condenser Outlet	420428	420428	420428
10	Drier	420427	420427	420427
11	Tube, Compressor Discharge	12100001	12100001-01	121000007
12	Evaporator Pan	440459	440459	440459
13	Evaporator Housing	16400002	16400002	16400002
14	Capillary/Suction Line	12100004	12100004	121000020
15	Cover, Condensing Unit	12000065	12000065	12000065
16	Bracket Condensing Unit Cover	12000064	12000064	12000064
17	Evaporator Coil Assembly	16600062	16600062	16600062
18	Evaporator Bracket Rear	12000070	12000070	12000070
19	Evaporator Bracket Front	12000071	12000071	12000071
20	Evaporator Housing, Top Assembly	16600040	16600040	16600040
21	Evaporator Air Block	13300005	13300005	13300005
25	Gasket, 1/4 x 5/16	13000001	13000001	13000001
26	Evaporator Motor Bracket	202893	202893	202893
27	Hex Nut, 8-32	404-08	404-08	404-08
28	Harness, Compressor (not shown)	16800028	16800028	16800058

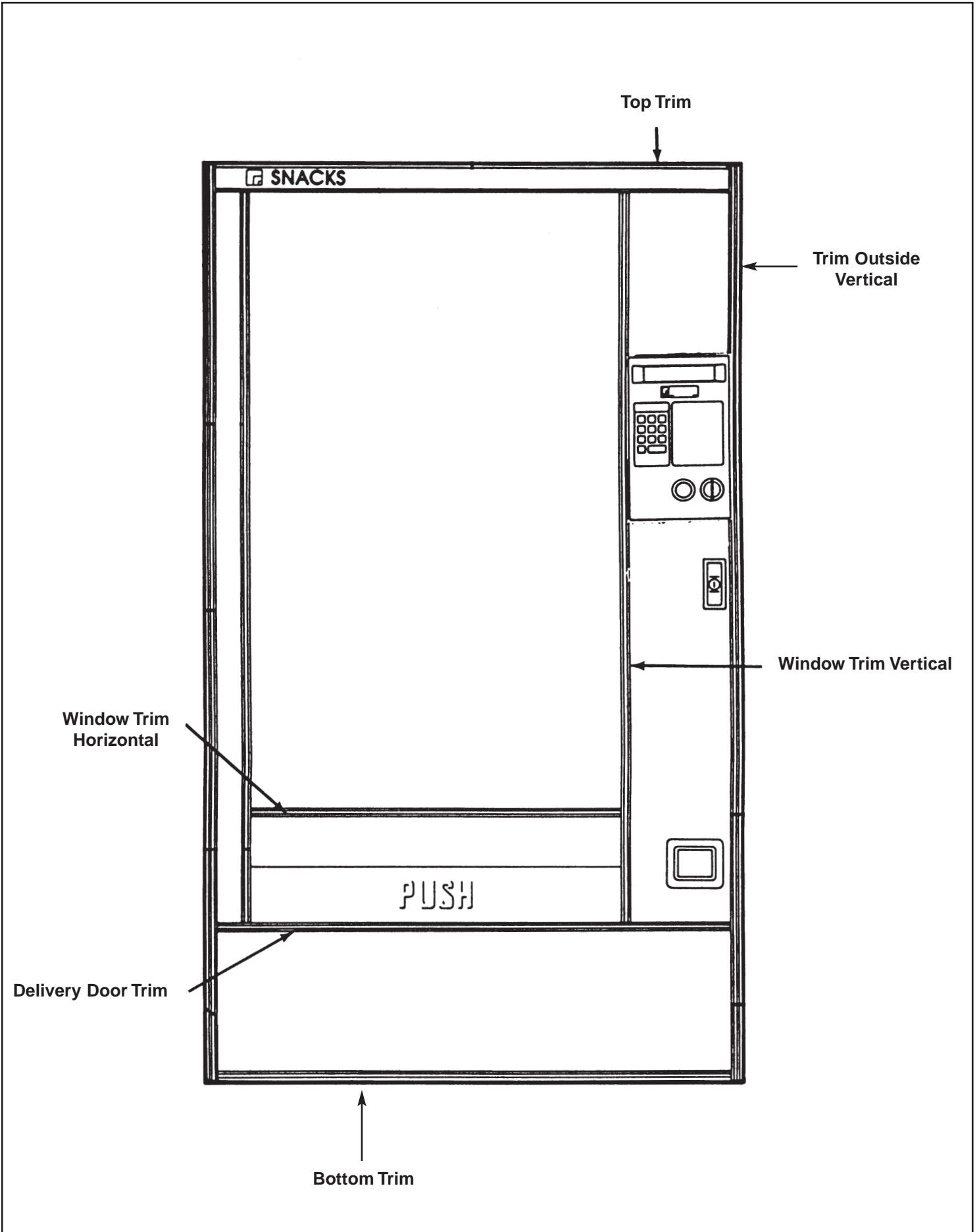

123 Trim		VIP	AP II	Vantage	Aramark	Award	CP3	Sterling, Mission	Tron	Genesis	Apollo	Euro - Grey	Euro - Black	
		Part #												Dimensions
Top Trim	Part #													
Silver, use with insert	340042-8	1				1				1				2 3/4 x 36.890
Black	340055-9								1					Length 36.890
Black, use with insert	340042-10							1						2 3/4 x 36.890
	340044-9			1										
Silver, use with insert	340044-4				1									1.798 x 36.890
Silver w Black tape	660231-3						2							Length 36.890
Silver, use with insert	340044-11										1	1	1	1.798 x 26.997
Trim Outside Vertical	Part #													Length
Silver	340057	2				2	2			2				65 39/64
Black	340057-2			2				2	2					65 39/64
Silver Taped	660231-20				2									65 39/64
Window Trim Horizontal	Part #													Length
Silver	340058	1			1	1	1		1					26.721
Black	340058-5			1				1		1				26.721
Black	340062-3										1		1	26.997
Clear	340062-2											1		26.697
	340058-46													
Window Trim Vertical	Part #													Length
Silver	340058-7	2				2								51.531
Silver	340058-2				2									52.468
Silver	340058-4						2							50.937
Black	340058-6							2		2				51.531
Black	340058-8								2					50.937
	340058-46			2										
Silver	340062										2	2		65.406
Black	340062-1												2	65.406
Delivery Door Trim	Part #													Length
Silver	340055-3				1	1								36.89
Black	340055-9							1		1				36.89
Silver w Black tape	660231-3	1					1							36.89
Black	340062-3										1		1	26.997
Clear	340062-2											1		26.997
	340058-5			1										
Bottom Trim	Part #													Length
Silver w Black tape	660231-3	1					1		1					36.89
Black, Square	340055-9													36.89
Door Vinyl Edge Trim	201678-5										1	1	1	27 3/16
Door Vinyl Edge Trim	201678-2				1	1		1		1				37 57/64
Door Vinyl Edge Trim	201678			1										

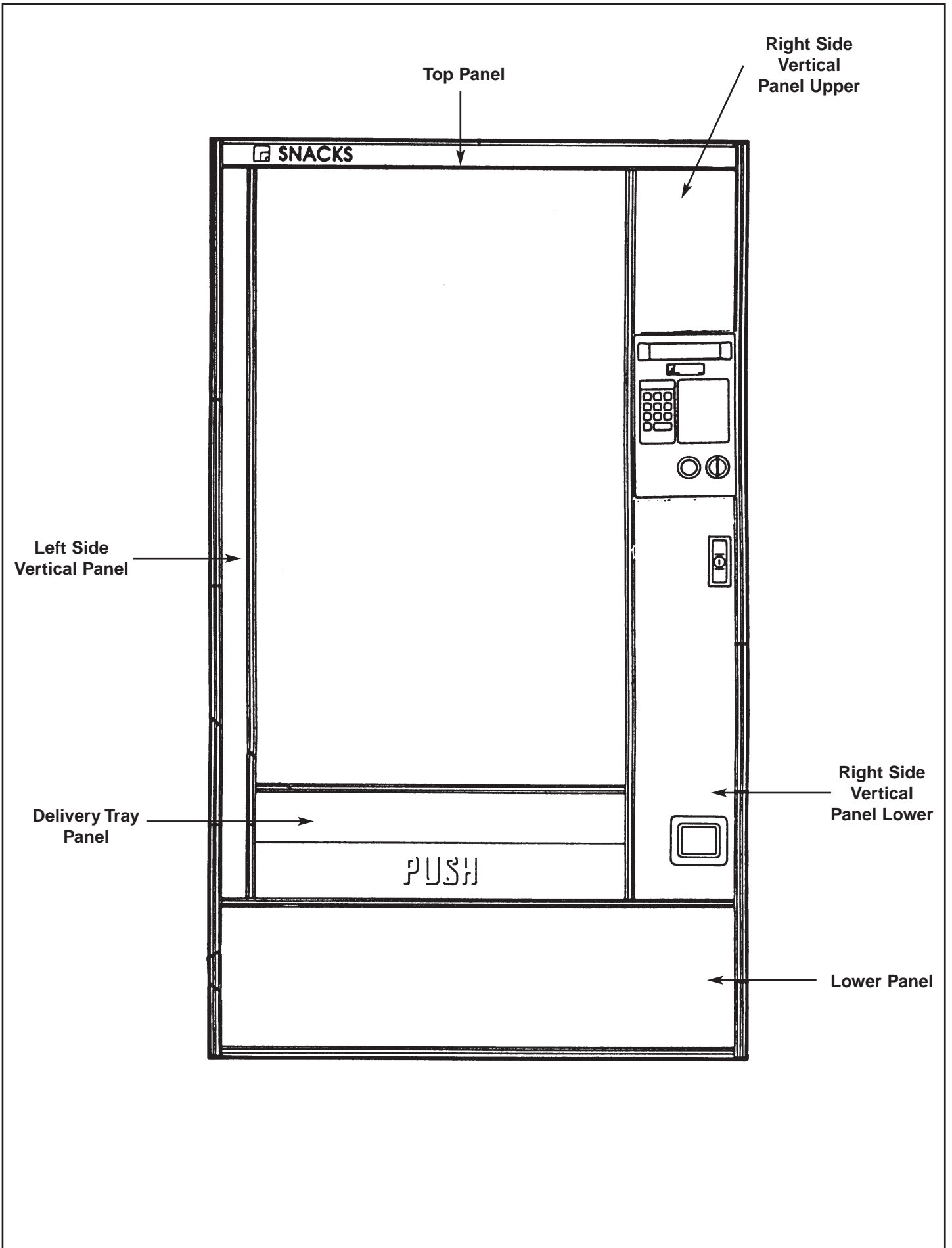

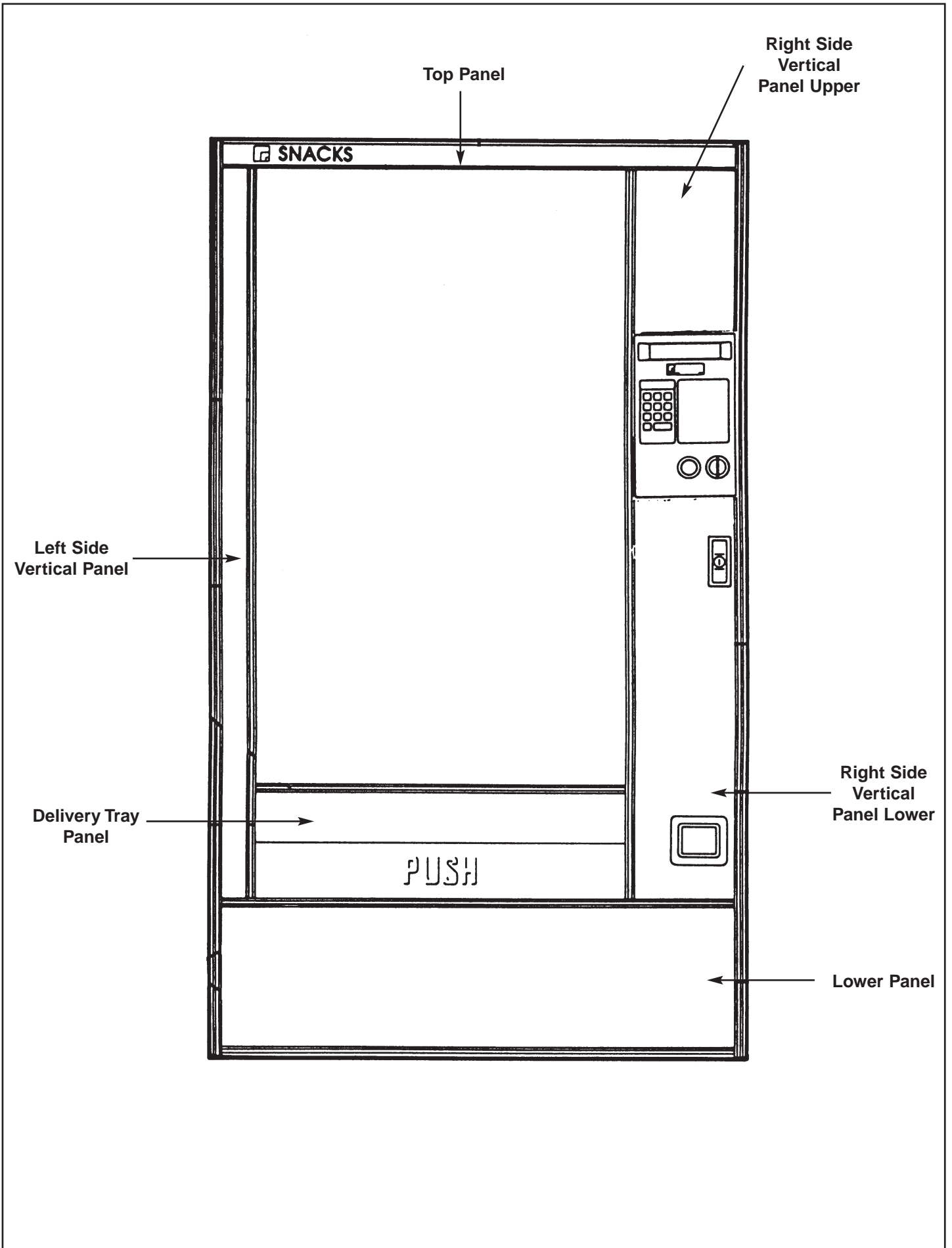

123 PANELS

123 PANELS		VIP, Pres Wal	VIP, Black Hide	Vantage, Dove Grey	Vantage, Sterling Royce	CP3, Pres Wal	CP3, Black Hide Plain	CP3, Black Pika	CP3, Black Pika, Sterling	CP3, Slate	CP3, Dove Grey	CP3, Port Au Prince, Pres Wal	Sterling/Mis Bsn Blk, Mor Gry	Sterling/Mis, Slate Pewter	Sterling, Bison Black, Mission	Tron, Dove Grey	Tron, Black Pika	Tron, Slate	Tron, Black Hide Plain	Tron, Sterling Royce	Genesis, Slate	Genesis, Black Hide, Stripe	Genesis, Black Hide, No Stripe	Genesis, Black Pika, all black	Aramark, Dove Grey	Aramark, Pika	Aramark, Slate	Aramark, Pres Wal	Aramark, Black Hide	Aramark, Sterling Royce	Aramark, Trendline Grey	Apollo	Euro Black	Euro Grey	Dimensions					
Left Side Vertical Panel	Part #																																					Dimensions		
Presidential Walnut	202059	x																																				2.031 x 53.875		
Presidential Walnut	202059-4					x																																2.031 x 51.218		
Black Hide	202059-42		x			x													x			x	x							x							2.031 x 53.875			
Sterling Royce Van	202059-52				x																																	2.031 x 65.578		
Sterling Royce	202059-54							x													x																	2.031 x 51.218		
Black Pika	202059-61						x										x							x			x											2.031 x 53.875		
Slate	202059-58								x									x				x							x										2.031 x 53.875	
Dove Grey	202059-50			x																																			2.031 x 65.578	
Port Au Prince	202059-5											x																											2.031 x 51.218	
Dove Grey	202059-45																																						2.031 x 53.875	
Dove Grey	202059-16									x							x																						2.031 x 51.218	
Pewter Sterling	202059-7													x																									2.031 x 53.875	
Sterling Royce	202059-9																																			x			2.031 x 53.875	
Bisson Black	202059-63														x																								2.031 x 53.875	
Trendline Grey	202059-14																																			x			2.031 x 53.875	
Morocco Grey	202059-56												x																										2.031 x 53.875	
Right Side Vert. Panel, Lower	Part #																																						Dimensions	
Presidential Walnut	202805-3	x																																					7.563 x 26.641	
Presidential Walnut	202805-5					x																																	7.563 x 26.641	
Black Hide	202805-7		x			x													x			x	x															7.563 x 26.641		
Sterling Royce	202805-9				x																																		7.563 x 37.898	
Sterling Royce	202805-45							x													x																		7.563 x 26.641	
Black Pika	202805-25						x											x						x															7.563 x 26.641	
Slate	202805-29								x										x				x																7.563 x 26.641	
Trendline Grey	202805-51																																						7.563 x 26.641	
Dove Grey	202805-17																																							7.563 x 26.641
Dove Grey	202805-43			x																																				7.563 x 37.898
Port Au Prince	202805-11												x																											7.563 x 26.641
Dove Grey	202805-31									x																														7.563 x 26.641
Pewter Sterling	202805-23																																							7.563 x 26.641
Trendline Grey	202585-51																																							7.563 x 26.641
Dove Grey	202805-19																																							7.563 x 26.641
Bisson Black	202805-35																																							7.563 x 26.641
Morocco Grey	202805-21																																							7.563 x 26.641
Right Side Vert. Panel, Upper	Part #																																							Dimensions
Presidential Walnut	202806-7	x																																						7.563 x 15.234
Presidential Walnut	202806-9						x																																	7.563 x 12.578
Black Hide	202806-11		x			x														x			x	x															7.563 x 15.234	
Sterling Royce	202806-13				x																																			7.563 x 15.234
Sterling Royce	202806-45							x																																7.563 x 12.578
Sterling Royce	202806-47																																							7.563 x 15.234
Black Pika	202806-29						x																																	7.563 x 15.234
Slate	202806-33								x																															7.563 x 15.234
Dove Grey	202806-21																																							7.563 x 15.234
Dove Grey	202806-23																																							7.563 x 12.578
Dove Grey	202806-55			x																																				7.563 x 15.234
Port Au Prince	202806-15																																							7.563 x 12.578
Dove Grey	202806-35																																							7.563 x 12.578
Pewter Sterling	202806-27																																							7.563 x 15.234
Morocco Grey	202806-25																																							7.563 x 15.234
Bisson Black	202806-49																																							7.563 x 15.234
Trendline Grey	202806-63																																							7.563 x 15.234

123 odyssey trim & panels

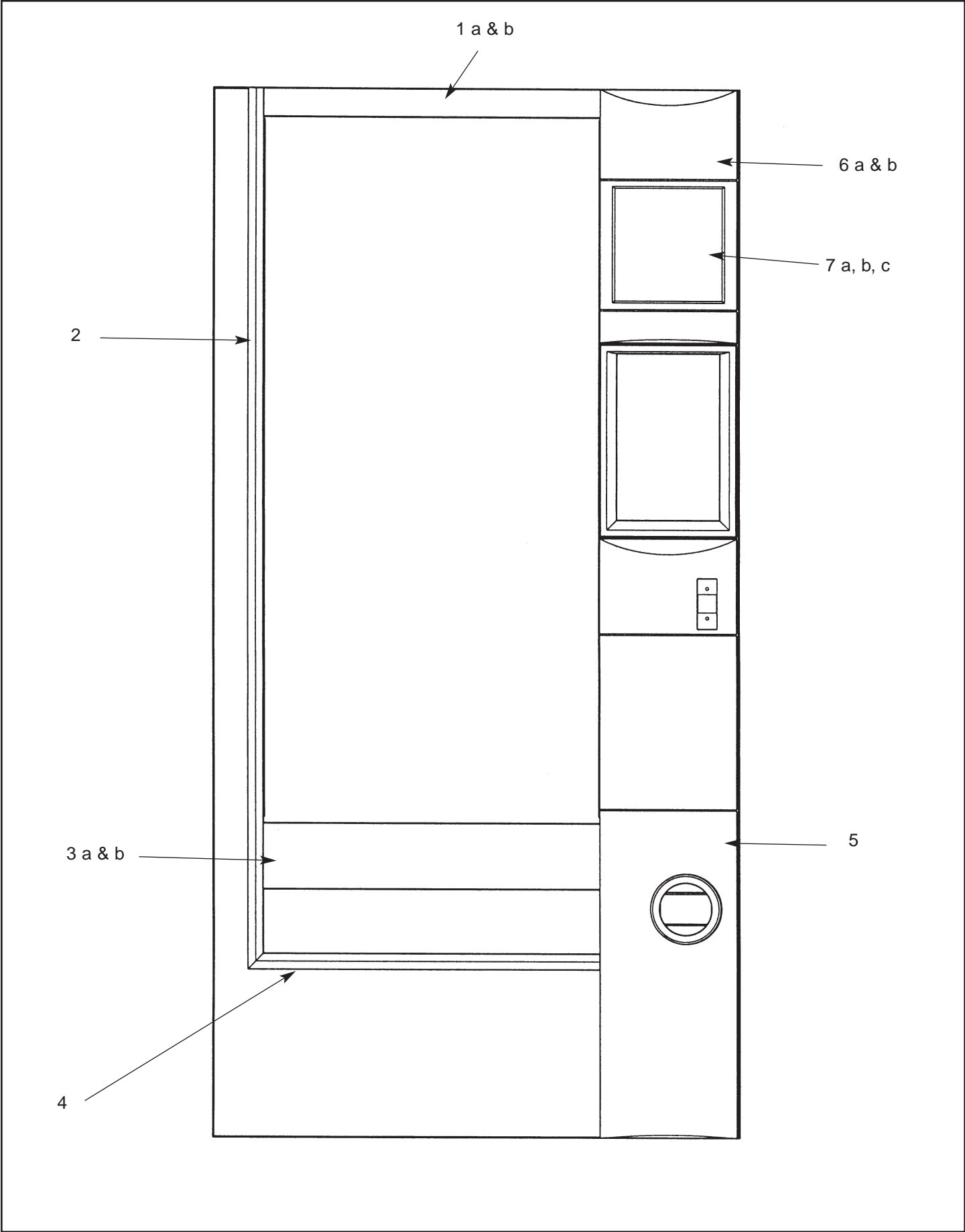

Item No.	Part No.	Description
1a	13400001	Top Trim
1b	16400010	Retainer, Top Trim (3 required)
2	38647	Vertical Trim
3a	13400002	Delivery Bin, Trim
3b	16400011	Retainer, Bin Trim (3 required)
4	14400009	Trim, Under Delivery Door.
5	38342	Lower Right Side Column.
6a	16600111	Upper Column W POS, Assembly.
6b	38355	Column Only W POS Cut Out
6c	38356	Upper Column, No POS Cut out
7a	38497	Viewer Window
7b	38498	Adapter, POS Window
7c	38499	Back Panel, POS Window

Item No.	Part No.	Description

connectors



PUSH MOUNT CABLE TIE
380291

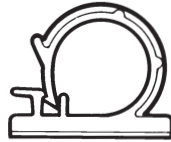

CABLE CLAMP ADHESIVE
3/4 - 420096
1/2 - 420096-1



WIRE CLAMP
420051

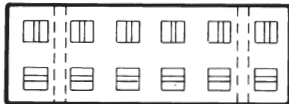

PLUG - 12 PIN
380289

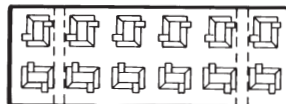

SOCKET - 12 PIN
380290



MOLEX CRIMP TERMINAL
380234

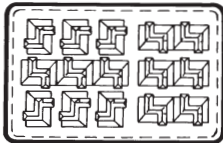

SOCKET 15 CIRCUIT
380276



MOUNTING TYPE
CABLE TIE
380078



2 PIN INTERNATIONAL MOLEX
380281



2 PIN INTERNATIONAL MOLEX
RECEPTACLE
380280



4 PIN INTERNATIONAL MOLEX PLUG
380296
3 PIN INTERNATIONAL MOLEX PLUG
FREE HANGING - 380286
PANEL MOUNT - 380286-1

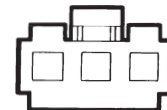

4 PIN INTERNATIONAL MOLEX
RECEPTICAL - 380293
3 PIN INTERNATIONAL MOLEX
RECEPTICAL - 380288

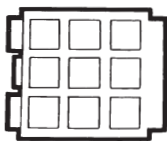

9 PIN INTERNATIONAL MOLEX
PLUG
380282

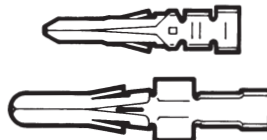

MALE MOLEX TERMINAL
SMALL .093 - 380005
LARGE .062 - 380130

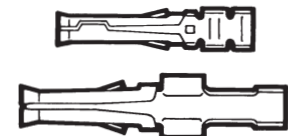

FEMALE MOLEX TERMINAL
SMALL .093 - 380004
LARGE .062 - 380129

trouble shooting chart

Problem	Symptom	Remedy
No Power	No Lights	Check Wall Outlet and Line Cord. Check for 120vac Where Line Cord Plugs into Power Box. Check On/off Switch.
	Lights Work No Power out to Logic Board.	Check 8vac and 24vac Breaker on Junction Box
	No Led on Logic Board	Check for 8vac and 24vac at J5 Connector Coming onto Logic Board.
Doesn't Accept Coin	No Power to Changer	Check for 8vac and 24vac at J5 Connector Coming onto Logic Board.
	Changer Unplugged	Plug in Changer
	Defective Changer	Replace Changer
	Defective Logic Board	Replace Logic Board
	Only Accepts one Coin	Machine Lost Vend Prices, Reprice and Test.
Won't Payout Change, Incorrect Change Returned	Changer Unplugged	Plug in Changer
	Defective Changer	Replace Changer
	No Power to Coin Payouts	Replace Logic Board.
	Coins Jammed in Tubes	Remove Coins
Use Correct Change	Coin Tubes Empty	Fill Coin Tubes
	Coin Tube Inventory Not Programed Correctly	Check Coin Tube Inventory.
	Defective Coin Tube Sensor.	Replace Coin Changer
Coin Mechanism Jackpots	Incorrect Voltage	Check Voltages \pm 10%
	Defective Coin Mechanism	Replace Coin Mechanism
	Defective Logic Board	Replace Logic Board
Won't Take Bills	No Coins in Coin Tubes	Fill Coin Tubes
	Belts or Stacker Don't Run on Power Up.	Check for 24vac at Validator.
	Belt Run, Bill Goes in Half Way but Won't Accept	Replace Validator.
	Incorrect Coin Tube Inventory	Check Inventory of Coin Tubes by Pressing F7.

trouble shooting chart

Problem	Symptom	Remedy
Display Says Make Another Selection.	Motor Half Cycled	Open and Close 120 Cabinet Door to Home Motor.
	Motor Not Turned on in Configuration	Turn on Motor in Configure Motors Menu Item Then Open and Close 120 Cabinet Door and Machine Will Scan and Turn on That Selection.
	Motor Won't Turn	Press F6 to See If Motor Works in Test Vend, If it Does Check Motor Configuration, If Not Change Motor.
Multiple Motors Running Together.	Motor Wire or Cabinet Back Harness Shorted.	Check for Shorted Motor Wire or Cabinet Back Harness.
	Defective Logic Board	Replace Logic Board
Unable to Enter Mastermenu (Service Mode)	Bad Interlock Switch	Check Interlock Switch
	Defective Changer	Replace Changer
	Defective Logic Board	Replace Logic Board
Motor Doesn't Home on Door Clousure.	No Voltage	Check for Voltages
	Defective Door Switch	Replace Door Switch
	Defective Logic Board	Replace Locic Board.
No Lights	No Power to Lights	Check for 120 Vac out of Junction Box
	Defective Ballast	Replace Ballast, Loose Harness
	Defective Starter	Replace Starter

Troubleshooting for Golden Eye®

- 1) Verify that supply voltage at P11 of LCB is correct – Pin 5 (-) & 7(+) = 8 to 10 VDC
- 2) Check power/data harness at connection to Golden Eye® board, on bottom of swing panel.
- 3) Check ribbon cable at both ends to ensure proper orientation and connection. Make sure ribbon cable has not been crimped or damaged
- 4) Observe LED on bottom of swing panel, with door closed

NORMAL OPERATION

No credit established.

LED is on in standby condition – this indicates that Golden Eye® is in standby and the Beams are not obstructed.

Pin 1 to Pin 2 – P11 should measure 0 Vdc.

GOLDEN EYE® IS BLOCKED

LED is off

Obstruction blocking beams

Pin 1 to Pin 2 – P11 should measure -5 Vdc

Determine cause of obstruction, Potential causes are:

Gum & Mint deflector on left side of G & M shelf blocking beams

Sliver reflector at bottom of door glass interfering with beam

Temporarily remove obstruction to verify cause.

After removing obstruction, power machine off, then on, to reset Golden Eye® circuit.

DURING A VEND

LED is on in standby, will blink as product falls through beams.

Once vend motor starts, Pin 1 to Pin 2 – P11 should measure +5 Vdc.

When product falls through beam, voltage will temporarily drop to 0 Vdc, then return to +5 Vdc

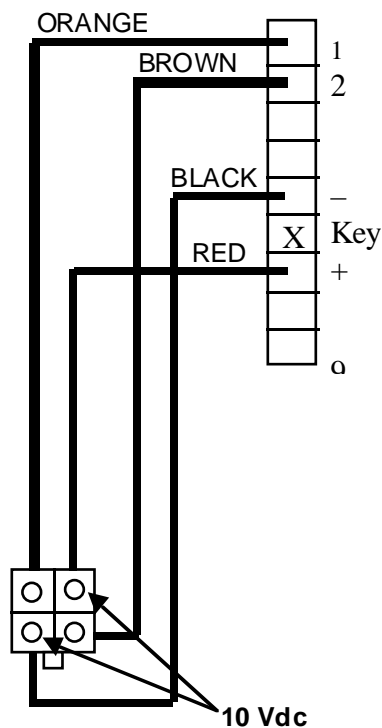

MasterMenu Keypad pinouts

PINS	4	8	11	5	2	12	1	13
6	1	2	3	F1	F5	F6	ESC	+
7	4	5	6	F3	F7	*	--	<
10	7	8	9	F2	.25	1.00	INS	>
9	0	C/CE		F4	.05	.10	DEL	ENT

MasterMenu Plug Orientation

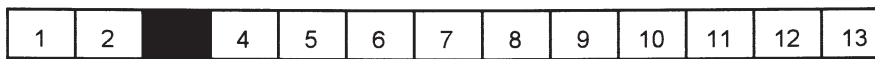

DIRECTIONS FOR INSTALLING SOFTWARE UPGRADE IN APi120

- 1) Turn off power to the Control Module and the Food Cabinet. Wait 5 minutes for the large capacitor to discharge before working on the board. Identify and separate the three chips before beginning any work. The two chips for the Control Module are identified as LCB VX.XX.
- 2) Remove all connectors and covers from the control board.
- 3) Remove the battery from the LogiCenter Board (LCB), and observing proper anti-static procedures (grounded wrist strap) remove the two socketed chips, and replace. Refer to the drawing at right for the correct orientation of each chip.
- 4) Replace the board cover, and reinstall all harnesses. Before restoring power to machines, make sure that the Service Connector and Power Connector are plugged to the board correctly.

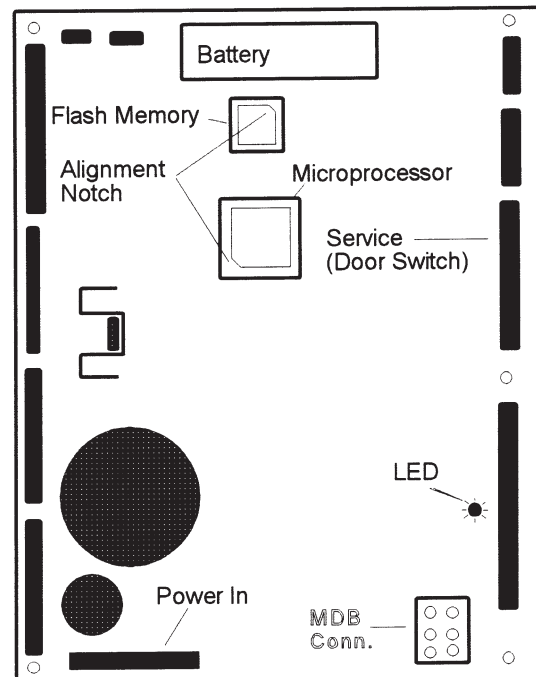

Control Board Installation Instructions

(For Lcb part's 360251 & 360274)

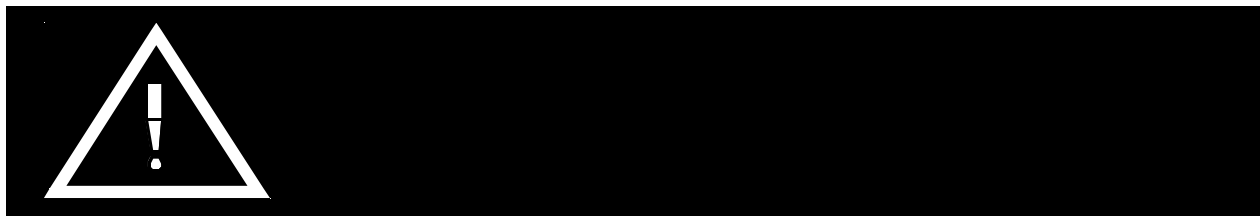

When installing this board into any machine it is necessary that the board be reset to factory defaults.

Instructions to reset the board are as follows:

Install the board into the machine and reconnect all the harnesses and power up the machine.

1. Open Machine/Tower door.
The display should say Enter for MasterMenu.
2. Press Enter.
3. Press the > until the display indicates Security.
4. Press Enter
5. The display will indicate Machine ID, press the < one time and the display will indicate Machine Reset - N.
6. Press the + key the display will indicate Machine Reset machine - Y.
7. Press the Enter key, The display will indicate Reset - Messages.
8. Press the + key until the display indicates Reset - All.
9. Press Enter, the key and the display will indicate Are you Sure - N.
10. Press the + key and the display will indicate Are you Sure - Y.
11. Press the Enter key and board will beep and the display will default to Machine Reset - N.
The Board has now been set to factory default.
12. See quick set up reference page in the Service Manual for Instructions on programming the Control Board.
13. Open and close door on the 120 to scan selections.

electrical connections



P12 DISPLAY
 1 5 VDC
 2 RXD/TO
 3 GND

P13 BATTERY
 1 VBAT
 2 GND
 3 KEY
 4 GROUND

P11 COFFEE/Golden Eye
 1 DATA OUT
 2 DATA IN
 3 CLOCK
 4 LOAD/STROBE
 5 GROUND
 6 KEY
 7 8 VDC
 8 34 VDC
 9 GROUND

P7 KEYPAD SWITCH LINES
 1 1
 2 2
 3 KEY
 4 4 See table
 5 5 Selector Switch
 6 6 Drawing
 7 7 On Previous Page.
 8 8
 9 9
 10 10
 11 11
 12 12
 13 13

P10 EXECUTIVE
 1 RCV +
 2 RCV -
 3 XMIT -
 4 GND
 5 XMIT +
 6 24Vac
 7 KEY
 8 24Vac

P9 VALIDATOR
 1 ESCROW ENABLE HIGH
 2 \$1 ENABLE HIGH
 3 \$2 ENABLE HIGH
 4 \$5 ENABLE HIGH
 5 ESCROW ENABLE LOW
 6 \$1 ENABLE LOW
 7 \$2 ENABLE LOW
 8 \$5 ENABLE LOW
 9 CREDIT
 10 KEY
 11 GND
 12 24Vac HOT
 13 24Vac NFUTRAI

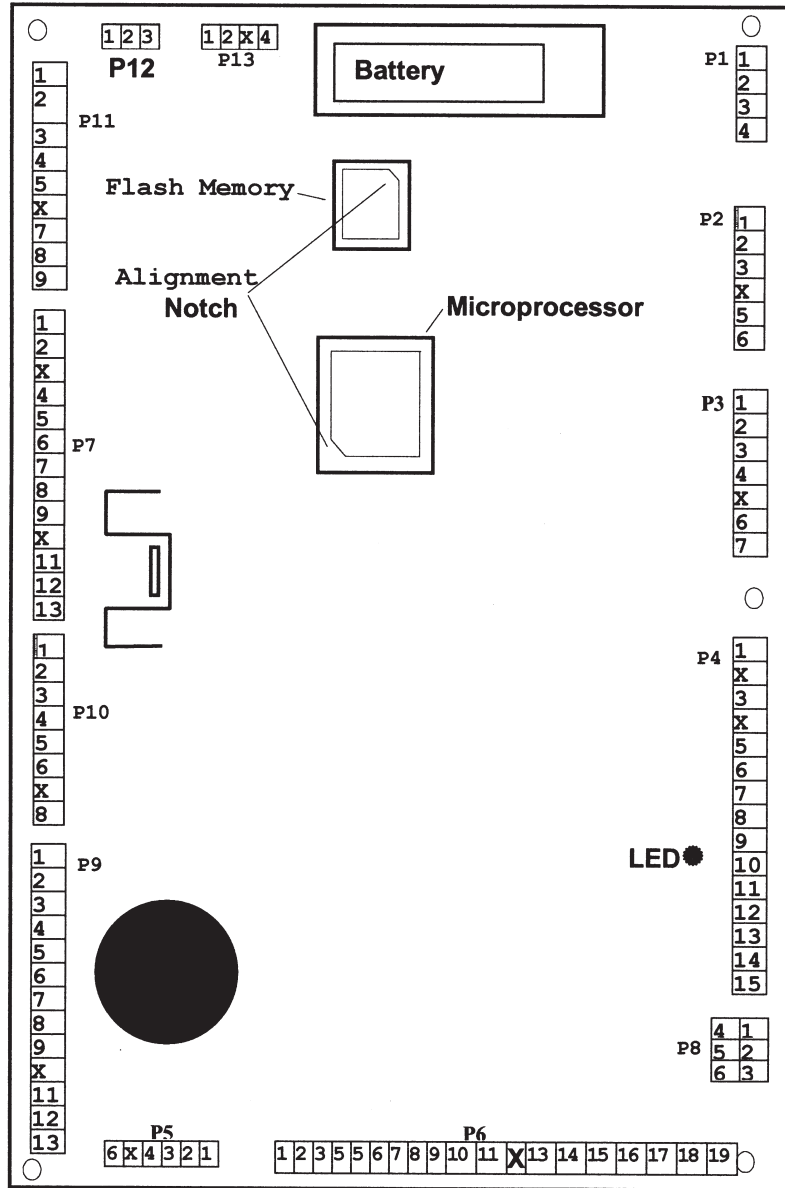

P1 MEMORY UNIT
 1 DATA
 2 NO CONNECTION
 3 KEY
 4 GND

P2 RS232 SERIAL INTERFACE
 1 RECEIVE DATA
 2 GND
 3 TRANSMIT DATA
 4 KEY
 5 -10 VOLTS
 6 +5 VOLTS

P3 SERVICE
 1 34 VDC
 2 WINNER RELAY
 3 LOCKOUT
 4 GND
 5 KEY
 6 DOOR SW
 7 GND

P4 MC5010
 1 -24 VNFDC RET
 2 KEY
 3 +24 VNFDC HOT
 4 KEY
 5 DATA
 6 INTERRUPT
 7 ACCEPT ENABLE
 8 RESET
 9 SEND
 10 5VDC
 11 GND
 12 .05
 13 .10
 14 .25
 15 \$1.00

P8 MDB +
 1 34 VDC
 2 PWR GND
 3 8 VDC
 4 MASTER RXD
 5 MASTER TXD
 6 COMMUNICATION COMMON

P5 POWER
 1 24Vac
 2 24Vac
 3 8Vac
 4 8Vac
 5 KEY
 6 EARTH GROUND

P6 DC MOTOR DRIVE
 1 ROW 1 +
 2 ROW 2 +
 3 ROW 3 +
 4 ROW 4 +
 5 ROW 5 +
 6 ROW 6 +
 7 ROW 7 +
 8 ROW 8 +
 9 COL 0 -
 10 COL 1 -
 11 COL 2 -
 12 KEY
 13 COL 3 -
 14 COL 4 -
 15 COL 5 -
 16 COL 6 -
 17 COL 7 -
 18 COL 8 -
 19 COL 9 -

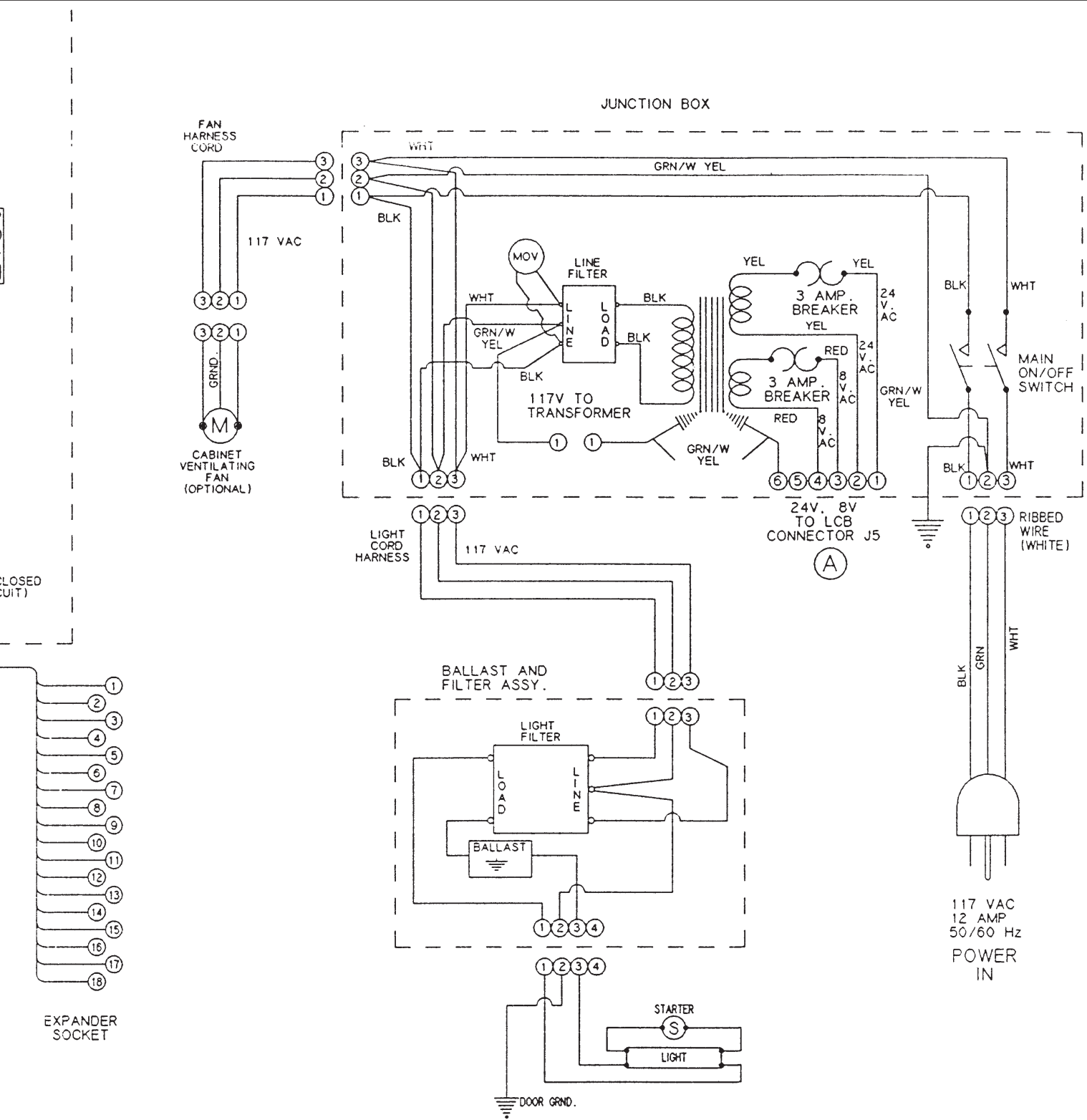

AUTOMATIC PRODUCTS
INCORPORATED

121, 122, 123
 VENDING MACHINES

48015803
 4-6-01

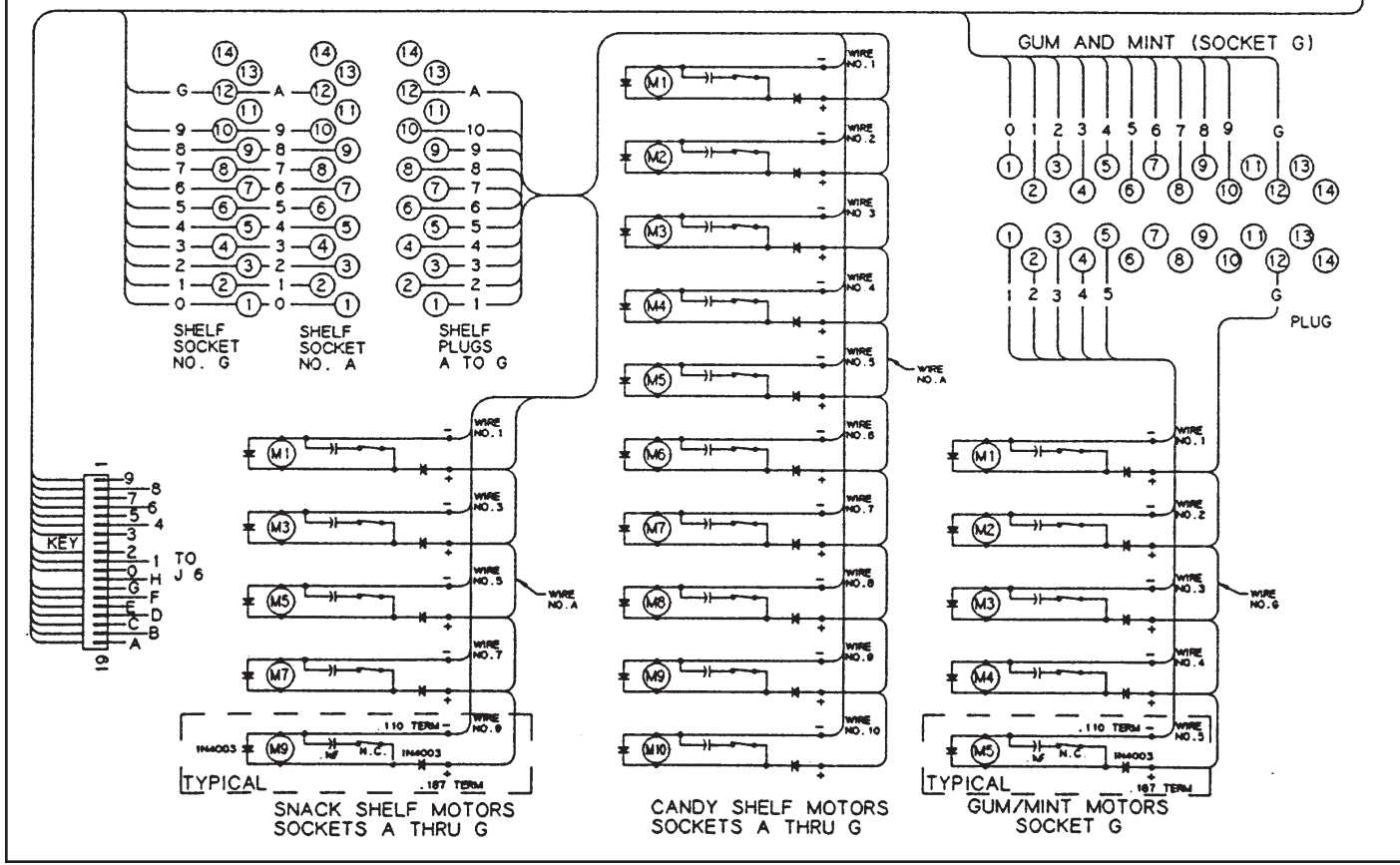
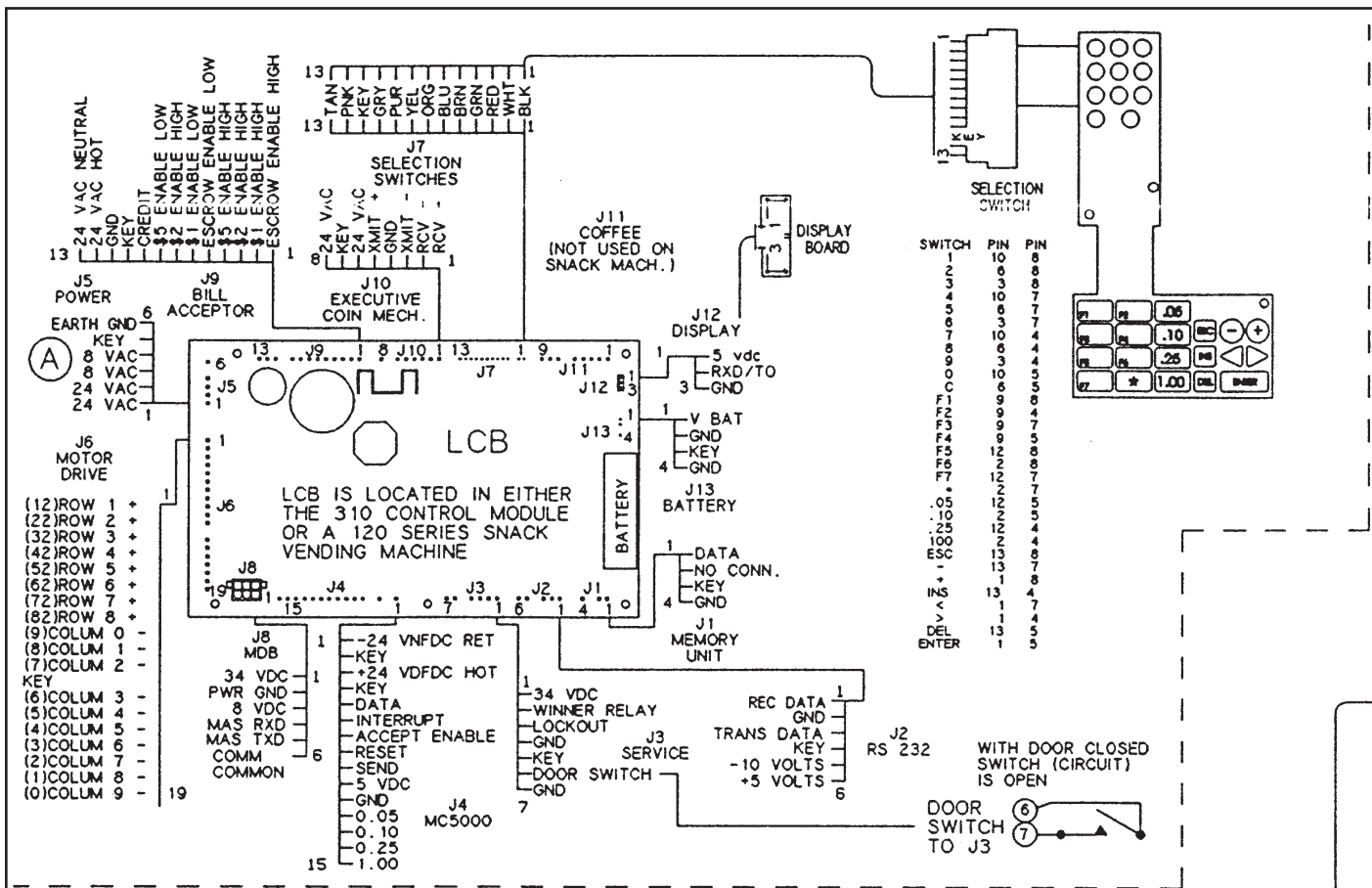

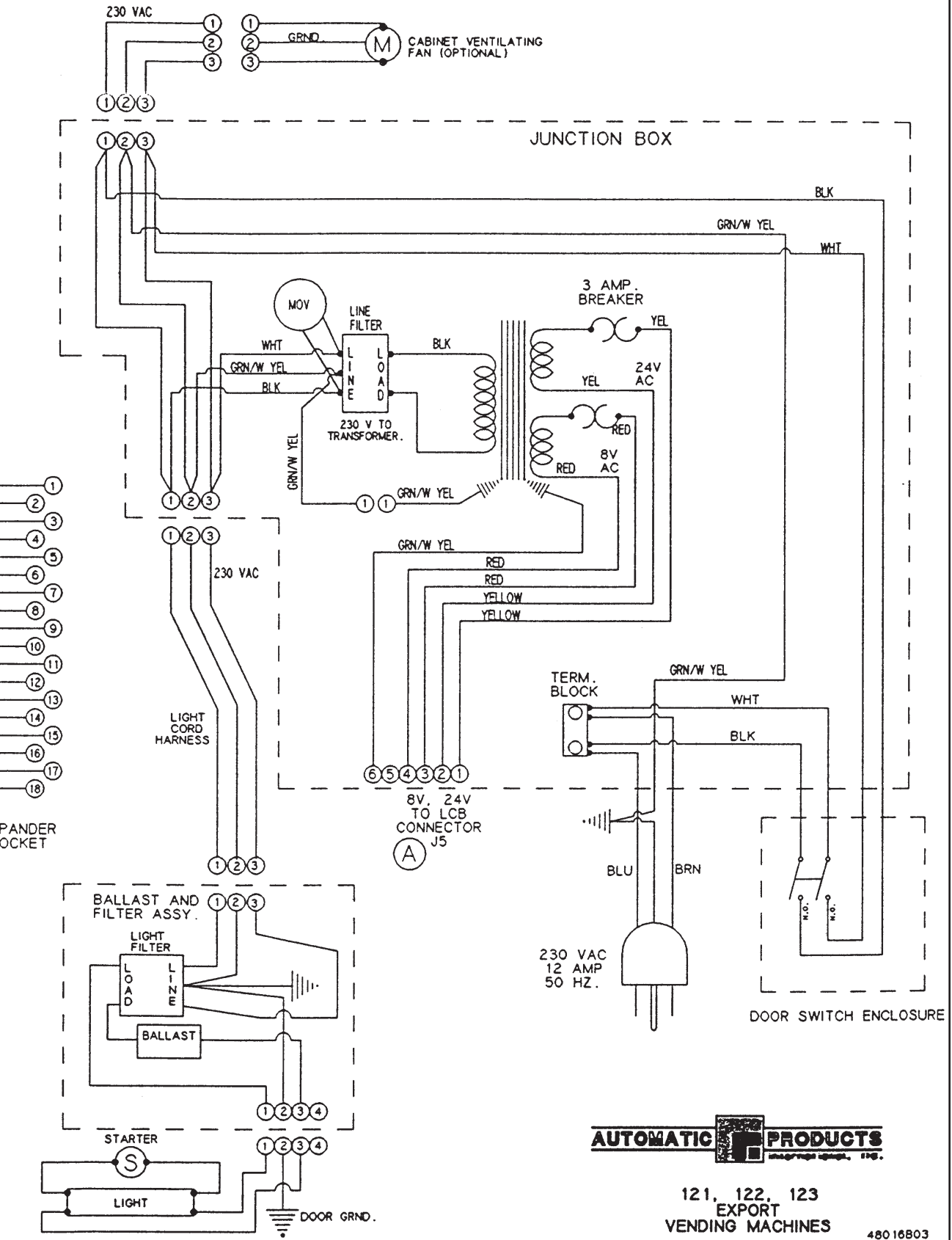

AUTOMATIC PRODUCTS
Manufactured in U.S.A.

121, 122, 123
 EXPORT
 VENDING MACHINES

48016803
 4/8/01

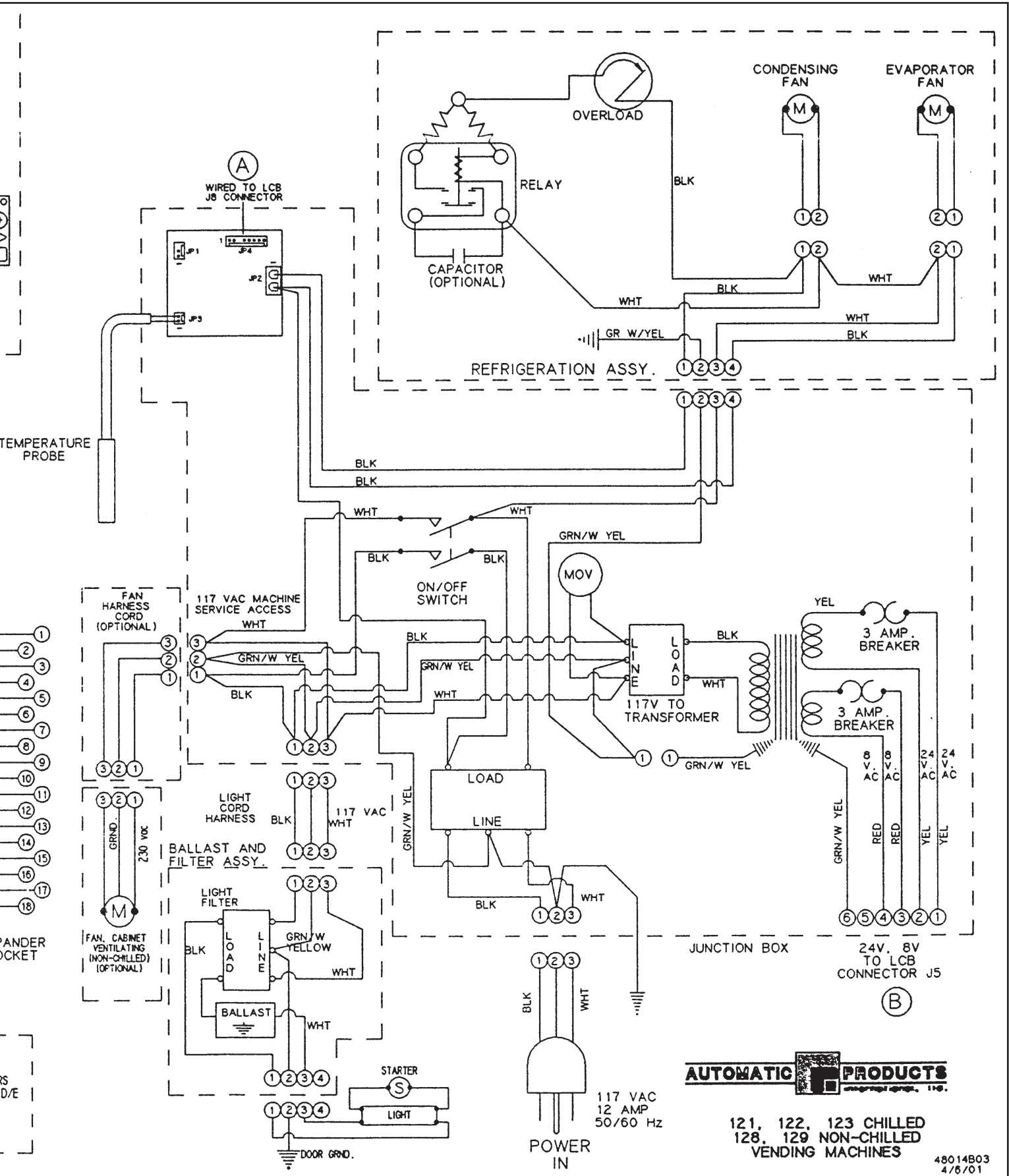

AUTOMATIC PRODUCTS
Manufactured in U.S.A.

121, 122, 123 CHILLED
 128, 129 NON-CHILLED
 VENDING MACHINES

48014803
 4/6/01

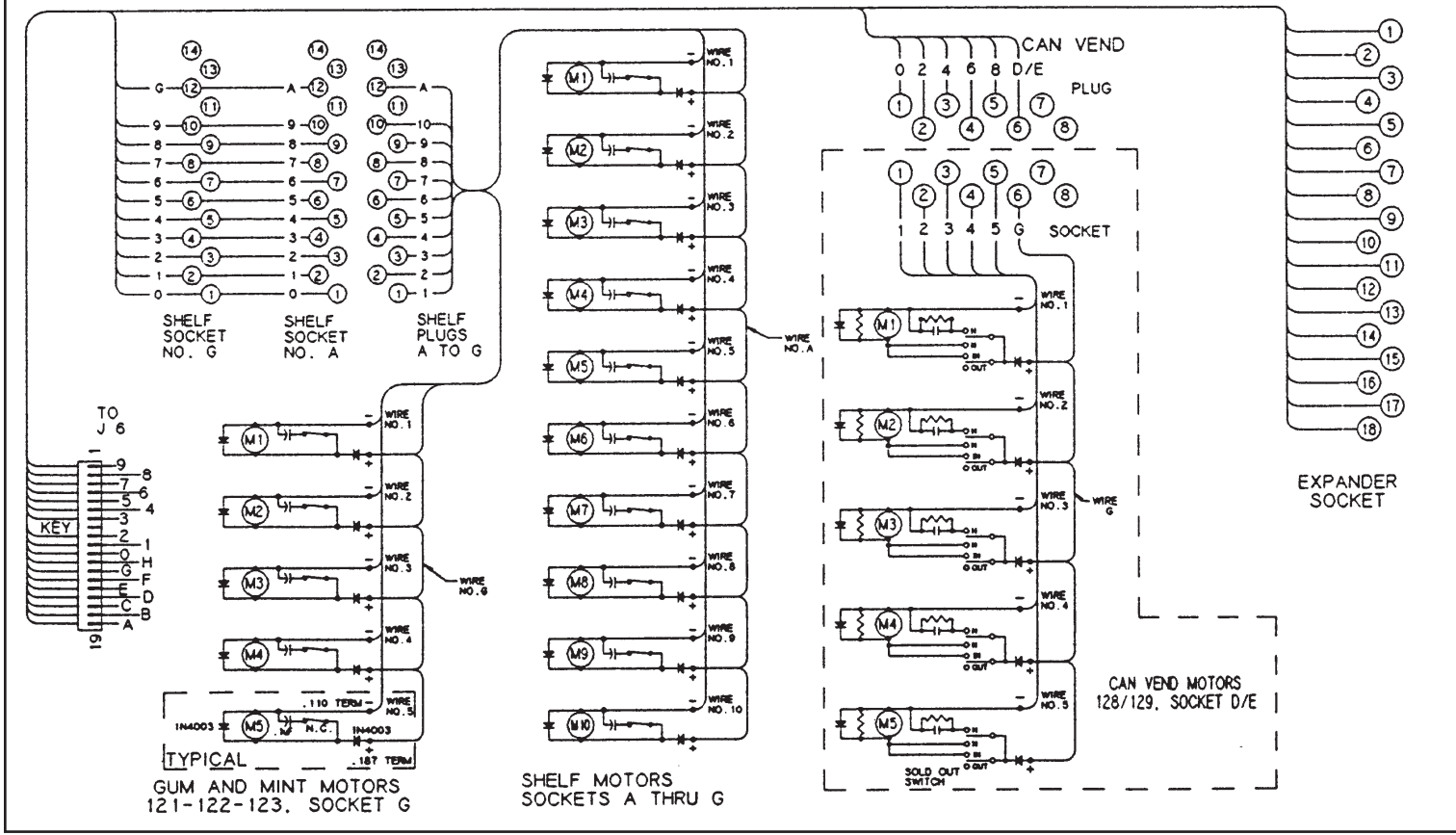
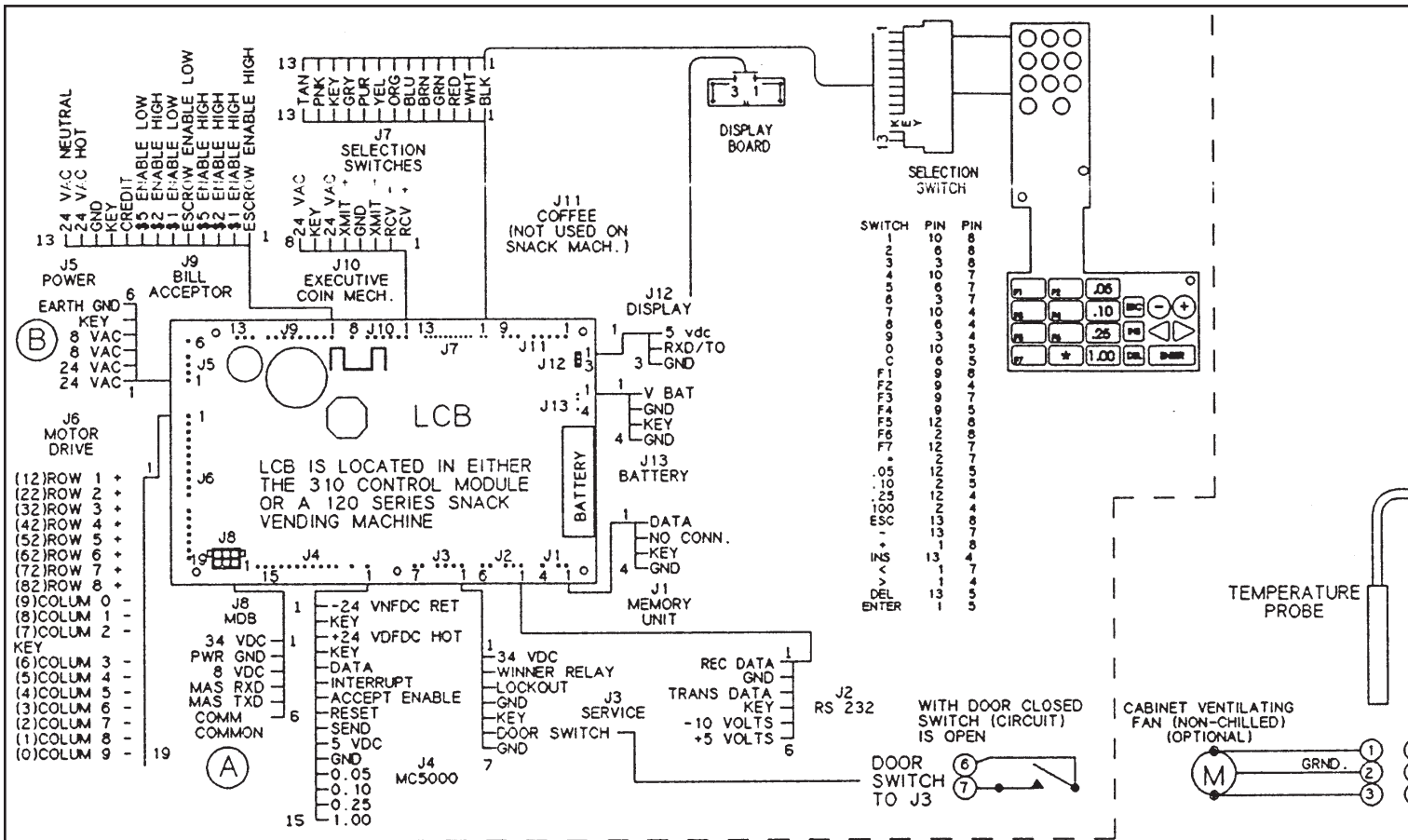

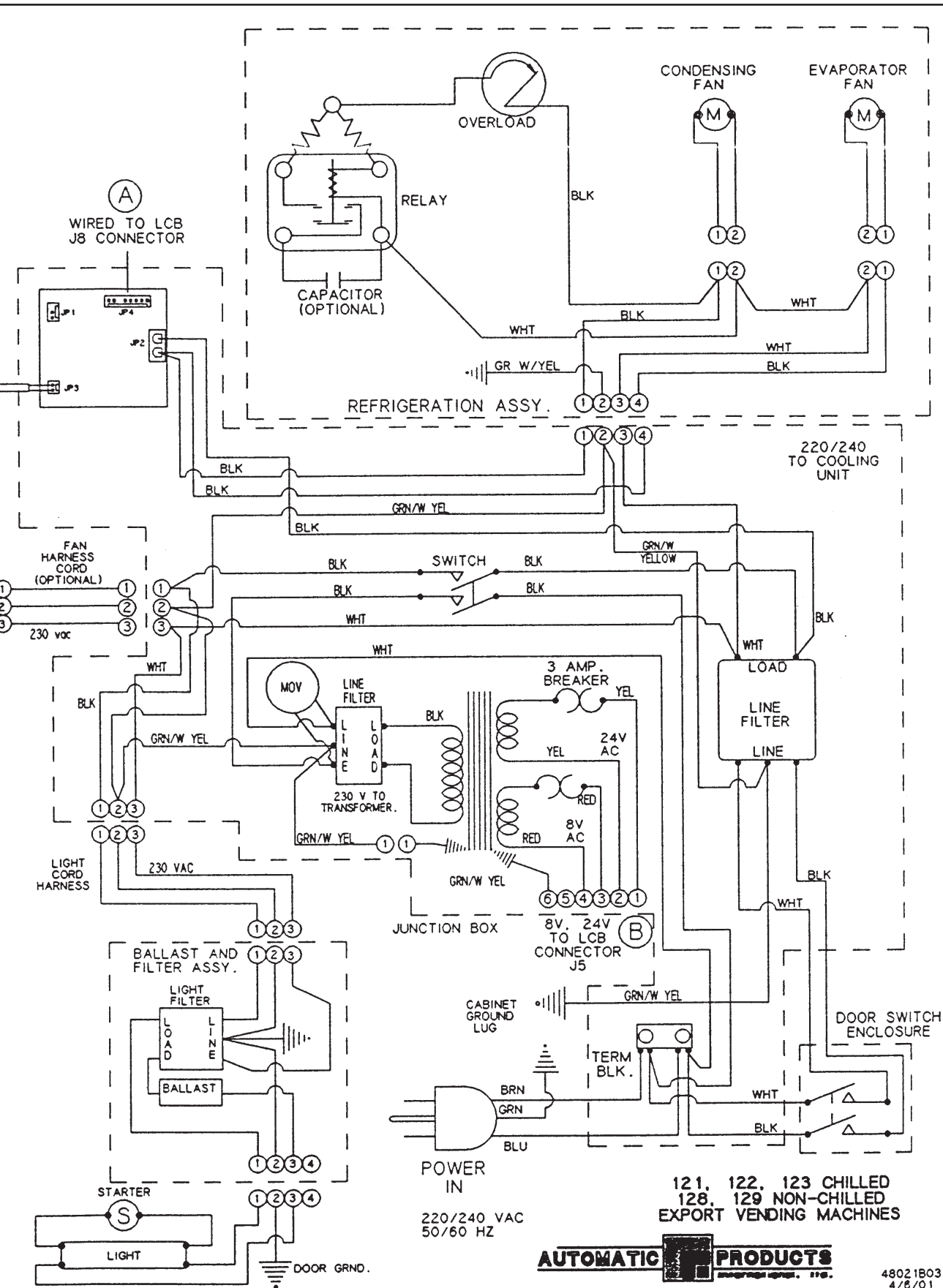

AUTOMATIC PRODUCTS

48021803
4/8/01